



CLADDING BOARD AND PANEL APPLICATIONS



CONTENTS

About the panel	3	Panel cladding	12
Features and benefits	4	screw fixing	12
Properties	6	fixing distances	14
Boarding	8	corner details	15
horizontal	8	ventilation and joints	16
vertical/diagonal	9	Other exterior applications	17
grooved panels	10	Coatings	18
ventilation and joints	10	More information	20
fasteners and placing	11		
fixing distance	11		



MEDITE TRICOYA EXTREME

These guidelines have been written in collaboration with industry experts for professionals wishing to use MEDITE® TRICOYA® EXTREME to create beautiful, reliable and highly durable end products.

Should you require further information or have any queries or comments about MEDITE TRICOYA EXTREME (MTX) or this document, please contact MEDITE through:

www.mdfosb.com

ABOUT MEDITE

MEDITE is one of Europe's most recognised brands of MDF. First launched in 1976, we were pioneers in introducing MDF to European markets. This has allowed MEDITE products to now be recognised as the benchmark for quality, consistency and performance throughout the MDF market. MTX is yet another pioneering advancement in wood panels.

ABOUT THE PANEL

MTX is a completely new, innovative form of wood panel product. It demonstrates outstanding durability and stability in the most extreme and challenging environments – both exterior as well as interior wet applications.

The product uses proprietary acetylation wood technology and a modified fibre board manufacturing process to create a wood panel product with outstanding durability and stability.

MTX was developed by challenging the most fundamental reason for wood swelling and decay: water adsorption onto hygroscopic wood fibres due to the presence of hydroxyl groups. The hydroxyl groups (water loving sites) can bind or release water molecules causing wood to swell or shrink.

Acetylation is a non-toxic, sustainable process which increases the number of naturally occurring hydrophobic acetyl groups in the wood cells using acetic anhydride. The process exchanges the hydroxyl groups (chemical formula: $-OH$) with acetyl groups (chemical formula: $-COCH_3$) preventing water at these sites, and thus, enhancing the dimensional stability and durability of the wood.

Apart from creating an exceptional dimensional stability, the process enables MTX to achieve Class 1 Durability, leading to resistance to biological decay which exceeds oak.

MTX offers a solution for specifiers and consumers in environments of wet, high humidity or fully weather exposed applications to deliver superior performance in versatile large panel form.

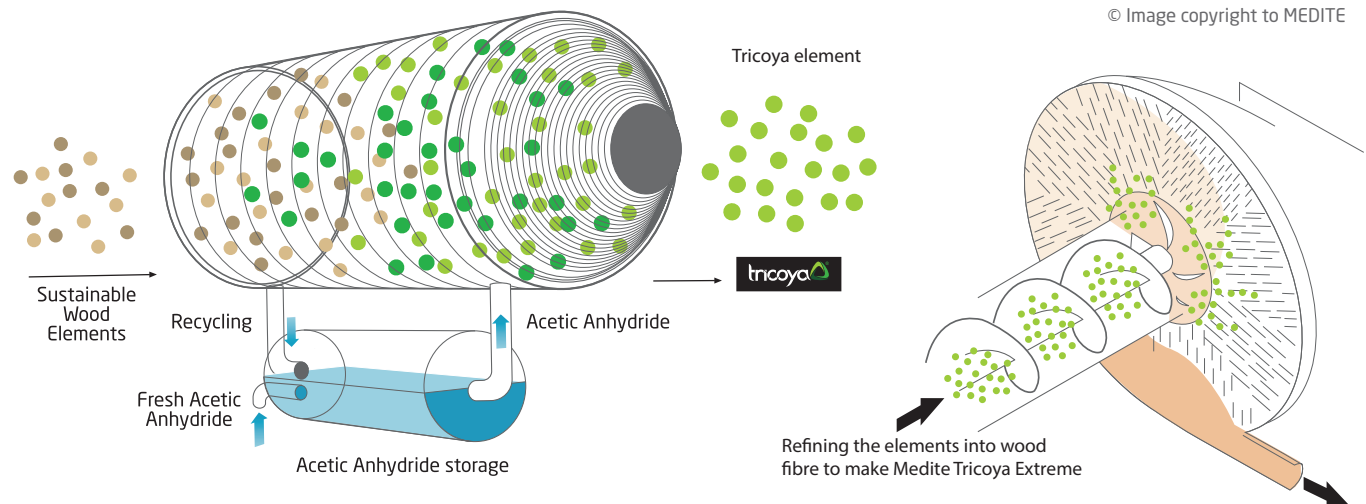



FEATURES & BENEFITS



DURABLE

Longer lasting, perfect for external and internal wet environments



50 YEAR GUARANTEE

Peace of mind with a 25 year in-ground and 50 year above ground guarantee



ENHANCED STABILITY

Swelling and shrinking dramatically reduced



DESIGN FREEDOM

All the design, fixing and machining flexibility of MDF



SUSTAINABLY SOURCED

FSC® certified. Wood used from sustainable sources



LOWER MAINTENANCE COST

Extended periods between exterior coatings maintenance



PERFECT FOR COATING

Improved stability and durability enhances service life of the coating. Damaged coating will not affect the core



RESISTANT TO FUNGAL DECAY

Effective barrier to fungal decay



DESIRED SERVICE LIFE OF 60 YEARS

Independent testing by BRE shows an expected service life of 60 years for exterior use

PROPERTIES

MEDITE TRICOYA EXTREME (MTX) is a new class of durable wood panel product with enhanced dimensionally stability, suitable for a wide range of exterior applications such as cladding, façade panelling, fascias, soffits, etc. MTX can be cut, machined and installed using techniques and equipment commonly used throughout the building industry and require very low maintenance thereafter. The flexibility of MTX offers endless design opportunities so that it can be cut to size, machined, painted, wrapped etc. without impacting on its unique properties.

Moisture content

MTX moisture content should be below 10% before processing and coating applications.

UKCA and CE marking

All MEDITE products supplied for use in the construction and civil engineering industries are CE marked according to the requirements of the harmonized European standard for wood-based panels EN 13986. This provides the necessary assurance to customers and users that MTX conforms to the European standard, EN622-5 and meets all the essential requirements for the Construction Products Regulation (CPR) that are relevant to the product. MTX is also UKCA (UK Conformity Assessed) marked.



Reports and certificates

The Fraunhofer Institute for Wood Research (WKL) concluded that the performance of MTX is so outstanding that it will allow a wood based panel to be used in applications that have not previously been possible.

Building Research Establishment (BRE) performance testing indicated that MTX achieves durability class 1 under EN350-2.

SP Wood Technology tested the product's ability to resist wood destroying basidiomycetes (white and brown rot) with outstanding results.

British Board of Agrément (BBA) assessment concludes that MTX is suitable for internal and external non-structural applications.

PROPERTY	RANGE	TEST METHOD	UNITS	THICKNESS					
				4	6	9	12	15	18
Density	+/- 30	-	kg/m ³	720	720	720	720	700	680
Internal Bond	Min	EN 319	N/mm ²	0.8	0.8	0.8	0.8	0.8	0.8
Modulus of Rupture	Min	EN 310	N/mm ²	30	30	30	25	20	20
Modulus of Elasticity	Min	EN 310	N/mm ²	3000	3000	3000	2500	2500	2500
Screw holding (Face)	Min	EN 320	N	-	-	-	-	900	900
Screw holding (Edge)	Min	EN 320	N	-	-	-	-	700	700
Thickness swell (24 hrs)	Max	EN 317	%	2.5	2.5	2.0	2.0	1.5	1.5
Internal bond after boil test	Min	EN 319	N/mm ²	0.65	0.65	0.65	0.65	0.65	0.65
Thermal conductivity	-	EN 12664/67	W/mK	0.101					
Reaction to Fire	-	EN 13501-1	Class	E					
Free Formaldehyde	Max	EN 120	mg/100g		< 1.0	< 1.0	< 1.0	< 1.0	< 1.0
Dimensional tolerance	Length / Width	EN 324-1	mm/m	+/- 1.0					
	Thickness	EN 324-1	mm	+/- 0.15					
Dimensional change per 1% change in moisture content	Length / Width	EN 318	%	+/- 0.1					
	Thickness	EN 318	%	+/- 1.0					
Coefficient of thermal expansion	-	NPL	mm/m°C	0.0137					
Dimensional movement per 10% RH change	-	NPL	mm/m	0.25					

THE RESULTS LISTED ABOVE ARE BASED ON THE MINIMUM SPECIFICATION REQUIREMENTS FOR MEDITE TRICOYA EXTREME MANUFACTURED BY MEDITE EUROPE DAC. ALL PARAMETERS ARE IN COMPLIANCE WITH EN 622 PARTS 1 & 5. AS PART OF THE MEDITE EUROPE ONGOING PRODUCT DEVELOPMENT PROGRAMME, THE RIGHT TO MODIFY THESE PRODUCT SPECIFICATIONS WITHOUT NOTICE IS RESERVED. MEDITE TRICOYA EXTREME CONTAINS NO ADDED FORMALDEHYDE AND THE FORMALDEHYDE CONTENT IS LESS THAN 1.0 MG/100 G USING EN 120 TEST METHOD, WHICH IS FAR BELOW THE LOWER LEVELS REQUIRED BY CARB PHASE 2.

BOARDING

If using MEDITE TRICOYA EXTREME (MTX) in a system which resembles a wooden cladding system there are a number of jointing techniques to be considered depending on the final appearance of the façade.

Traditionally normal wood type cladding measures 150 mm wide, with a recommended limit of 190 mm due to cupping issues. The width of MTX boards is not restricted by cupping and can therefore be wider, leading to a strong visual appeal unobtainable with traditional wood.

MTX is suitable for standard cladding types, and in general, the installer should follow the same recommendations for fitting as with traditional wood boarding, requiring no special detailing or tools. As with traditional wood boarding, a ventilated cavity needs to be present behind the boards.

MTX panels can be cut, profiled, embossed or routed to specified designs without encountering restrictions or issues associated with the instability of traditional cladding products while maintaining its durability.

The most popular designs are:

- Open jointed
- Square edge
- Shiplap
- Tongue and Groove.
- Other designs are of course possible.

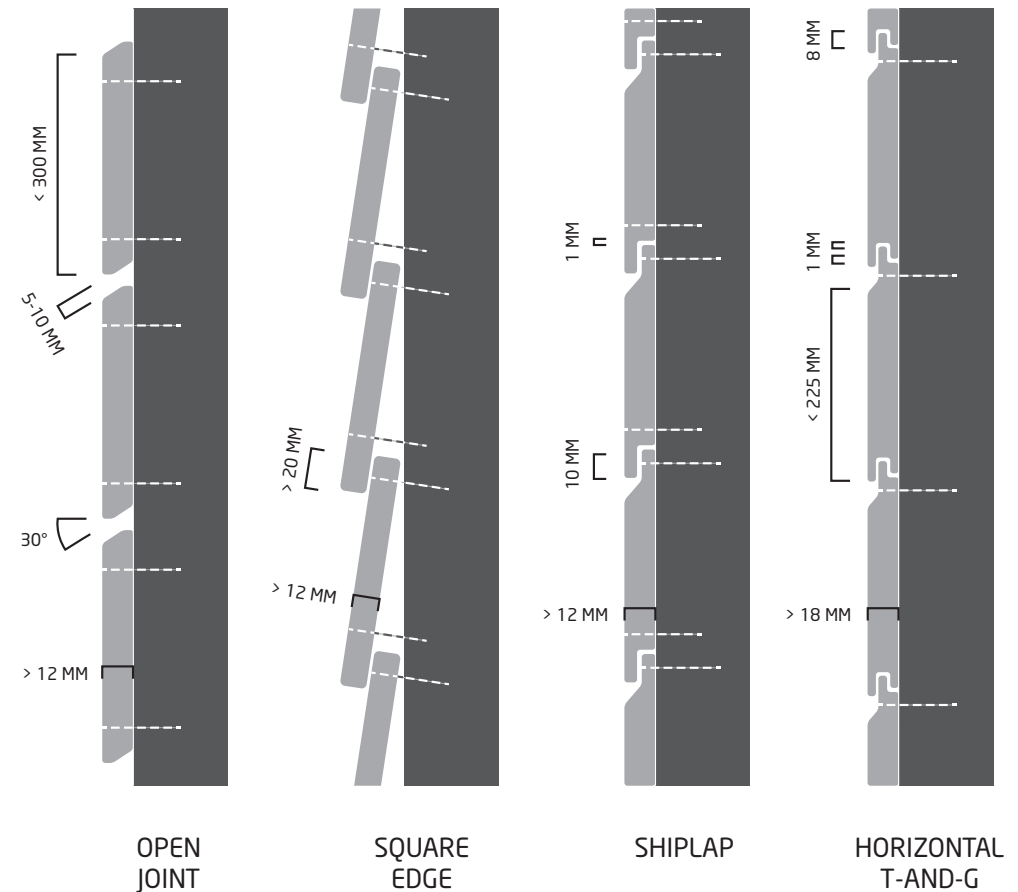

Horizontal boarding

When mounted horizontally, the fixing can be made invisible.

<300 MM face width

For horizontal boarding not exceeding 300 mm face width, the open joint chamfered boards should have a 5 - 10 mm gap between the boards at the outer face. The vertical overlaps of square and feather edge should be at least 20 mm.

When choosing a shiplap profile, the minimum vertical overlap can be reduced to 10 mm, but there should be at least a 1 mm gap between rebate and board / up stand below (see also the section on joints on page 10).

<225 MM face width

Horizontal tongue and grooved boards should not exceed 225 mm face width. The depth of the tongue should be at least 10 mm, with at least a 1 mm gap between tongue and groove shoulders. The boards should always be installed with the tongue upwards, to prevent water penetrating the profile.



Vertical and diagonal boarding

The board designs suitable for vertical boarding are (overlapping) square edge, shiplap and tongue and groove.

When installing the profiles vertically at least two fasteners per board are necessary and at least one of these fasteners, such as a nail will be visible. It is recommended to limit the board lengths to the storey height, and end joints must relate to batten positions.

A double sub frame is best practice where horizontal fixing battens are fastened on vertical counter battens (see figure opposite). The horizontal battens should be chamfered at the top side, shedding water into the cavity. The lowest batten should slant inward at the bottom, creating a drip lip at the intersection with the counter battens.

If only horizontal (fixing) battens are used, additional measures need to be taken to ensure sufficient ventilation. For example, making cut-outs in the battens or interrupting the battens at regular intervals and staggered relative to each other. In this case it is preferable if the horizontal battens are chamfered on the top edge to shed any water outwards.

<225 MM face width

For vertical boarding not exceeding 225 mm face width, the overlap distance for board on board fixing should be at least 15 mm. Board widths can vary between the inner and outer layer, but fixings through the outer boards should never pass through the board behind, to avoid splitting.

It is also possible to use an open joint, with a 5 – 10 mm gap between boards. The edge sides of the boards should be slanted outward, with a gap of at least 5 mm between board ends. Note that by leaving the joints open, the cavity and the sub-frame is visible, and a UV-resistant breather membrane must therefore be applied.

<175 MM face width

The face width of the shiplap profile should be limited to 175 mm (15 mm thickness), while the face width of the tongue and groove profiled boards should not exceed 150 mm (18 mm thickness). The groove should be at least 10 mm deep, with a 1 mm gap between tongue and groove and shoulders.

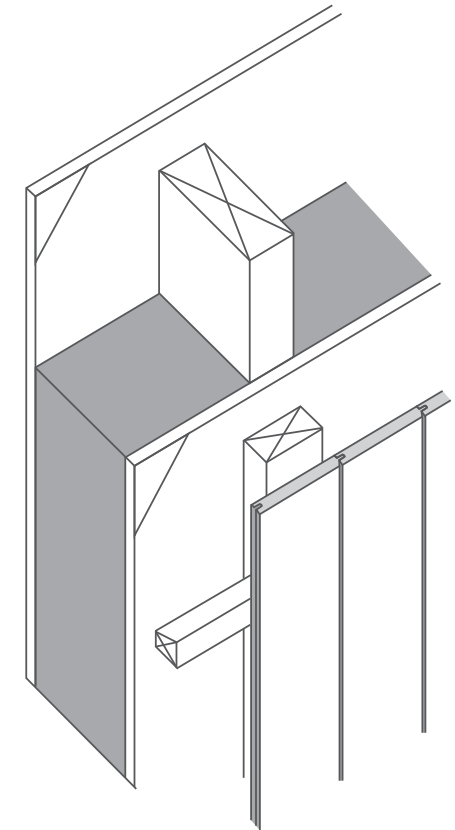

Grooved panels

Full panel utilisation width and length can be used and may include design requirements such as routing into the surface to create the impression of traditional joint types or novel artistic design.

Please note that when fixing this type of panel to the sub- frame, it is recommended using a fixing system suitable for panels (see the chapter on panel cladding; from page 12). In any case the structural integrity and stability of the entire fixing system of the grooved panel should be checked.

Ventilation

To ensure that rainwater and condensation behind the boarding is removed and the insulation behind the panels will not lose its effectiveness, a continuously ventilated cavity should be present behind the outer decorative layer. This cavity is ventilated through the ventilation in- and outlets situated at the top and bottom of the façade (at least 200 mm² per m² cladding). It is recommended that the depth of the cavity behind the cladding should be at least 20 mm.

Note that the cavity depth as well as the minimum size of the ventilation in- and outlets must be in accordance with applicable building standards and regulations and that a water repellent, breathable membrane (UV resistant when joints are left open) is applied at the back of the cavity. An insect mesh might be required in ventilation in- and outlets and/or in case of open joints.

Although not a technical requirement for MEDITE TRICOYA EXTREME (MTX), it is recommended for aesthetic reasons that cladding boards are positioned on the façade in such a way that no direct contact with the soil can take place. Furthermore, mounting the boards in the splash zone, between ground level and a height of 200 to 250 mm, will lead to a reduction in service life of any coating (in case of a paved surface).

Applying a gravel section below the cladding is recommended.

Joints

MTX cladding boards need to be installed with a mutual distance of at least 1 mm. When meeting other construction elements and/or between the lengths of two boards, a free space of 5 mm should be allowed for.

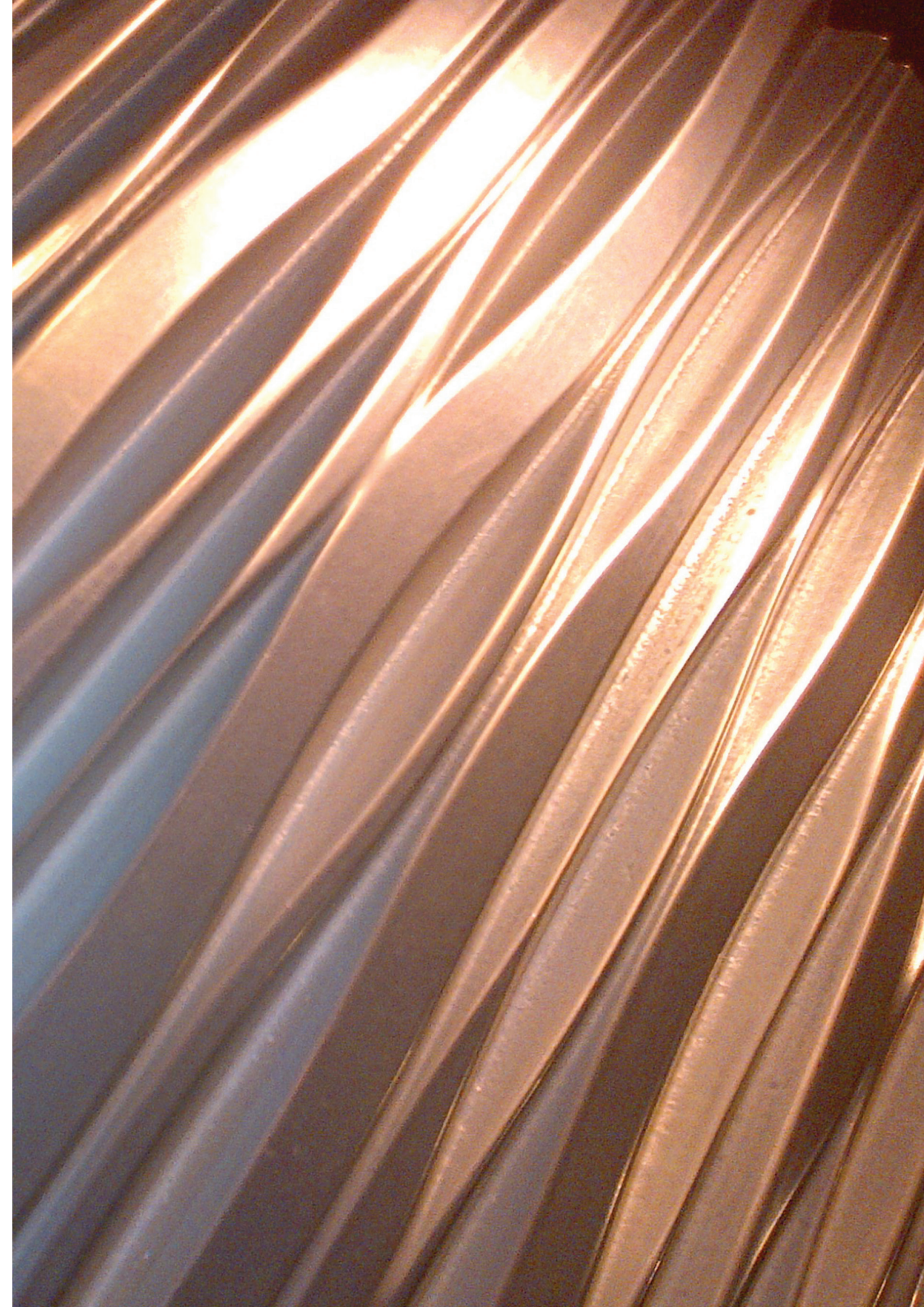



Fasteners and placing

MTX can be face fixed (and in some cases secret) onto the wooden sub-frame with ring shank (or other improved) nails or screws (raised head or round head), made of stainless-steel type A2 or A4.

Stapling is not recommended, nor is it to drive the nail or screw heads into the wood. T-nails should not be used for external cladding as they offer little resistance

to axial withdrawal. Lost head nails should also be avoided as they offer little resistance to pull-through.

When using screws, it is recommended to predrill the holes in the MTX with a diameter which is 1 mm smaller than the screw shank. Nail holes should be predrilled to 80% of the diameter.

The recommended point side penetration of nails into the timber battens is:

- Smooth nails: 12d*
- Ring shank and other improved mails: 6d (grooved panels: at least 10 d)

*d = shank diameter of the fastener

If the nail head is at least 2d it is assumed pull-through will not occur, because the pull-through resistance exceeds the withdrawal resistance. As a general rule, the length of a standard nail (and therefore also the minimum sub-frame thickness) will be approximately 2,5 x board thickness and with ring-shank and other improved nails standard nails approximately 2 x board thickness.

Screws have a greater axial strength than nails, and are therefore recommended for use with grooved panels. There are no general guidelines on withdrawal capacity for the most common dowel type fasteners like screws used with standard timber cladding.

To ensure a durable and lasting fixation, the boards should be fixed with at least 75 mm clearance to the end of the board (predrill hole to 1 mm less than the shank diameter or 80% of nail diameter). The minimum distance to the top and bottom edge of the boards is 25 mm.

Fixing distance

Support battens should not exceed 600 mm spacing, whether vertical or horizontal, to limit the span of the cladding board. For diagonal boards the spacing of the support battens should not exceed 400 mm, unless the battens are installed diagonally also.



PANEL CLADDING

When considering a rain screen system with panel style cladding, there are certain issues that need to be considered, among which the fixings used to make up the system. The fixing methods to consider for MEDITE TRICOYA EXTREME (MTX) include adhesive and screw fixings.

Please take note of the guidelines on possible fixing systems, ventilation, sub frames, joints and fasteners described in this brochure when designing cladding with MTX and ensure that the recommended fixing positions and fasteners are used. Contact our sales office for further support on possible fixing systems.

For façade cladding with MTX, the following conditions need to be considered:

- The panels need to absorb the wind load and convey this to the sub structure;
- The deflection of the panels due to this wind load should not exceed a two hundredth of the spanning distance (the distance between two fasteners on either direction)
- The maximum expansion under the influence of moisture and temperature changes is 1.5 mm/m, which needs to be considered with regard to joints.



Screw fixing on a timber sub-frame

Screw fixing is the most traditional form of fixing and is likely to be the least expensive system to be considered as a MTX façade rain screen system. Screws can pass through the cladding panel and into timber battens placed behind the cladding.

Sub frame

Vertical timber battens, no smaller than 38 mm x 38 mm in section, should be used to support the cladding to the supporting wall or cladding structure. For the outer corner, a corner infill piece can be used to protect and finish the corner of the façade.

For the inner corner, a shadow gap of no less than 3 mm is normally used; with the rear battens masked using a flexible black or dark grey joint cover strip material.

Fasteners

Screws for face fixing should be made of stainless steel A2 or A4. The length of the screw should be at least 25 mm + panel thickness (+ any spacers). If the screw head diameter is at least 5 mm bigger than the hole diameter, it is assumed pull-through will not occur, because the pull-through resistance exceeds the withdrawal resistance. Holes for the fasteners should be pre-drilled, slightly over-sized ($\geq 120\%$) compared to the shank diameter, to allow for panel and sub-frame expansion.

Screws should be positioned at least 25 mm from the edge of the panel and at least 75 mm from corners. The maximum edge distance for this type of fixing is 15 x panel thickness.

For further design guidance and pull out strengths, the fastener manufacturer should be contacted. For guidelines of the maximum fixing distances that follow from the maximum acceptable deflection of the panels, see the graphs on page 14.



Invisible fixing with adhesive

Hidden fixings are often favoured in a rain screen cladding system as the structural connection is hidden, with no need for mechanical rivet or screw heads to be seen on the face of the cladding panels. The structural bonding of a façade panel to a vertical wooden or aluminium rail system offers the opportunity to provide a non-mechanical secret fix mounting.

Sub frame

MTX is suitable for gluing on a vertical timber or aluminium sub-frame. To allow for the relative movement of the façade panel in relation to the sub-frame, it is very important that the adhesives used remain permanently elastic.

Adhesive systems

Testing has shown good results with a number of different adhesive manufacturers. Suitable adhesive systems typically consist of (permanent) elastic adhesive, fixing tape, cleaner and primers for both the panels and the sub-frame.

Please contact us for more information on tested adhesive manufacturers.

Please contact the manufacturers of gluing systems for information on preparation and installation of the framework and the finished panels.

The fixing distance will have to be determined in consultation with the adhesive manufacturers and according to the valid building codes and regulations, but rely amongst others on the wind load. For guidelines of the maximum fixing distances that follow from the maximum allowed deflection of the panels, we refer to the graphs on page 14.

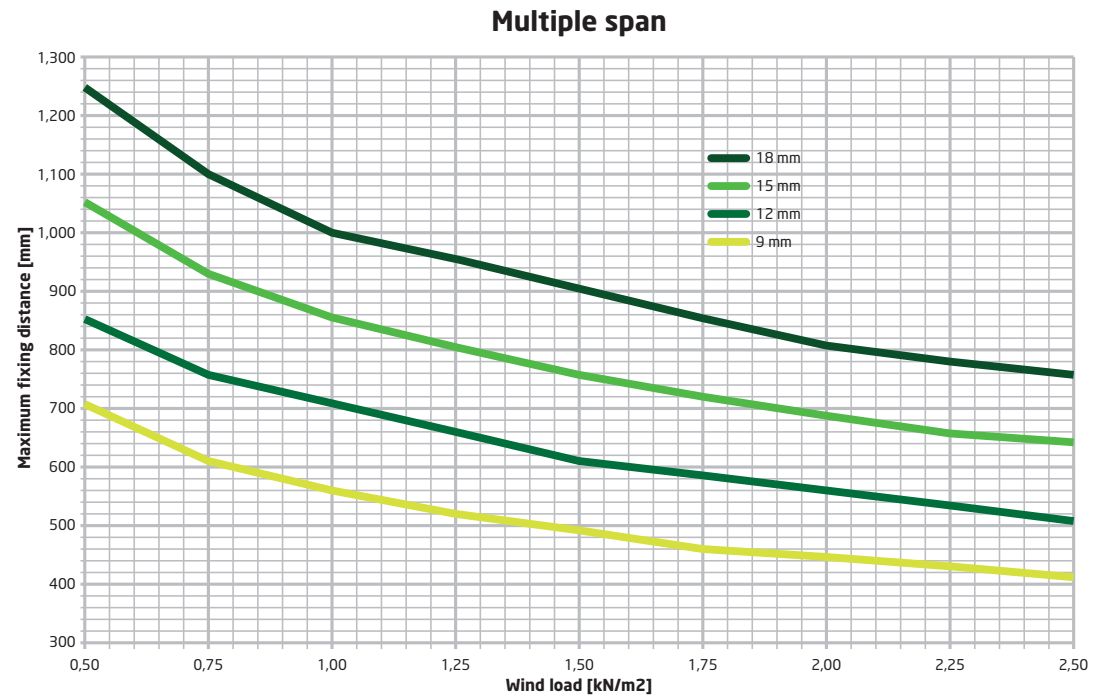
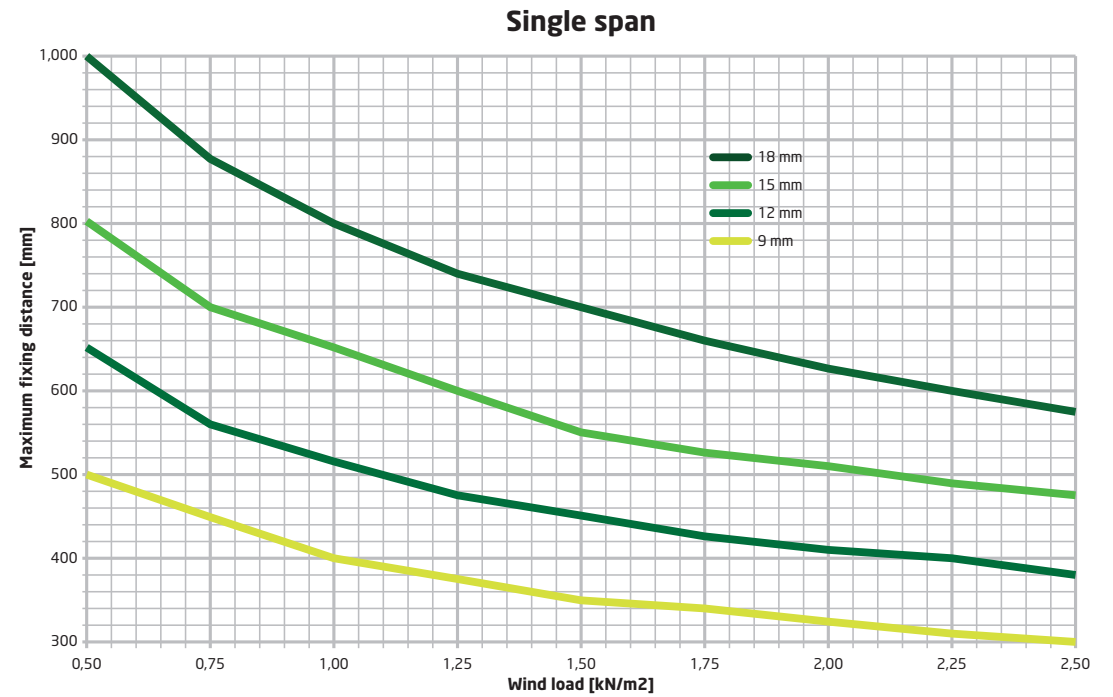

Fixing distances

The distances between the supports is crucial to the ultimate performance of the MEDITE TRICOYA EXTREME (MTX) cladding panel.

As a general guideline, these graphs depict the maximum fixing distances for the different panel thicknesses, based on the maximum tolerable deflection of the panel (1/200 of the span).

Note that the maximum fixing distance of multiple span panels (three or more vertical fixings) is higher than that of single span panels (two vertical fixings per panel), due to increased stiffness.

The strength of the total system (spacing, number and type of fixing required due to wind loading) must at all times be checked by a licensed engineer.

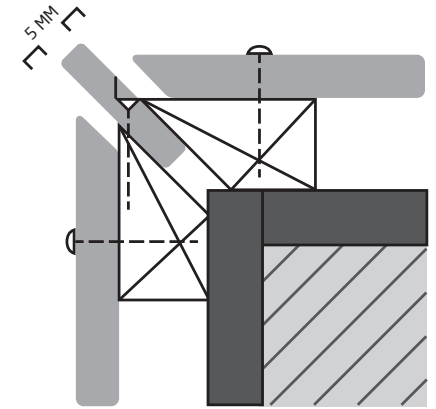
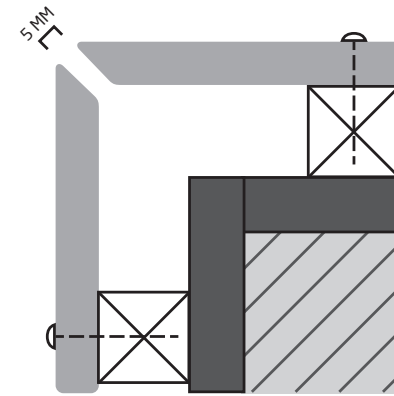
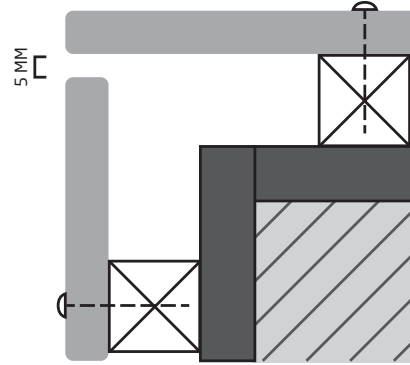
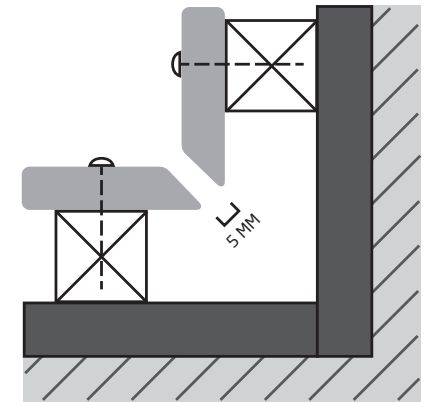
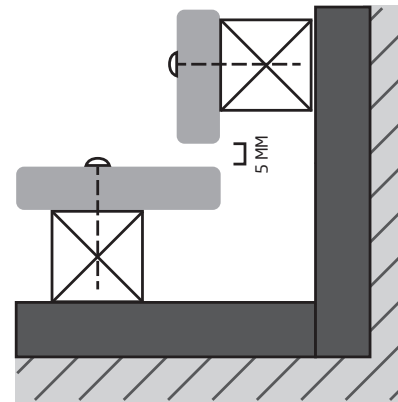

Corner details

Corner solutions for MTX as cladding can be detailed in numerous ways, both with and without incorporating profiles. It is best practice when a board meets another construction part (or another board) a gap of at least 5 mm should be provided. This gap may not always be necessary based on design and components used. Depending on the applicable national building code, to which you should refer, cavity barriers may be needed at corners.

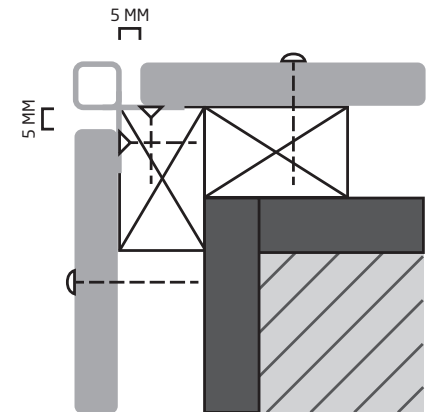
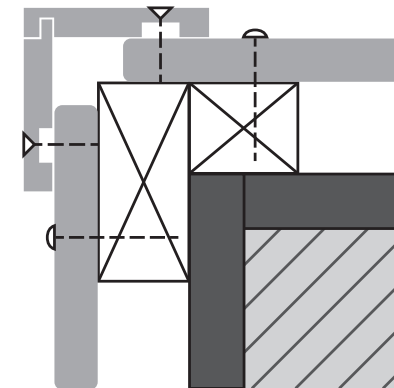
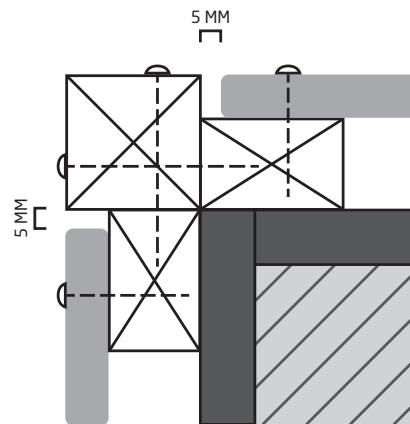

Ventilation

MEDITE TRICOYA EXTREME (MTX) should be installed in a ventilated façade system.

This type of façade system is characterised by continuous ventilation behind the outer decorative layer, through the ventilation in- and outlets situated at the top and bottom of the façade (at least 200 mm² per m² cladding). This way, rainwater and condensation behind the cladding is removed and the insulation behind the panels will not lose its effectiveness. It is recommended that the depth of the cavity behind the cladding should be at least 20 mm.

Note that the cavity depth as well as the minimum size of the ventilation in- and outlets must be in accordance with applicable building standards and regulations and that a water repellent, breathable membrane (UV resistant when joints are left open) is applied at the back of the cavity. An insect mesh might be required in ventilation in- and outlets and/or in case of open joints.

Although not a technical requirement for MTX, we do recommend for aesthetic reasons that panels are positioned on the façade in such a way that no direct contact with the soil can take place. Furthermore, mounting panels in the splash zone, between ground level and a height of 200 to 250 mm, will lead to a reduction in service life of any coating (in case of a paved surface). Applying a gravel section below the cladding is recommended.

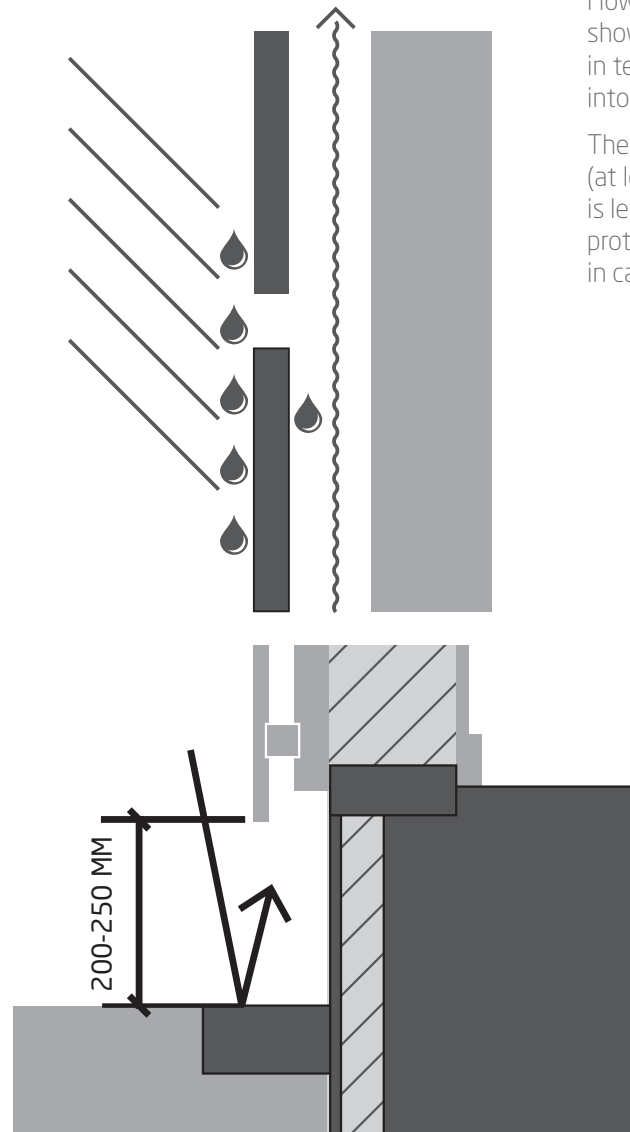

Note that panels should be fitted with spacers and not fitted flush to any masonry or brickwork.

Joints

Considering the circumstances, that MTX is used in, the panels will not expand or shrink more than 1.5 mm/m in practice. However, the material will be mounted onto a sub-frame that shows a significant expansion and shrinkage due to changes in temperature and/or humidity, which needs to be taken into account.

Therefore, MTX cladding panels need to be installed with (at least) a 5 mm free space around the edges. When the joint is left open, the sub frame supporting the panels should be protected (full width) by a suitable weather resistant joint tape in case of battens.

OTHER EXTERIOR APPLICATIONS

Fascia and soffits

MEDITE TRICOYA EXTREME (MTX) can be used for soffits or fascia finish for roof ends. Although different sub-frames are possible, the application onto battens (timber sub-frame) is the most usual. It is recommended to limit the maximum height of the boards as stated in the table below and to fix the board vertically at two places. The roof lining boards can be fastened visibly with wood screws, or they can be glued onto the sub-frame.

It is also possible to fix the boards invisibly by using screws at the top of the board (which will be concealed by the roof trim) and fitting the tongued bottom edge into continuous (aluminium) U-shaped rails.

	PANEL THICKNESS	
	9mm	12mm
Board height ≤	250mm	400mm
Horizontal fixing distance ≤	500mm	500mm

Spandrel panels

Due to its durability and enhanced dimensional stability, MTX is suited for the application of walling between structural members e.g. a timber framed building. The panels can be as large as the numbers in the table below, provided the panels are fitted in a (sufficient stiff) window frame on all edges. The size of the panel is limited in one direction only (either vertical or horizontal).

Panels with a length and width exceeding 1 metre should have an intermediate support installed. For the resulting two surfaces, the limits in the table below apply.

Curved panels

Because of its superior properties, MTX can easily be curved and bent, according to the specifications opposite.

Curved boards can be fixed with the fasteners described in the chapter on cladding panels. In case of adhesive, the outer sides need to be fastened additionally with wood screws.

DIMENSIONS	6mm	9mm
Curve	2,440mm	2,440mm
Radius (R)	620mm	977mm
Angle (θ)	120mm	145mm
Chord	1,100mm	1,900mm
Level	900mm	750mm
Battens (c.t.c.)	300mm	400mm
Fixings edge (c.t.c.)	270mm	300mm
Fixings intermed. (c.t.c.)	300mm	300mm

PANEL THICKNESS	MAX PANEL WIDTH
9mm	550mm
12mm	700mm
15mm	850mm
18mm	1,000mm

Exterior ceilings

MTX is also suited for use in horizontal applications like exterior ceilings (e.g. shopping centres, car ports and overhangs). The fixing systems described in the previous pages can be used:

- Cladding boards
- Screw fixing on a timber sub frame
- Invisible fixing with adhesive.

The specific guidelines of the chosen fixing systems apply. We recommend limiting the support distance for cladding boards to 450 mm, and the fixing distance of cladding panels to 75% of those stated in the graphs on page 14 due to panel deflection by its own weight in a horizontal application.

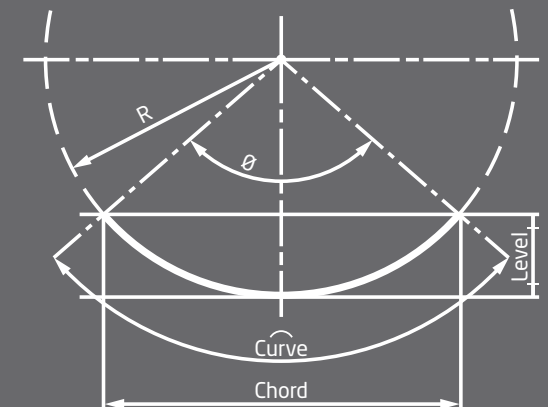

COATINGS

There is no need to finish MEDITE TRICOYA EXTREME (MTX) from a technical performance perspective, in respect of attributes such as decay resistance and dimensional stability. However, MTX is susceptible to weathering in outdoor circumstances.

Uncoated panels used outdoors will weather and roughen due to UV and biological processes that take place within the wood fibres and at its surface. Where a lasting aesthetic appearance is required, a high-quality coating system will protect against this weathering effect and minimise discolouration.

MTX is all-natural and non-toxic so mould growth can occur if MTX is left uncoated, though any moulds, stains, mosses or algae will not cause rot within MTX. Common mould growth can be avoided by using a suitable outdoor primer which addresses mould growth. Staining and discolouration can be avoided by using a high-quality UV resistant coating. This also protects the wood from accidental staining.

The compatibility of MTX with various coating systems compares well with wood in general and it may be finished with commonly used products.

Please note: coating formulations vary from supplier to supplier and, of course, processes vary depending on the application equipment used and end-product design.

Despite our excellent record of compatibility, we highly recommend having your coating suppliers involved in the process as they have an in-depth knowledge of their products, application and how to determine the performance of the finished product.

For detailed information on certain coating suppliers, we refer to the download section of our website, please log onto www.mdfofb.com.



Preparation

- MTX moisture content should be below 10% before processing and coating application
- All edges should be rounded to 3mm radius
- All edges and machined surfaces should be effectively sealed using an end grain sealer which is compatible with the coating system
- Coating specifications and guidelines set out by the coating manufacturer must be followed e.g. surface preparation, wet film thickness and drying techniques
- All surfaces and edges should be coated with the same system
- The coating system should be fully finished prior to installation. If site finishing is required, a primer and mid coat should be factory applied and the topcoat applied before the coated MTX gets wet on site
- All gaps/holes should be sealed to prevent water entering the construction
- Opaque coatings with calcium carbonate (chalk fillers) may cause coating blistering on MTX and should be avoided. Please consult coating manufacturer
- Customers should review the location of a site to determine if it would classify as high risk for surface biological growth and would necessitate a biocide additive in the coating formulation

Opaque coatings (film forming)

The opaque and (semi-) translucent coating systems should be applied with a minimum dry film thickness that corresponds to the requirements of the end use, location and/or coating manufacturer's instructions.

Translucent coatings (non-film forming)

As MTX does not have a wood grain look but a uniform fibre appearance, translucent coatings are not recommended. If a translucent coating is desired, a mid to dark base stain should be uniformly applied and then a translucent topcoat. The coating manufacturer should be involved to provide expertise and guidance.

Further information on all coatings may be obtained directly from coating suppliers. A wide range of coatings will be suitable for use with MTX. The table opposite contains industrially applied coating systems that are specifically tailored for and warranted with MTX.

Note: These systems may vary from country to country, we therefore recommend that advice is sought directly from the coating company in your area.

COATINGS REDECORATION / MAINTENANCE SCHEDULE

Various coating suppliers have tested their systems on MEDITE TRICOYA EXTREME (MTX) and provided redecoration or maintenance schedule under different exposure levels.

Supplier	System	Exposure level		
		Mild	Medium	Severe
Teknos	Factory finished - Opaque	10 years	7 years	6 years
Sikkens	Factory finished - Opaque	6 years	6 years	6 years
	Brush-applied - Opaque	6 years	5 years	4 years
Remmers	Factory finished - White or light coloured paints	10-12 years	7-9 years	6-8 years
	Factory finished - Dark coloured paints	8-10 years	6-8 years	6-7 years
Anker Stuy	Factory finished - White or light coloured paints	6-8 years	6-8 years	4-6 years
	Factory finished - Dark coloured paints	4-6 years	4-6 years	3-4 years
Dulux Trade	Opaque (brush-applied)	8 years	6 years	5 years
PPG	Factory finished - Opaque	8-10 years	6-8 years	5-6 years

1- Detailed information on the coating systems are provided in the manufactures specific documents available on the website.

2- Indicative guidance on exposure levels are :

- a. Medium exposure level corresponds to 2nd floor and above or on a hillside,
- b. Severe exposure level corresponds to mountainous or coastal climate.

3 - Coating manufacturers should be contacted by the end-user to get the details on the coating systems, applied weights and warranties.

Laminates

The surface of MEDITE TRICOYA EXTREME (MTX) can be covered or overlaid with wood, HPL, CPL and melamine papers. A number of industrial processors are successfully developing systems. For further information please contact MEDITE.

Manually applied coatings

To ensure best results and performance, any coating on MTX should be fully factory/industrially applied. If site finishing is required, a primer and mid coat should be factory applied and the topcoat applied before the coated MTX gets wet on site. The same guidelines set out by MEDITE (page 18) and coating manufacturers must be followed for manual application of coatings. Brush application will achieve a wet film thickness of around 70 – 80µm. Multiple coats will be needed to build the dry film thickness required for an exterior grade system. Light sanding with a high-grit sandpaper between coats will improve the surface finish.

Gluing

MTX can be glued together with D4 (EN204) class adhesives. In general MTX can be glued using PU, RPF, or EPI wood adhesive systems.

MEDITE SMARTPLY has a range of technical literature to assist in the use of MTX. Please refer to the product page on the website for these documents. Contact us for further assistance.

www.mdfosb.com/mtx

DISCLAIMER:

The information contained in this document is provided as guidance by MEDITE SMARTPLY. It is the responsibility of the customer and/or end-user of MEDITE TRICOYA EXTREME (MTX) to ensure that the final use of the panel is checked by the proper authorities on conformity with local circumstances, building codes, regulations and standards and checked by a licensed engineer.

MEDITE® is a registered trademark of MEDITE EUROPE DAC ("MEDITE") and cannot be used or reproduced without MEDITE's written permission. TRICOYA® and the trimarque device are registered trademarks owned by Accsys Technologies, the trading name of Titan Wood Ltd.



More information

For more information please contact our sales office:

UK: +44 1322 424900

Other brochures and information sheets on specific subjects like machining and handling, fasteners and specific coatings can also be found in the download section of

www.mdfosb.com