

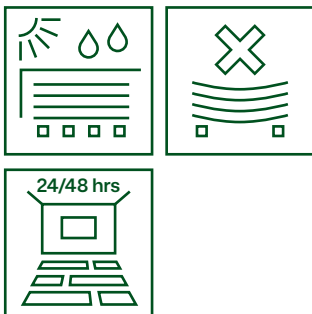

# Installation guide for WISA®-Sprucefloor

WISA-Sprucefloor is a purpose made plywood panel specifically designed for flooring. Lightweight panels are tongued and grooved on all four sides making installation easy and effortless. Panels measure 2400 mm x 600 mm in 18 mm or 22 mm thicknesses – ideal to install in all joisted or floating floor applications.



## Storage:

Store panels in dry conditions, on a flat, level surface, clear of the ground.

## Handling:

Always handle with care to avoid damage to the tongue and groove edges.

Do not move opened pallets with mechanical handling equipment.

Wear gloves and safety glasses to avoid splinters.

## Conditioning:

Loose-lay the panels in the area where the floor is to be fixed at least 24 hours before fixing. This will acclimatize the boards to the normal conditions of the room, such as relative humidity and temperature. The frame structure should be sufficiently dried before fixing.

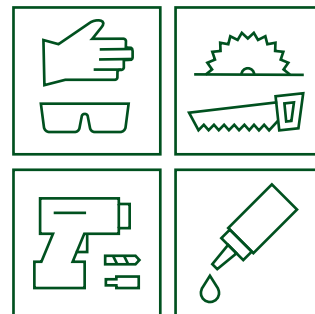

## Fixing

Planning your flooring project well in advance will make actual installation easier and faster.

Make sure you have all the equipment you will need on hand. Do not forget safety gear, gloves and safety glasses, and wearing ear plugs is worthwhile if you plan to use machined tools, e.g. a circular saw.

For the joisted/battened floors fixings use countersunk screws or annular ring shank nails at least 2.5 times the panel's thickness.

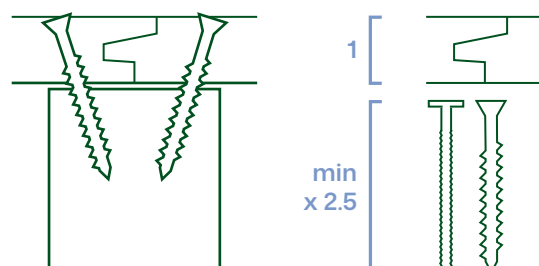

# Joisted and battened floors

## Subfloor preparation:

Ensure joist are suitable for the application according to the structural plan, with, for instance, solid timber or "I"beams.

- Regularise timber joists to provide a straight and level surface
- When using "I" beams please follow the manufacturers installation instructions
- Span according to the structural plan, either c/c 400 or 600 mm depending on point load
- Support the floor perimeter continuously on noggins
- Any access traps for under floor services should be preplanned and support provided to all sides of each trap

## Fixing

- Lay panels across the joists at right angles.
- Start at one corner and always with a full length panel. Place the tongue edge against a wall. (pic 1.)
- Saw off the tongue from the panel next to the wall.
- Leave an installation gap of min. 5 mm between wall and floor, use wedges.
- Please note that if the floor is over 15 m long, it should have intermediate expansion gaps every 15 metres.
- Support panel's short edges on a joist.
- The last panel of the row must be cut to size. You can use the cut piece to start a new row, just remember that the panel must be supported by no less than 3 noggins so the minimum length is 800 mm. (pic 6.)
- Stagger end joints. (pic 4.)
- Use a D3 or D4 type adhesive to glue all joints. You can also glue the panels to joists, according to the structural plan, to further stiffen the flooring and minimize the risk of squeaking. (pic 2.)
- Tightly butt joints using a piece of tongued and grooved panel and a hammer. (pic 3.) - Never hit the edge directly as it might destroy the edge.
- Fix the panels to joists using countersunk screws (recessed 2 mm below the panel surface) or galvanized annular ring shank nails at least 2.5 times the panel's thickness.
- Space fixings not less than 10 mm from the panel edge (at 150 mm intervals round the edge and at 300 mm intervals elsewhere). (pic 5.)

# Installation

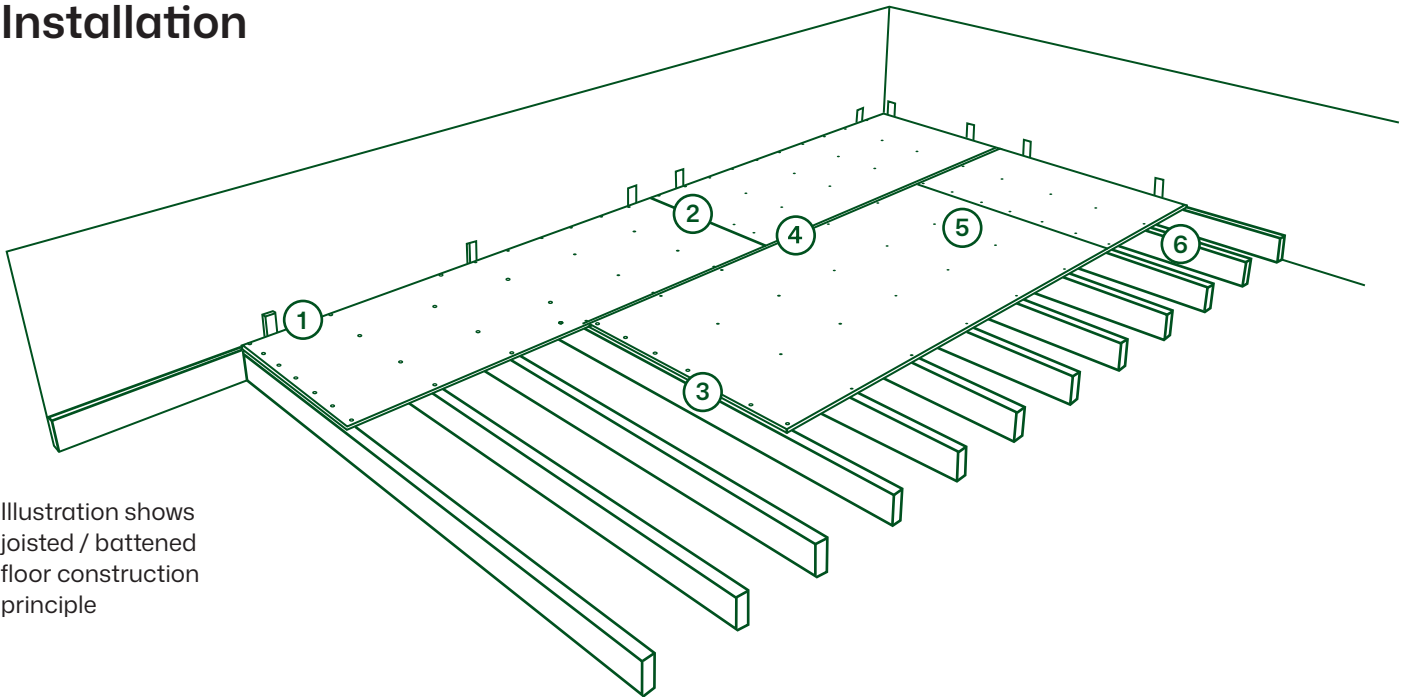
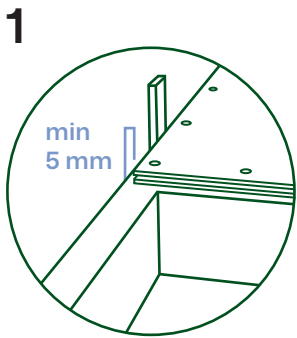
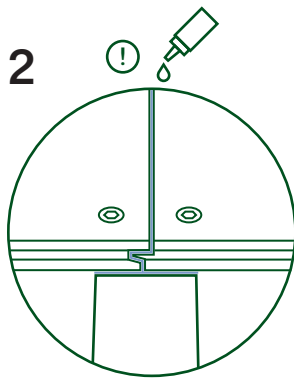

Illustration shows  
joisted / battened  
floor construction  
principle



1  
Leave an installation gap  
of min. 5 mm between  
wall and floor, use wedges.



2  
Use a D3 or D4 type adhesive to  
glue all joints. You can also glue  
the panels to joists, according to  
the structural plan.

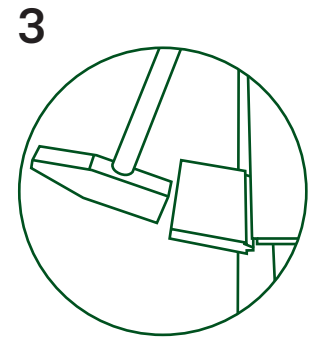

3  
Tightly butt joints using a piece  
of tongued and grooved panel  
and a hammer.

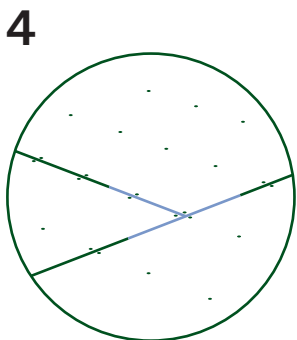

4  
Stagger end joints.

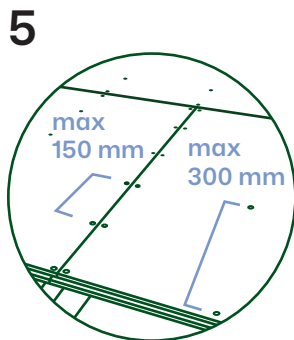

5  
Space fixings not less than  
10 mm from the panel edge.  
At 150 mm intervals round  
the edge and at 300 mm  
intervals elsewhere.

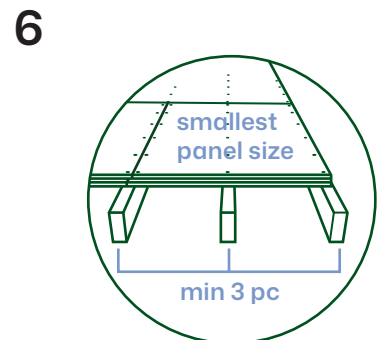

6  
Remember that the panel  
must be supported by  
no less than three noggings.

# Continuously supported/Floating floor

## Subfloor preparation:

- Make sure the floor is dry, level and free from dust and debris

## Fixing

- Lay an underlay e.g. polythene sheet or other approved moisture barrier, according to the specifier or structural engineer's plan.
- Start at one corner and always with a full-length panel. Place the tongue edge against a wall.
  - Saw off the tongue from the panel next to the wall.
- Leave an expansion gap of 10–15 mm between wall and floor, use wedges.
- Install the panels one row at a time.
- Cut the last panel of the row to size. Use the cut piece to start a new row.
- Stagger end joints.
- Use a D3 or D4 type adhesive on all joints. You can also glue the panels to underlay if specified in the structural plan.
- Tightly butt the joints using a piece of tongued and grooved panel and a hammer. Never hit the edge directly as it might destroy the edge.