

Fitting Guide

EGGER offers two fitting methods for its Advanced Structural Flooring Boards.

The Egger

ADVANCED

Fitting Guide

- A) The EGGER Advanced Structural Flooring System, using EGGER Joint & Joist Adhesive and minimal mechanical fixings
- B) The EGGER Advanced Glue Only System, using EGGER Joint & Joist Adhesive only

Method A is recommended for all new builds that require a warranty provider's guarantee.

Both methods are covered by the EGGER Advanced Lifetime Guarantee*.

Suitable for use with solid timber joists and engineered joists. Please follow joist manufacturers' recommendations in conjunction with fitting EGGER Flooring grade chipboard (see **Fitting Notes** on page 3).

A) The EGGER Advanced Structural Flooring System (ref: KIWA BDA Agrément® BAF-19-129-S-A-UK)

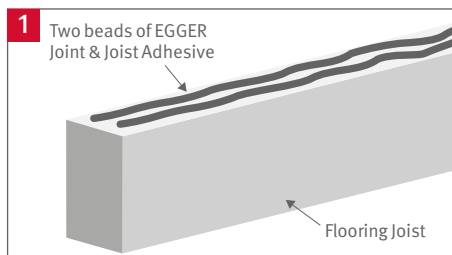

Apply two (approx 5 mm) parallel beads of EGGER Joint & Joist Adhesive to the top of the joist along the first row of boards.

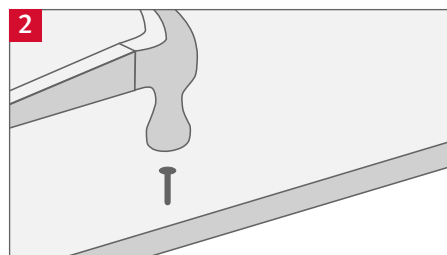

Lay the boards across the joist and fix the first row of boards with one mechanical fixing per joist along the perimeter edge, minimum 8 mm from the joint edge.

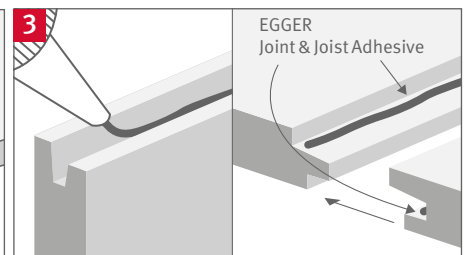

Apply EGGER Joint & Joist Adhesive directly to the tongue and groove of the profile joint along the length of each board and ensure that the entire joint is bonded once the boards are butted tightly together. Adhesive should foam out of the board joint. This will enhance the protection of the joint. Excess adhesive should be left to dry. Any joints where the adhesive has not appeared to foam over the joint must be re-sealed using additional adhesive.

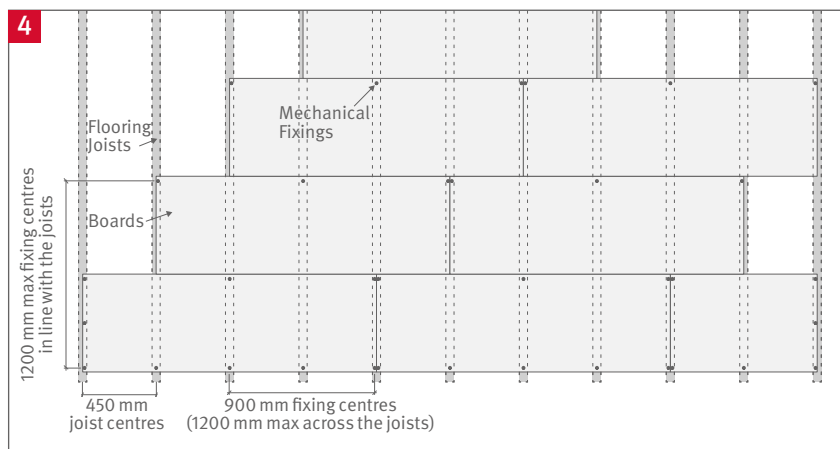

Follow the recommended fixing pattern every 1200 mm using mechanical fixings. For every short end joint, an additional mechanical fixing is needed. All short end joints should always fall on the centre of a secured joist including perimeter edges. Where this is not the case, please refer to the relevant building guidelines. Apply EGGER Joint & Joist Adhesive along the next row of joists and stagger the new row of boards by approximately half a board to form a brick bond laying pattern. Repeat the steps.

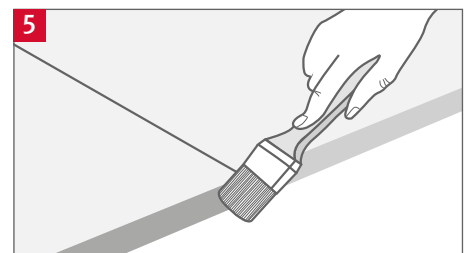

Seal any exposed mechanical fixings, perimeter edges, cut edges and stairwells using EGGER Joint & Joist Adhesive. Once the building is watertight, excess adhesive can be removed with a scraper.

B) The EGGER Advanced Glue Only System

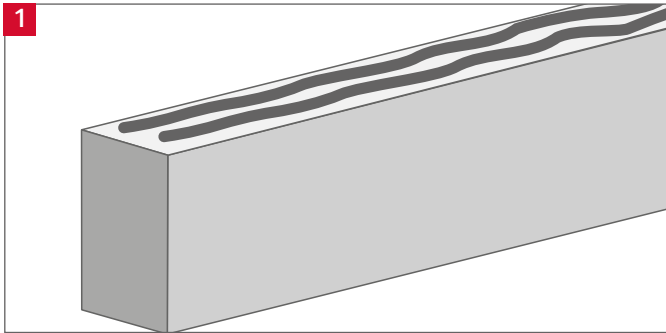

1 Apply two parallel beads of EGGER Joint & Joist Adhesive to the top of the joist along the first row of boards.

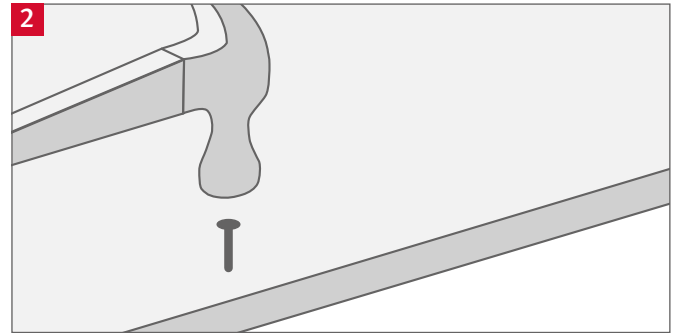

2 Lay the boards across the joist and fix the first row of boards with only one mechanical fixing (2.5 times the board thickness) per joist along the perimeter edge, minimum 8 mm from the joint edge.

All exposed fitting heads must be sealed with EGGER Joint & Joist Adhesive to prevent potential moisture ingress.

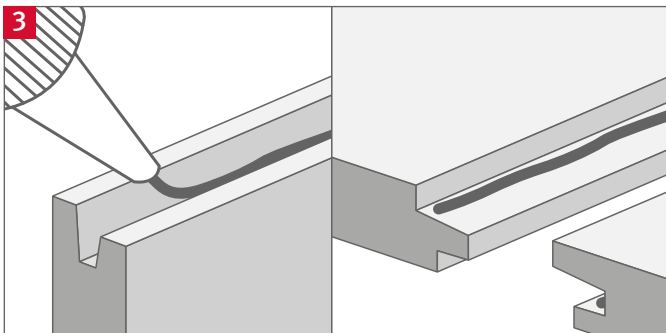

3 Apply EGGER Joint & Joist Adhesive directly to the groove and shoulder of the profile joint, continuing down the length of each board to ensure that the entire joint is bonded once the boards are butted tightly together. Adhesive should foam out of the board joint. This will enhance the protection of the joint. Excess adhesive should be left to dry.

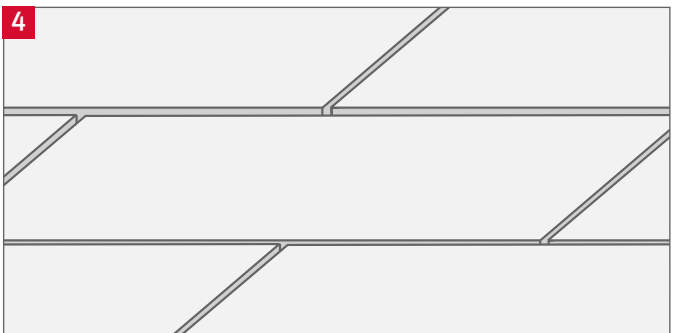

4 Apply EGGER Joint & Joist Adhesive along the next row of joists and stagger the next row of panels by approximately half a board to form a brick bond laying pattern. Repeat steps (excluding step 2) and note that care should be taken when walking on newly laid boards.

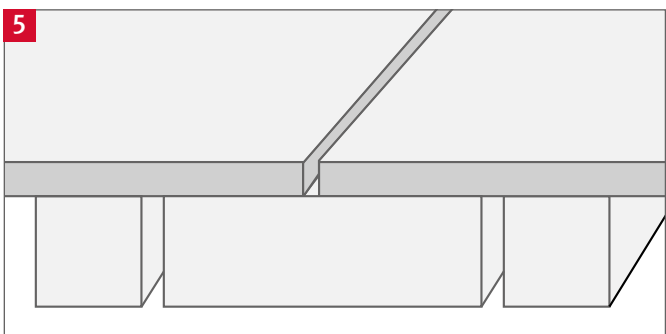

5 All short end joints should always fall on the centre of a secured joist, including perimeter edges. Where this is not the case, please refer to the relevant building guidelines.

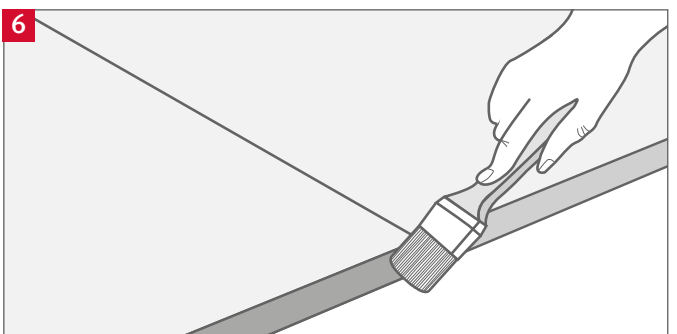

6 Exposed fitting heads, perimeter edges, cut edges and stairwells must be sealed using EGGER Joint & Joist Adhesive.

Once the building is watertight, excess adhesive can be removed with a scraper.

Fitting Notes

Joist Centres

On joists up to 450 mm centres, 18 mm or 22 mm panels may be used, but on joists up to 600 mm centres 22 mm panels must be used.

Expansion Provision

An expansion gap of 10 mm or 2 mm per metre run of floor, whichever is greater, should be left against all walls. Intermediate gaps (min. 10 mm) should be incorporated for floors in excess of 10 m long e.g. corridors.

Mechanical Fixings

The basic form of a mechanical fixing that we recommend is annular ring shank nails. All mechanical fixings must be no more than 8 mm from the joint edge. Mechanical fixings need to be 2.5 times the board thickness.

Along the short-end perimeter of the first row of boards, an additional mechanical fixing is needed every 300 mm.

The EGGER guidance on mechanical fixings is a minimum requirement for our system. Where floor designs/requirements differ, we recommend seeking joist manufacturers' guidance on fixings, so long as our minimum requirement is met.

Adhesive Coverage

Bonding the board to the joist and within the tongue & groove joint will typically require 1 bottle of EGGER Joint & Joist Adhesive per 6 boards (2400 mm × 600 mm).

EGGER Advanced Lifetime Guarantee

Use our Advanced Structural Flooring Boards, Joint & Joist Adhesive and one of our recommended fitting methods to be covered by our unique Lifetime Guarantee.

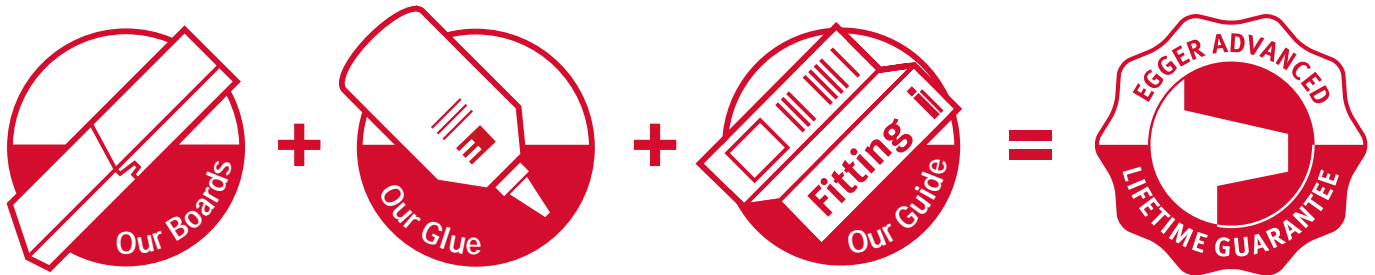

* Only applicable to the structural integrity of the EGGER Flooring Board.

For terms and conditions and further information on the EGGER Advanced Lifetime Guarantee, please visit www.egger.com/lifetime

www.egger.com/building

EGGER (UK) Limited
Anick Grange Road
Hexham
Northumberland
NE46 4JS
T 01434 602191
F 01434 613302
building.uk@egger.com

Building Products Hotline
For product information, technical advice
or general information:
T 0845 602 4444 (charged at local rate)
From R.O.I. please call: T 01434 613304
building.uk@egger.com

Online Technical Support
Visit our website for product
and technical information:
material safety data sheets,
technical data sheets,
certificates and test reports.
www.egger.com/building