

Field of Application Report

KFS Report PAR/10341/01 Revision C

Fire Resistance Standard: BS476: Part 22: 1987



Prepared for:

Halspan Ltd
Regent House
Regent Centre
Linlithgow
West Lothian
EH49 7HU



Assessed Product/System:

Halspan Optima Timber Door Type

Assessed Performance:

30 minutes fire resistance to BS476: Part 22: 1987

Issue Date

21 October 2025

Expiry Date

21 October 2030

Kiwa Fire Safety Compliance
Ground Floor, Suite A, Building 2
Bear Brook Office Park
Walton Street
Aylesbury, Buckinghamshire
HP21 7GQ

+44 (0)1844 275500
uk.firesafety@kiwa.com

Kiwa Fire Safety Compliance

Kiwa Fire Safety Compliance (KFS) is part of the **Kiwa UK Group**. The company is a specialist engineering consultancy delivering independent, honest and practical fire safety solutions to professionals across the built environment. The sought after fire safety advice protects life, preserves property and safeguards business continuity.

Formerly called International Fire Consultants, the company was established in 1985 to provide high quality and impartial technical expertise concerning fire safety. Since then the team of highly qualified Fire Engineers and Fire Safety Professionals have continued to deliver robust, innovative and cost-effective fire safety solutions, including Assessments, Designs and Inspections.

Kiwa Fire Safety Compliance lend their insight and practical expertise for: Fire Safety Engineering, Fire Risk Management, Product Evaluation, Fire Life Safety Systems, Expert Witness Testimony and Fire Protection Training, to developments of all sizes and complexities; from residential, education and healthcare structures to sporting venues, airports and iconic heritage buildings, such as historical royal palaces and stately homes.

Recognised internationally as the go-to professionals in all aspects of fire safety, Kiwa Fire Safety Compliance is one of the world's leading fire engineering and solution providers, trusted by many of the most prestigious construction firms, architects and estate owners.

HEAD OFFICE/CORRESPONDENCE ADDRESS:

Kiwa Fire Safety Compliance Limited
Ground Floor, Suite A, Building 2
Bear Brook Office Park
Walton Street
Aylesbury, Buckinghamshire
HP21 7GQ

[+44 \(0\)1844 275500](tel:+441844275500)
uk.firesafety@kiwa.com

REGISTERED ADDRESS:

International Fire Consultants Limited
Kiwa House
Malvern View Business Park
Stella Way, Bishops Cleeve
Cheltenham
GL52 7DQ

Registered No: 2194010

Private and Confidential

This report should not be manipulated, abridged or otherwise presented without the written consent of Kiwa Fire Safety Compliance.

Report Reference Number:	KFS Report PAR/10341/01 Revision C
Prepared on behalf of:	Halspan Ltd
Project:	Regent House Regent Centre Linlithgow West Lothian EH49 7HU
Issue Date:	21 October 2025
Expiry Date:	21 October 2030
Ref ID:	25716

Issue and Amendment Record

REV	DATE	AUTHOR	REVIEW	SECTION	AMENDMENTS
-	July 2010	DC	DJI		
Revision A	January 2016	DC	DJI		Revalidation, update of format, inclusion of additional test evidence and associated changes
Revision B	May 2020	CPH	DC		Inclusion of panel door design, feature grooves, steel door frames, revalidation, update of format, inclusion of additional test evidence and associated changes
Revision C	October 2025	CA	WL		Revalidation, update of format

Contents

1. Introduction	6
2. Use of this Report	6
3. Fire Test Evidence	7
3.1 General	7
3.2 Suitability of Fire Test Evidence	7
3.3 Use of BS and EN Test Evidence	8
3.4 Door Orientation	8
4. Approved Door Assembly Configurations	9
4.1 General Requirements/Notes	9
4.2 Door Assembly Configurations	10
5. Maximum Assessable Door Leaf Sizes	16
6. Hardware	16
7. Optima FD30 Constructional Details	17
7.1 General Requirements	17
7.2 Leaf and Overpanel Construction	18
7.3 Door Lippings	21
7.4 PVC Encapsulated Doors	24
7.5 Decorative Leaf Facings	25
7.6 Decorative Leaf Finishes	26
7.7 Decorative Timber Mouldings	27
7.8 Feature Grooves	28
7.9 Recessed Panels	28
7.10 Door Edge Protection	29
7.11 Overpanels	29
7.12 Underpanels	34
7.13 Timber Door Frames	35
7.14 Steel Door Frames	48
7.15 Aluminium Door Frames	49
7.16 Glazed Apertures	50
7.17 Air Transfer Grilles	61
7.18 Fanlights, Sidelights and Glazed Screens	61
7.19 Installation and Supporting Construction	62
7.20 Gap Sealing to Door Frames	68
7.21 Perimeter Door Seals	71
8. Conclusion	73

9. Limitations	74
10. Validity	76
11. Declaration by the Applicant	77
Appendix A – Approved Leaf Envelopes and Intumescent Seal Specifications for 44mm Thick Optima FD30 Doors in SOFTWOOD/HARDWOOD Frames	78
Appendix B – Approved Leaf Envelopes and Intumescent Seal Specifications for 44mm Thick Optima FD30 Doors in MDF Frames	122
Appendix C – Approved Leaf Envelopes and Intumescent Seal Specifications for 44mm Thick Optima FD30 Doors in STEEL Frames	125
Appendix D – Approved Leaf Envelopes and Intumescent Seal Specifications for 44mm Thick Optima FD30 Doors in ALUMINIUM Frames	130
Appendix E – Approved Leaf Envelopes and Intumescent Seal Specifications for 44mm Thick BOND-UP FD30 Optima Doors in HARDWOOD Frames	135
Appendix F – Approved Leaf Envelopes and Intumescent Seal Specifications for 44mm Thick PANELLED Optima FD30 Doors in HARDWOOD Frames	140
Appendix G – Approved Hardware Items	145
Appendix H – Summary of Fire Test Evidence	174

1. Introduction

This report has been prepared by Kiwa Fire Safety Compliance (KFS), on the instruction of Halspan Ltd, to define the Field of Application for the Optima FD30 timber door type, comprising timber door leaves installed in timber, steel and aluminium frames, that are required to provide 30 minutes fire resistance performance, when adjudged against BS476: Part 22: 1987.

This assessment has been produced using the principles outlined in the [Passive Fire Protection Forum \(PFPF\): 'Guide to undertaking technical assessments of fire performance of construction products based on fire test evidence, 2021, Industry Standard Procedure'](#).

When establishing the variations in the construction that can achieve the required fire resistance performance, KFS complies with the principles found in the following documents:

- [BS ISO/TR 12470-2: 2017 'Fire resistance tests - Guidance on the application and extension of results from tests conducted on fire containment assemblies and products. Part 2: Non-load bearing elements'](#).
- [EN 15725: 2023: 'Extended application reports on the fire performance of construction products and building elements'](#).

It is proposed that variations to the tested specifications, as described in the following sections, may be accommodated into door assemblies, without reducing their potential to achieve a 30 minute integrity rating, if tested in accordance with the method and criteria of BS476: Part 22: 1987. The omission of information on any components or manufacturing methods does not imply a lack of approval of those details, but these would need to be the subject of a separate analysis. Only variations specifically mentioned are supported by this assessment document, all other aspects must otherwise be as proven in tests summarised herein.

2. Use of this Report

The approved scope detailed herein is specific to the Optima FD30 timber door type and it must not be used either in part, or whole form, to support other door assemblies/ranges/designs.

When the Optima FD30 door type is installed under the scope of this Field of Application Report, a full and complete copy of this document, along with any relevant supporting information, must be submitted to Building Control as part of the approval process, so as to demonstrate compliance with Regulatory guidance (i.e. Building Regulations)

In addition, a copy of this report, along with any relevant supporting information, must be included in the O&M manual and Fire Safety Information Files prior to project completion/building handover.

Assessments, certificates, or scope of approval documents issued by organisations other than KFS must not be used in conjunction with this report or in support of any element of the proposed door assemblies.

3. Fire Test Evidence

3.1 General

Following completion of a fire test, the relevant fire test laboratory will issue a test report to the test sponsor. This document summarises the test specimen construction, the test conditions/data and the test results. It is this test data which KFS evaluate to determine the approved scope detailed within this Field of Application Report.

Approved Document B of the Building Regulations (2019 Edition with 2020 Amendments), the Scottish Building Standards Technical Handbook (2013 Edition) or the Building Regulations (Northern Ireland) 2012 stipulate that all fire resisting door assemblies must have been successfully fire tested in accordance with BS476: Part 22: 1987 or BS EN 1634-1:2014+A1:2018.

The BS476: Part 22: 1987 or BS EN 1634-1:2014+A1:2018 fire test evidence which has been used in support of this Field of Application Report is summarised in Appendix H.

Only the critical details for each fire test report are detailed in Appendix H to ensure that:

- The full details of the fire test reports remain confidential, therefore protecting the intellectual property of the fire test sponsors
- The size/length of this report is kept to a minimum, so that it remains useable

If full copies of the referenced fire test reports are required, then requests for this information should be directed to Halspan Ltd.

3.2 Suitability of Fire Test Evidence

The fire test reports summarised in Appendix H have been reviewed by KFS in accordance with the principles outlined in the Passive Fire Protection Forum (PFPF): 'Guide to undertaking technical assessments of fire performance of construction products based on fire test evidence, 2021, Industry Standard Procedure' to ensure they are original, complete and relevant to the proposed construction/application.

Where fire test reports are more than 5 years old, additional checks have been undertaken by KFS to ensure they remain valid.

The BS EN 1634-1 fire test standard has been revised a number of times since 2000, and the current version is BS EN 1634-1:2014+A1:2018. KFS have concluded that the revisions to this fire test standard would not have had a critical impact on the fire test result, or data, and, as such, fire tests undertaken in accordance with BS EN 1634-1:2000, BS EN 1634-1:2008, BS EN 1634-1:2014 and BS EN 1634-1:2014+A1:2018 have been accepted as supporting evidence for this Field of Application Report.

A number of the fire tests referenced in Appendix H comprised specimens which experienced premature integrity failure. This does not exclude the use of these fire test reports in support of items or details which:

- Did not directly contribute to the failure
- Were remote from the point of failure
- Continued to satisfy the test criteria for the required period of fire resistance

Where premature integrity failures did occur, these are detailed in Appendix H alongside the relevant fire test report/s with additional notes added for clarification.

3.3 Use of BS and EN Test Evidence

The appropriate performance of fire resisting doorsets is defined in Approved Document B of the Building Regulations England (2019 Edition with 2020 Amendments), the Scottish Building Standards Technical Handbook (2019 edition), Approved Document B of the Building Regulations Wales (2006 Edition with 2010, 2013, 2016, 2017 and 2020 Amendments) or the Building Regulations (Northern Ireland) 2012.

Table C1 in Appendix C of Approved Document B, which applies to England, identifies doorsets by their performance under test to BS EN 1634-1 or BS476: Part 22: 1987, in terms of integrity for a period of minutes, (e.g., E30/E60, if their performance is measured in terms of EN 1634-1, or FD30/FD60 for BS476: Part 22: 1987). It should be noted that a suffix (S) is added for doors where restricted smoke leakage at ambient temperatures is needed. The Scottish, Welsh and Northern Ireland documents also refer to the British and European Standards in Section 2D, Table B1 in Appendix B and Section B3 respectively of these documents.

These guidance documents thus give a parity of performance between the two test methods, and although the EN 1634-1 and the BS476: Part 22: 1987 test procedures are both generally based upon the ISO 834 fire resistance test method, there are differences. The major ones are thus;

- a. The method of measuring the furnace (exposure) temperature in the EN 1634-1 test is by means of plate thermocouples. The 'plates' have a greater thermal inertia than the bead thermocouples used in the BS476: Part 22: 1987 test, and therefore the heat input is higher than that given in BS476 at any given time during approximately the first 15 minutes of a fire resistance test.
- b. The furnace pressure in the EN 1634-1 test is neutral at a position 500mm above the threshold, compared to a nominal 1 metre in the BS476: Part 22: 1987 test. As a consequence, the pressure over the upper part of the doorset is higher and, therefore, is more onerous in the EN test.

There are other minor procedural matters that also increase the severity of the EN method. These, combined with the issues identified in a) and b) above, mean that the EN 1634-1 test is generally accepted as being a more onerous test than BS476: Part 22: 1987. This is borne out by KFS's experience of fire resistance testing already performed since the introduction of the European test standard.

As such, it is our opinion that any test results on doorsets tested to EN 1634-1 can be utilised in situations requiring a performance defined against the BS476: Part 22 test method, or when making assessments and judgements against the BS476 criteria, but not vice versa.

3.4 Door Orientation

When undertaking the fire testing of a hinged or pivoted timber door assembly, it is generally considered that the most onerous configuration for the test specimen is with the door leaf/leaves opening in towards the furnace. This is formalised in Section 13.4.2 of BS EN 1634-1: 2014+A1: 2018. Halspan have carried out fire resistance testing with door leaves opening towards and away from the furnace.

Unless stated otherwise herein, where a door configuration/construction has been fire tested with the door leaf/leaves opening in towards the test furnace, the approval within this Field of Application Report permits the door configuration/construction to be installed with the door leaf/leaves opening in the opposite direction (i.e. away from the furnace/risk side).

This principle is only applicable when the door construction, and any features within the door leaf/leaves, such as glazing, are symmetrical. In scenarios where an asymmetrical construction has only been fire tested in one orientation, then this Field of Application Report will limit its use as such, with a clear stipulation on which elements of the construction must be orientated towards the fire risk side of the door assembly.

Although uncommon, the inclusion of certain items/details within a door assembly may mean that the most onerous fire test configuration is one where the door leaf/leaves open away from furnace. In these scenarios, the door construction/configuration must have been fire tested with door leaf/leaves opening away from furnace in order to achieve approval by KFS.

4. Approved Door Assembly Configurations

4.1 General Requirements/Notes

GENERAL REQUIREMENTS/NOTES

- The tables in Section 4.2, provide an overview of the door assembly configurations approved by KFS for use with the Optima FD30 door type
- The approved leaf configurations may be further restricted when specific design details or items are included
- A table is included within each section of this report which details the leaf configuration/s, maximum leaf size, door construction options, frame options and perimeter intumescent seal specifications which are approved with each item/detail. Where the requirements within these tables differ across multiple items/details which are included in the same door assembly then the lowest common denominators must be selected for the proposed configuration (i.e. the smallest leaf size, the greatest intumescent specification etc)
- Unless stated otherwise, herein, this Field of Application Report considers the scope of approval for door assemblies that may be installed in either orientation, that being with either face exposed to fire conditions

4.2 Door Assembly Configurations

4.2.1 44mm Optima FD30 Doors in Softwood/Hardwood Frames

LEAF/OVERPANEL CONFIGURATION	CODE	LEAF ENVELOPE
	<ul style="list-style-type: none"> • Latched • Single Acting • Single Door 	LSASD A01
	<ul style="list-style-type: none"> • Unlatched • Single Acting • Single Door 	ULSASD A02
	<ul style="list-style-type: none"> • Unlatched • Double Acting • Single Door 	DASD A03
	<ul style="list-style-type: none"> • Latched • Single Acting • Double Door 	LSADD A04
	<ul style="list-style-type: none"> • Unlatched • Single Acting • Double Door 	ULSADD A05
	<ul style="list-style-type: none"> • Unlatched • Double Acting • Double Door 	DADD A06
	<ul style="list-style-type: none"> • Latched • Single Acting • Single Door • With Transomed Overpanel 	LSASD.OP A07
	<ul style="list-style-type: none"> • Latched • Single Acting • Single Door • With Square/Rebated Overpanel 	LSASD.OP A08
	<ul style="list-style-type: none"> • Unlatched • Single Acting • Single Door • With Transomed Overpanel 	ULSASD.OP A09

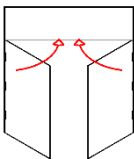
LEAF/OVERPANEL CONFIGURATION	CODE	LEAF ENVELOPE
	<ul style="list-style-type: none"> • Unlatched • Single Acting • Single Door • With Square/Rebated Overpanel 	<p>ULSASD.OP A10</p>
	<ul style="list-style-type: none"> • Latched • Single Acting • Double Door • With Transomed Overpanel 	<p>LSADD.OP A11</p>
	<ul style="list-style-type: none"> • Latched • Single Acting • Double Door • With Square/Rebated Overpanel 	<p>LSADD.OP A12</p>
	<ul style="list-style-type: none"> • Unlatched • Single Acting • Double Door • With Transomed Overpanel 	<p>ULSADD.OP A13</p>
	<ul style="list-style-type: none"> • Unlatched • Single Acting • Double Door • With Square/Rebated Overpanel 	<p>ULSADD.OP A14</p>
	<ul style="list-style-type: none"> • Double Acting • Double Door • With Square/Rebated Overpanel 	<p>DADD.OP A15</p>
	<ul style="list-style-type: none"> • Double Acting • Double Door • With Transomed Overpanel 	<p>DADD.OP A16</p>

4.2.2 44mm Optima FD30 Doors in MDF Frames

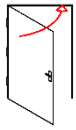
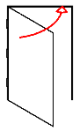
LEAF/OVERPANEL CONFIGURATION		CODE	LEAF ENVELOPE
	<ul style="list-style-type: none"> • Latched • Single Acting • Single Door 	LSASD	B01
	<ul style="list-style-type: none"> • Unlatched • Single Acting • Single Door 	ULSASD	B02

4.2.3 44mm Optima FD30 Doors in Steel Frames

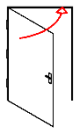
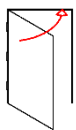
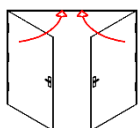
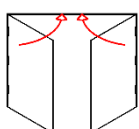
LEAF/OVERPANEL CONFIGURATION		CODE	LEAF ENVELOPE
	<ul style="list-style-type: none"> • Latched • Single Acting • Single Door 	LSASD	C01
	<ul style="list-style-type: none"> • Unlatched • Single Acting • Single Door 	ULSASD	C02
	<ul style="list-style-type: none"> • Latched • Single Acting • Double Door 	LSADD	C03
	<ul style="list-style-type: none"> • Unlatched • Single Acting • Double Door 	ULSADD	C04

4.2.4 44mm Optima FD30 Doors in Aluminium Frames

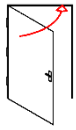
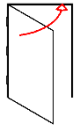
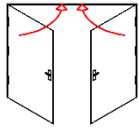
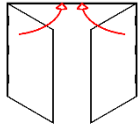
LEAF/OVERPANEL CONFIGURATION	CODE	LEAF ENVELOPE
	<ul style="list-style-type: none"> • Latched • Single Acting • Single Door 	<p>LSASD D01</p>
	<ul style="list-style-type: none"> • Unlatched • Single Acting • Single Door 	<p>ULSASD D02</p>
	<ul style="list-style-type: none"> • Latched • Single Acting • Double Door 	<p>LSADD D03</p>
	<ul style="list-style-type: none"> • Unlatched • Single Acting • Double Door 	<p>ULSADD D04</p>

4.2.5 44mm Optima Bond-Up FD30 Doors in Softwood Frames

This door leaf construction type and frame combination is not approved in this report.

4.2.6 44mm Optima Bond-Up FD30 Doors in Hardwood Frames

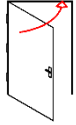
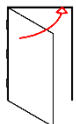
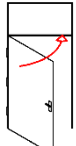
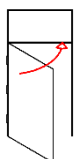
LEAF/OVERPANEL CONFIGURATION	CODE	LEAF ENVELOPE
	<ul style="list-style-type: none"> Latched Single Acting Single Door 	<p>LSASD E01</p>
	<ul style="list-style-type: none"> Unlatched Single Acting Single Door 	<p>ULSASD E02</p>
	<ul style="list-style-type: none"> Latched Single Acting Single Door With Transomed Overpanel 	<p>LSASD.OP E03</p>
	<ul style="list-style-type: none"> Unlatched Single Acting Single Door With Transomed Overpanel 	<p>ULSASD.OP E04</p>

4.2.7 44mm Optima Bond-Up FD30 Doors in MDF Frames

This door leaf construction type and frame combination is not approved in this report.

4.2.8 44mm Optima Bond-Up FD30 Doors in Steel Frames

This door leaf construction type and frame combination is not approved in this report.

4.2.9 44mm Optima Bond-Up FD30 Doors in Aluminium Frames

This door leaf construction type and frame combination is not approved in this report.

4.2.10 44mm Optima Panelled FD30 Doors in Softwood Frames

This door leaf construction type and frame combination is not approved in this report.

4.2.11 44mm Optima Panelled FD30 Doors in Hardwood Frames

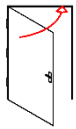
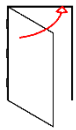
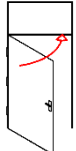
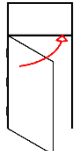
LEAF/OVERPANEL CONFIGURATION	CODE	LEAF ENVELOPE
	<ul style="list-style-type: none"> • Latched • Single Acting • Single Door 	<p>LSASD</p> <p>F01</p>
	<ul style="list-style-type: none"> • Unlatched • Single Acting • Single Door 	<p>ULSASD</p> <p>F02</p>
	<ul style="list-style-type: none"> • Latched • Single Acting • Single Door • With Transomed Overpanel 	<p>LSASD.OP</p> <p>F03</p>
	<ul style="list-style-type: none"> • Unlatched • Single Acting • Single Door • With Transomed Overpanel 	<p>ULSASD.OP</p> <p>F04</p>

4.2.12 44mm Optima Panelled FD30 Doors in MDF Frames

This door leaf construction type and frame combination is not approved in this report.

4.2.13 44mm Optima Panelled FD30 Doors in Steel Frames

This door leaf construction type and frame combination is not approved in this report.

4.2.14 44mm Optima Panelled FD30 Doors in Aluminium Frames

This door leaf construction type and frame combination is not approved in this report.

5. Maximum Assessable Door Leaf Sizes

The calculated envelopes of assessed leaf dimensions for each door assembly configuration covered by this Field of Application report are given in Appendices A to F.

Double door assemblies may each be of the same width, up to the maximum width indicated in Appendix A or B. For unequal pairs there is no limit on the ratio of leaf widths, (although the large leaf must still be within the limitations in Appendices A to F. The width of the small leaf shall not be less than 250mm, since this will affect its vertical stability relative to that of the larger leaf.

6. Hardware

Hardware items which are approved for use with the Optima FD30 timber door assemblies are detailed in Appendix G of this report.

All hardware items must be installed in accordance with the manufacturer's instructions, except where specific installation requirements or limitations have been detailed by KFS.

7. Optima FD30 Constructional Details

7.1 General Requirements

ELEMENT	SPECIFICATION/QUANTITY/DIMENSIONS		
GENERAL	The constructional details, specified herein, are based upon the details contained within the fire test evidence referenced in Appendix H, and define variations and tolerances, where KFS consider that these will not adversely affect the intended fire resistance performance. The construction details are limited to the information available from the fire test reports		
TIMBER	<p>All timber used in the manufacture/construction of the proposed timber door assemblies must meet the following requirements:</p> <ol style="list-style-type: none"> 1. Must achieve the stated minimum densities when measured at 9-12% moisture content 2. The timber must be straight grained and of appropriate quality in accordance with BS EN 942: 2007 3. The moisture content must be $11 \pm 2\%$ for the UK market, or to suit internal joinery moisture content specification of export countries 		
ADHESIVES	All adhesives must be applied in a continuous bed, covering the entire surface area of the leaf face or leaf edge, as applicable. Unless specifically noted otherwise, this report does <i>not</i> permit the use of spot bonding		
	<table border="1" style="width: 100%; border-collapse: collapse;"> <tr> <td style="width: 15%; text-align: center;">PU</td> <td>Polyurethane</td> </tr> </table>	PU	Polyurethane
	PU	Polyurethane	
	<table border="1" style="width: 100%; border-collapse: collapse;"> <tr> <td style="width: 15%; text-align: center;">PUR</td> <td>Polyurethane based hotmelt adhesives must have been successfully fire tested in accordance with BS476: Part22:1987 or BS EN 1634-1 for 30 minutes</td> </tr> </table>	PUR	Polyurethane based hotmelt adhesives must have been successfully fire tested in accordance with BS476: Part22:1987 or BS EN 1634-1 for 30 minutes
	PUR	Polyurethane based hotmelt adhesives must have been successfully fire tested in accordance with BS476: Part22:1987 or BS EN 1634-1 for 30 minutes	
	<table border="1" style="width: 100%; border-collapse: collapse;"> <tr> <td style="width: 15%; text-align: center;">RF</td> <td>Resorcinol Formaldehyde</td> </tr> </table>	RF	Resorcinol Formaldehyde
	RF	Resorcinol Formaldehyde	
<table border="1" style="width: 100%; border-collapse: collapse;"> <tr> <td style="width: 15%; text-align: center;">UF</td> <td>Urea Formaldehyde</td> </tr> </table>	UF	Urea Formaldehyde	
UF	Urea Formaldehyde		
<table border="1" style="width: 100%; border-collapse: collapse;"> <tr> <td style="width: 15%; text-align: center;">PF</td> <td>Phenol Formaldehyde</td> </tr> </table>	PF	Phenol Formaldehyde	
PF	Phenol Formaldehyde		
<table border="1" style="width: 100%; border-collapse: collapse;"> <tr> <td style="width: 15%; text-align: center;">PVA/PVAc</td> <td>Polyvinyl Acetate</td> </tr> </table>	PVA/PVAc	Polyvinyl Acetate	
PVA/PVAc	Polyvinyl Acetate		
<p><i>Note</i> The list above provides clarification on the abbreviated terms for common glue types, but not all these types may be approved. For glue types approved for use with the proposed timber door assemblies, refer to Section 7</p>			
DOOR LEAF SHAPE	This report only approves doors that are rectilinear, i.e. adjacent door edges shall be straight, and at 90 degrees to each other, when viewed in elevation. In addition, doors shall be “flat”; i.e. not curved, when viewed in plan		
ADDITIONAL NOTES/REQUIREMENTS	Alternative materials/components to those approved herein, must not be used without prior consultation with KFS, regardless of how similar they may appear in terms of specification		

7.2 Leaf and Overpanel Construction

7.2.1 Leaf and Overpanel Construction - 44mm Optima FD30

7.2.1.1 Finished Leaf and Overpanel Thickness

ELEMENT	SPECIFICATION/QUANTITY/DIMENSIONS
MINIMUM LEAF THICKNESS	43mm (Prior to the application of decorative leaf facings or finishes and/or calibration)
MAXIMUM LEAF THICKNESS	Refer to permitted decorative leaf facings and finishes detailed in Sections 7.5 and 7.6, respectively
ADDITIONAL NOTES/REQUIREMENTS	A maximum of 0.5mm of material may be removed from each face of the 44mm thick door blank for calibration purposes

7.2.1.2 Leaf and Overpanel Core Material

ELEMENT	SPECIFICATION/QUANTITY/DIMENSIONS
CORE MATERIAL	Particleboard
MINIMUM THICKNESS	44mm (prior to calibration – refer to 7.2.1.1)
MINIMUM DENSITY	630kg/m ³ ±10%
ADDITIONAL NOTES/REQUIREMENTS	Jointing of the particleboard core is not permitted

7.2.1.3 Structural Sub-Facings

Structural sub-facings are ***not*** permitted under the scope of this Field of Application Report

7.2.1.4 Structural Leaf Facings

Structural leaf facings are ***not*** permitted under the scope of this Field of Application Report

7.2.1.5 Stiles and Rails

Stiles and rails are ***not*** permitted under the scope of this Field of Application Report

7.2.2 Leaf and Overpanel Construction – 44mm Thick Optima FD30 Bond-Up

7.2.2.1 Finished Leaf and Overpanel Thickness

ELEMENT	SPECIFICATION/QUANTITY/DIMENSIONS
MINIMUM LEAF THICKNESS	43mm (Prior to the application of decorative leaf facings or finishes)
MAXIMUM LEAF THICKNESS	Refer to permitted decorative leaf facings and finishes detailed in Sections 7.5 and 7.6, respectively
ADDITIONAL NOTES/REQUIREMENTS	A maximum of 0.5mm of material may be removed from each face of the 44mm thick door for calibration purposes

7.2.2.2 Leaf and Overpanel Core Material

ELEMENT	SPECIFICATION/QUANTITY/DIMENSIONS
CORE MATERIAL	Particleboard
THICKNESS	38mm (prior to calibration – refer to 7.2.2.1)
MINIMUM DENSITY	630kg/m ³ ±10%
ADDITIONAL NOTES/REQUIREMENTS	Jointing of the particleboard core is not permitted

7.2.2.3 Structural Sub-Facings

Structural sub-facings are ***not*** permitted under the scope of this Field of Application Report

7.2.2.4 Structural Leaf Facings

ELEMENT	SPECIFICATION/QUANTITY/DIMENSIONS
STRUCTURAL LEAF FACING OPTIONS	Hardwood plywood (Minimum density 750kg/m ³) MDF (Minimum density 750kg/m ³)
STRUCTURAL LEAF FACING THICKNESS	3mm facing applied to a 38mm thick blank
LEAF FACING ADHESIVE	Urea Formaldehyde
ADDITIONAL REQUIREMENTS/NOTES	A single structural leaf facing of the same material and thickness must be applied to each side of the core material detailed in Section 7.2.2.2.

7.2.2.5 Stiles and Rails

Stiles and rails are ***not*** permitted under the scope of this Field of Application Report

7.2.3 Leaf and Overpanel Construction – 44mm Thick Optima FD30 Panelled

7.2.3.1 Finished Leaf and Overpanel Thickness

ELEMENT	SPECIFICATION/QUANTITY/DIMENSIONS
MINIMUM LEAF THICKNESS	44mm (Prior to the application of decorative leaf facings or finishes)
MAXIMUM LEAF THICKNESS	Refer to permitted decorative leaf facings and finishes detailed in Sections 7.5 and 7.6, respectively
ADDITIONAL NOTES/REQUIREMENTS	A maximum of 0.5mm of material may be removed from each face of the 44mm thick door for calibration purposes

7.2.3.2 Leaf and Overpanel Core Material

ELEMENT	SPECIFICATION/QUANTITY/DIMENSIONS
CORE MATERIAL	Particleboard
THICKNESS	44mm (prior to calibration – refer to 7.2.2.1) Reduced to 20mm thick at panel areas
PANEL FACING MATERIAL	3mm thick MDF
ADHESIVE	PANEL FACING Urea formaldehyde
MINIMUM DENSITY	CORE 630kg/m ³ ±10%
	FACINGS 700kg/m ³
ADDITIONAL NOTES/REQUIREMENTS	Jointing of the particleboard core is not permitted

7.2.3.3 Panel Beading

ELEMENT	SPECIFICATION/QUANTITY/DIMENSIONS
MATERIAL	Hardwood
DENSITY	Minimum 640kg/m ³
DIMENSIONS	19.5mm high x 15mm deep including 5mm x 5mm deep bolection return and 25 degree chamfer
FIXINGS	40mm long 1.6mm thick panel pins at 150mm centres at 25deg to the face of the panel

7.3 Door Lippings

7.3.1 Timber Door Lippings – General

ELEMENT	SPECIFICATION/QUANTITY/DIMENSIONS
LIPPING THICKNESS	Refer to Section 7.3.2
LIPPING PROFILES	
LIPPING MATERIAL	Hardwood – Not Beech (Minimum density 640kg/m ³)
LIPPING ADHESIVE OPTIONS	Option 1 Resorcinol Formaldehyde
	Option 2 Urea Formaldehyde
	Option 3 Polyurethane
	Option 4 Polyurethane based hotmelt adhesives as must have been successfully fire tested in accordance with BS476: Part:1987 or BS EN 1634-1 for 30 minutes
ADDITIONAL REQUIREMENTS/NOTES	<ul style="list-style-type: none"> • Lippings must be installed to both vertical leaf edges • Lippings must be applied after the bonding of structural leaf faces (where applicable) • Lippings may also be applied to the top and/or bottom leaf edges, if required • Installed lippings may be reduced in thickness for site installation purposes, provided the minimum lipping thickness detailed in Section 7.3.2 is maintained • There must be no gaps present between the core and lippings • If hardware items are morticed in the leaf head, then a hardwood lipping would be required

7.3.2 Timber Door Lippings – Lipping Thickness and Edge Profiles

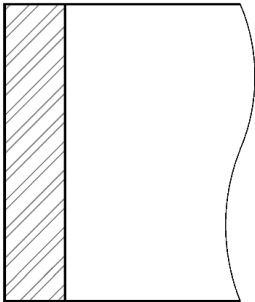
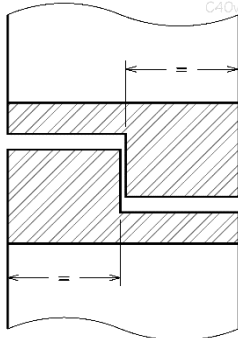
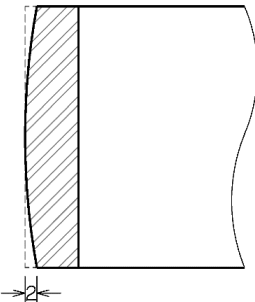
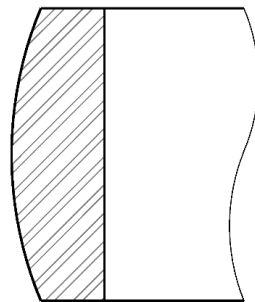
EDGE TYPE L30/1 – SQUARE			EDGE TYPE L30/2 –REBATE		
					
PERMITTED LIPPING LOCATION			PERMITTED LIPPING LOCATION		
All door leaf and overpanel edges (if applicable)			Interface between leaf head and flush overpanel and rebated meeting stiles		
LIPPING THICKNESS AND FRAME OPTIONS			LIPPING THICKNESS AND FRAME OPTIONS		
Timber	Steel	Aluminium	Timber	Steel	Aluminium
8-12mm	8-12mm	10-12mm	18-22mm	N/A	N/A
ADDITIONAL REQUIREMENTS/NOTES			ADDITIONAL REQUIREMENTS/NOTES		
None			<p>10-12mm deep rebate</p> <p>Rebate may be equal or unequal but shall be of a size where the required intumescent seals can be fitted in the rebates. See Appendices A to F, as applicable</p> <p>Hardware is not permitted to be installed in the location of a rebated leaf head/overpanel interface</p>		
EDGE TYPE L30/3 – SHALLOW RADIUS			EDGE TYPE L30/4 – RADIUS PIVOT		
					
PERMITTED LIPPING LOCATION			PERMITTED LIPPING LOCATION		
<ul style="list-style-type: none"> Closing edge of double acting doors Meeting stiles of double doors 			Hanging edge of double acting doors (Scalloped frame profile F30/4 only)		
LIPPING THICKNESS AND FRAME OPTIONS			LIPPING THICKNESS AND FRAME OPTIONS		
Timber	Steel	Aluminium	Timber	Steel	Aluminium
8-12mm	N/A	N/A	10-20mm	N/A	N/A
ADDITIONAL REQUIREMENTS/NOTES			ADDITIONAL REQUIREMENTS/NOTES		
The radius shall not remove more than 2mm thickness of lippings on the door face			Radius to suit the pivot/floor spring employed		

EDGE TYPE L30/5 – RADIUS MEETING STILE

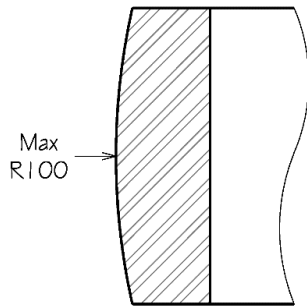

PERMITTED LIPPING LOCATION

Meeting stiles of double acting doors

LIPPING THICKNESS AND FRAME OPTIONS

Timber	Steel	Aluminium
8-12mm	N/A	N/A

ADDITIONAL REQUIREMENTS/NOTES

Minimum Radius of 60mm as tested in WARRES 135011.

EDGE TYPE L30/6 – 12MM RADIUS CORNERS

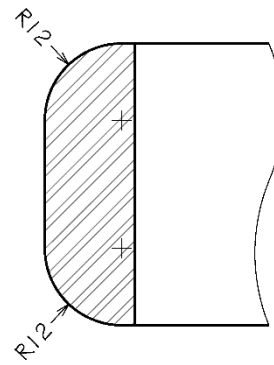

LIPPING LOCATION

Hanging edges of PVC encapsulated doors

This edge profile is not permitted under the scope of this Field of Application Report

EDGE TYPE L30/7 – 6MM RADIUS CORNERS

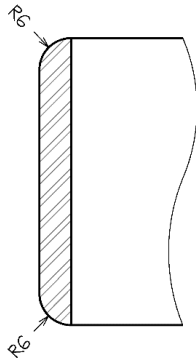

PERMITTED LIPPING LOCATION

- Closing edge of double acting doors only

LIPPING THICKNESS AND FRAME OPTIONS

Timber	Steel	Aluminium
10-12mm	N/A	N/A

ADDITIONAL REQUIREMENTS/NOTES

None

EDGE TYPE L30/8 – MAXIMUM 2.5 DEGREE CLOSING LEAF EDGE

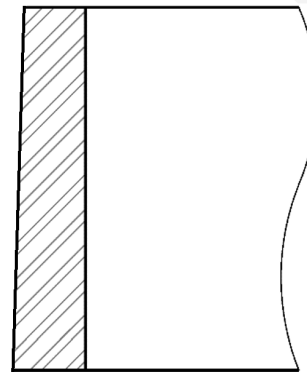

PERMITTED LIPPING LOCATION

- Closing edge of single acting single leaves only

LIPPING THICKNESS AND FRAME OPTIONS

Timber	Steel	Aluminium
10-12mm	N/A	N/A

ADDITIONAL REQUIREMENTS/NOTES

Minimum lipping thickness of 10mm must be maintained at the chamfer location. In all cases, the gap around the leaf edge(s) must be in accordance with Section 7.19.11

7.3.3 Edgebanding

ELEMENT	SPECIFICATION/QUANTITY/DIMENSIONS
LIPPING THICKNESS	2mm
LIPPING PROFILES	Square L30/1
MATERIAL	PVC
MINIMUM DENSITY	-
LIPPING ADHESIVE	Dorus US241/4 natur
ADDITIONAL REQUIREMENTS/NOTES	<ul style="list-style-type: none"> • Edge-banding must be installed to all leaf edges • There must be no gaps present between the core and the edge-banding • Only lipping type L30/1 is permitted to be used with edgebanding, but with a maximum thickness of 2mm as stated above • In all cases, the gap around the leaf edge(s) must be in accordance with Section 7.19.11 • When used at the meeting edges of double doors the following intumescent specification shall be used: <ul style="list-style-type: none"> • 2no 10 x 4mm positioned in active leaf edge spaced 20mm apart AND 1no. 15 x 4mm in passive leaf edge fitted centrally • Concealed hardware, such as closers and hinges are not permitted with edgebanding • Floor springs are not permitted with edgebanding • Hardware Sections G.1 & G.5 are permitted. • For use with timber frames only • Not permitted for use with flush or rebated overpanel junctions. • Must be used with latched single acting door assemblies.
FIRE RESISTANCE TEST DATA	RF08039

7.4 PVC Encapsulated Doors

PVC encapsulated doors are ***not*** permitted under the scope of this Field of Application Report

7.5 Decorative Leaf Facings

ELEMENT	SPECIFICATION/QUANTITY/DIMENSIONS			
PERMITTED APPLICATION AREA	Leaf faces only			
DECORATIVE LEAF FACING OPTIONS	Option 1	Timber veneer	Option 4	Cellulosic foil
	Option 2	High Pressure Laminate (HPL)	Option 5	Paper
	Option 3	PVC	Option 6	Vinyl
MAXIMUM LEAF FACING THICKNESS	2mm			
LEAF FACING ADHESIVE OPTIONS	Option 1	Polyurethane	Option 4	PVA
	Option 2	Resorcinol Formaldehyde	Option 5	Contact adhesive
	Option 3	Urea Formaldehyde		
ADDITIONAL REQUIREMENTS/NOTES	<ul style="list-style-type: none"> All decorative leaf facings must be surface applied and must not be recessed into the door leaf face. However, decorative leaf facings may be applied following calibration (refer to Section 7.2) Decorative leaf facings are <u>not</u> permitted to return around the leaf edges With the exception of the push/kick plates detailed in Appendix I, metallic facings are not permitted 			

DOOR CONFIGURATIONS				MAXIMUM LEAF SIZE	DOOR CONSTRUCTION	
LSASD	✓	LSADD	✓	Refer to the relevant Figure in Appendix A to F, as applicable for the proposed door configuration	44mm Optima	✓
ULSASD	✓	ULSADD	✓		44mm Optima Bond-Up	✓
DASD	✓	DADD	✓		44mm Optima Panelled	✓
LSASD+OP	✓	LSADD+OP	✓			
ULSASD+OP	✓	ULSADD+OP	✓		FRAME CONSTRUCTION	
DASD+OP	✓	DADD+OP	✓		Timber Frame	✓
					Steel Frame	✓
PERIMETER INTUMESCENT SEAL SPECIFICATION					Aluminium Frame	✓
Refer to the relevant Figure in Appendix A to F, as applicable for the proposed door configuration						

7.6 Decorative Leaf Finishes

ELEMENT	SPECIFICATION/QUANTITY/DIMENSIONS			
PERMITTED APPLICATION AREA	Leaf faces and leaf edges			
DECORATIVE LEAF FINISH OPTIONS	Option 1	Paint	Option 4	Stain
	Option 2	Lacquer	Option 5	Grain filler/Epoxy Resin
	Option 3	Varnish		
MAXIMUM LEAF FINISH THICKNESS	0.5mm, or a maximum of 5 coats, whichever is greater, per leaf face			
ADDITIONAL REQUIREMENTS/NOTES	Intumescent coatings are not permitted			

DOOR CONFIGURATIONS				MAXIMUM LEAF SIZE	DOOR CONSTRUCTION	
LSASD	✓	LSADD	✓	Refer to the relevant Figure in Appendix A to F, as applicable for the proposed door configuration	44mm Optima	✓
ULSASD	✓	ULSADD	✓		44mm Optima Bond-Up	✓
DASD	✓	DADD	✓		44mm Optima Panelled	✓
LSASD+OP	✓	LSADD+OP	✓			
ULSASD+OP	✓	ULSADD+OP	✓			
DASD+OP	✓	DADD+OP	✓			
					FRAME CONSTRUCTION	
					Timber Frame	✓
					Steel Frame	✓
					Aluminium Frame	✓
PERIMETER INTUMESCENT SEAL SPECIFICATION						
Refer to the relevant Figure in Appendix A to F, as applicable for the proposed door configuration						

7.7 Decorative Timber Mouldings

7.7.1 Surface Applied Timber Mouldings

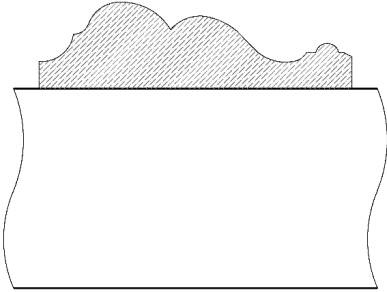
DIAGRAM	
	
<i>FIGURE IS TYPICAL ONLY AND DESIGN MAY VARY</i>	
ELEMENT	SPECIFICATION/QUANTITY/DIMENSIONS
MOULDING MATERIAL OPTIONS	Option 1 Softwood
	Option 2 Hardwood
	Option 3 MDF
MAXIMUM MOULDING SIZE	No limitation but the timber mouldings must not increase the mass of the door leaf by more than 25%
MOULDING POSITION	May be surface applied to one or both faces of the door leaf
ADDITIONAL REQUIREMENTS/NOTES	<ul style="list-style-type: none"> The moulding profile detailed above is indicative and alternative profiles may be used provided they meet the requirements outlined herein Timber mouldings must not return around the leaf edges or oversail glazing beads It is a limitation of the assessment that the timber mouldings must not unbalance the door leaf in-service, in order that the door leaf installation/alignment remains in accordance with the parameters in Section 7.19.11

DOOR CONFIGURATIONS				MAXIMUM LEAF SIZE	DOOR CONSTRUCTION	
LSASD	✓	LSADD	✓	Refer to the relevant Figure in Appendix A to F, as applicable for the proposed door configuration	44mm Optima	✓
ULSASD	✓	ULSADD	✓		44mm Optima Bond-Up	✓
DASD	✓	DADD	✓		44mm Optima Panelled	✓
LSASD+OP	✓	LSADD+OP	✓		FRAME CONSTRUCTION	
ULSASD+OP	✓	ULSADD+OP	✓			
DASD+OP	✓	DADD+OP	✓			
					Timber Frame	✓
					Steel Frame	✓
					Aluminium Frame	✓
PERIMETER INTUMESCENT SEAL SPECIFICATION						
Refer to the relevant Figure in Appendix A to F, as applicable for the proposed door configuration						

7.7.2 Recessed Timber Mouldings

Recessed timber mouldings are ***not*** permitted under the scope of this Field of Application Report

7.8 Feature Grooves

ELEMENT	SPECIFICATION/QUANTITY/DIMENSIONS		
MAXIMUM SIZE	Feature Groove	15mm wide x 8mm deep	
GROOVE INFILL/PROFILE	<ul style="list-style-type: none"> Each groove shall include a hardwood – excluding beech (minimum density 640kg/m³) timber infill. The infill shall be set in place using a non-thermally softening adhesive. Feature grooves may be made in the timber infill up to maximum 5mm wide x 5mm deep. 		
GROOVE ORIENTATION/SPACING	<ul style="list-style-type: none"> Grooves may be orientated vertically and horizontally Grooves must be located a minimum 125mm apart 		
MINIMUM DISTANCE TO LEAF EDGE	Top	Sides	Bottom
	115mm	115mm	115mm
MINIMUM DISTANCE TO GLAZED APERTURE	115mm		
MINIMUM DISTANCE TO HARDWARE	<ul style="list-style-type: none"> Grooves are not permitted to be used with concealed hardware such as hinges or closers, Grooves must not run behind the escutcheon of locks/latches 		
ADDITIONAL DESIGN DETAILS	<ul style="list-style-type: none"> In line with the minimum distance to leaf edge requirements stated above, neither vertical or horizontal feature grooves are permitted to run to the leaf edge. Grooves are permitted on single doors only. Grooves are permitted in the bond-up door construction type only Grooves are permitted when leaves are installed in timber frames only 		
FIRE TEST EVIDENCE	WF412654		

7.9 Recessed Panels

Recessed panels may be incorporated into the design of door assemblies when the leaves are constructed in accordance with Section 7.2.3. Bond up doors are not permitted with recessed panels.

- The maximum permitted dimensions of a single panel is 968mm high x 270mm wide
- Multiple panelled areas are permitted but shall be located such that vertical edges are 117mm away from other panels or 92mm from the vertical leaf edge. Horizontal edges shall be a minimum of 150mm from other panels or 98mm from horizontal leaf edges.
- When a latch is fitted in a panelled door the full thickness stile at the leading edge of the leaf shall be a minimum of 70mm wider than the latch rebate width.
- Concealed closers are not permitted to be used with Recessed panels.
- Bond up door types are not permitted with recessed panels.

7.10 Door Edge Protection

Door edge protection items are not permitted under the scope of this Field of Application Report

7.11 Overpanels

7.11.1 Overpanel Size, Configuration and Specification

ELEMENT	SPECIFICATION/QUANTITY/DIMENSIONS	
MATERIAL	Overpanels must be of the same construction as the door leaf and must be manufactured in a single piece – refer to Section 7.2	
OVERPANEL HEIGHT	Single Door Assemblies	Maximum 2000mm high
	Double Door Assemblies	Maximum 1500mm high
OVERPANEL WIDTH	Overpanels must be sized to fit tightly to the door frame/transom with a maximum 1mm fitting tolerance at all edges	
OVERPANEL CONFIGURATIONS	Refer to Sections 7.11.2, 7.11.3 and 7.11.4	
OVERPANEL QUIRK	A maximum 3x3mm quirk may be machined directly into the perimeter of each transomed overpanel face (adjacent to the door frame)	
ADDITIONAL REQUIREMENTS/NOTES	MDF Frames, Steel Frames, Aluminium Frames are not permitted with overpanels	

7.11.2 Flush Overpanels – Square Interface

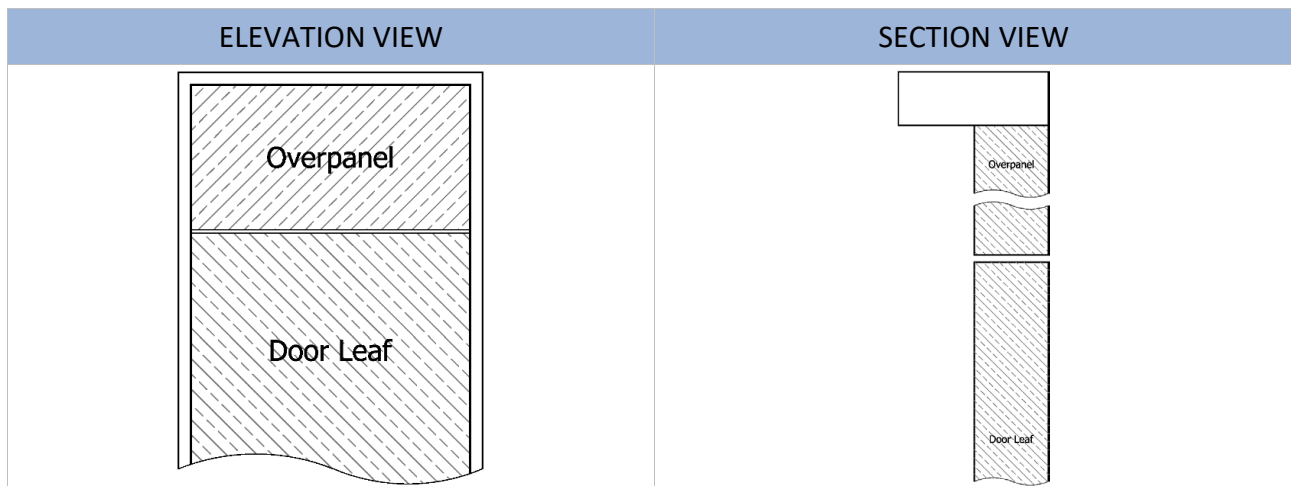

DOOR CONFIGURATIONS				MAXIMUM LEAF SIZE	DOOR CONSTRUCTION	
LSASD	N/A	LSADD	N/A	Refer to relevant figure in Appendix A for the proposed door configuration	44mm Optima	✓
ULSASD	N/A	ULSADD	N/A		44mm Optima Bond-Up	N/A
DASD	N/A	DADD	N/A		44mm Optima Panelled	N/A
LSASD+OP	✓	LSADD+OP	✓		FRAME CONSTRUCTION	
ULSASD+OP	✓	ULSADD+OP	✓			
DASD+OP	✓	DADD+OP	✓			
						Timber Frame (excluding MDF)
					Steel Frame	N/A
					Aluminium Frame	N/A
PERIMETER INTUMESCENT SEAL SPECIFICATION						
Refer to relevant figures in Appendix A for specific intumescent seal specifications						

7.11.3 Flush Overpanels – Rebate Interface

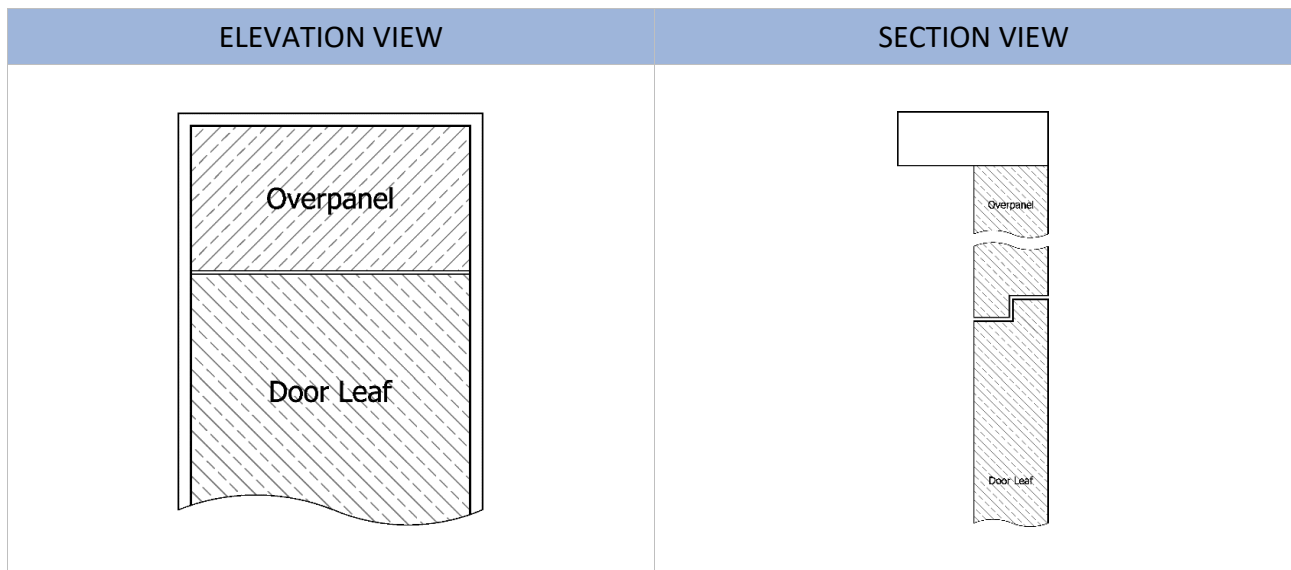

DOOR CONFIGURATIONS				MAXIMUM LEAF SIZE	DOOR CONSTRUCTION									
LSASD	N/A	LSADD	N/A	Refer to relevant figure in Appendix A for the proposed door configuration	44mm Optima	✓								
ULSASD	N/A	ULSADD	N/A		44mm Optima Bond-Up	N/A								
DASD	N/A	DADD	N/A		44mm Optima Panelled	N/A								
LSASD+OP	✓	LSADD+OP	✓		<table border="1" style="width: 100%; border-collapse: collapse;"> <thead> <tr style="background-color: #4a7ebb; color: white;"> <th colspan="2" style="text-align: center;">FRAME CONSTRUCTION</th> </tr> </thead> <tbody> <tr> <td style="text-align: center;">Timber Frame (excluding MDF)</td> <td style="text-align: center;">✓</td> </tr> <tr> <td style="text-align: center;">Steel Frame</td> <td style="text-align: center;">N/A</td> </tr> <tr> <td style="text-align: center;">Aluminium Frame</td> <td style="text-align: center;">N/A</td> </tr> </tbody> </table>		FRAME CONSTRUCTION		Timber Frame (excluding MDF)	✓	Steel Frame	N/A	Aluminium Frame	N/A
FRAME CONSTRUCTION														
Timber Frame (excluding MDF)	✓													
Steel Frame	N/A													
Aluminium Frame	N/A													
ULSASD+OP	✓	ULSADD+OP	✓											
DASD+OP	N/A	DADD+OP	N/A											
PERIMETER INTUMESCENT SEAL SPECIFICATION														
Refer to relevant figures in Appendix A for specific intumescent seal specifications														

7.11.4 Transomed Overpanels

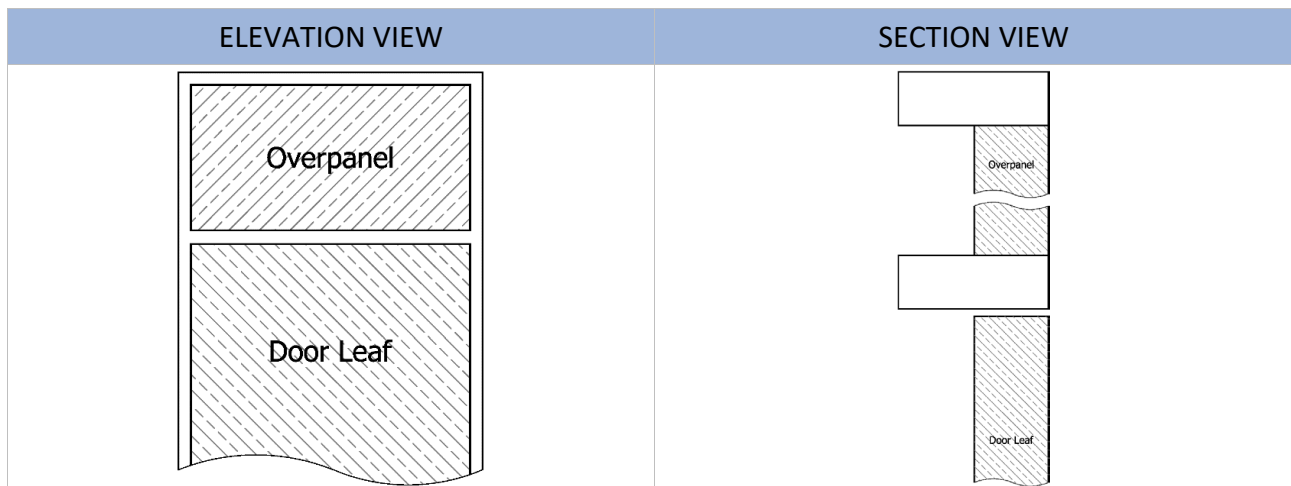

ELEMENT	SPECIFICATION/QUANTITY/DIMENSIONS	
TRANSOM MATERIAL	Single Acting Configurations	<ul style="list-style-type: none"> 70mm wide x 32mm thick section Hardwood – Not Beech (Minimum Density 640kg/m³)
	Double Acting Configurations	<ul style="list-style-type: none"> 95mm wide x 50mm thick section Hardwood – Not Beech (Minimum Density 640kg/m³)
TRANSOM JOINT	Mortice and tenon	
ADDITIONAL REQUIRMENTS/NOTES	The Optima double acting door assemblies must be fitted centrally in the frame width, to ensure a wiping frame is utilised	

DOOR CONFIGURATIONS				MAXIMUM LEAF SIZE	DOOR CONSTRUCTION	
LSASD	N/A	LSADD	N/A	Refer to relevant figure in Appendix A and E, as applicable for the proposed door configuration	44mm Optima	✓
ULSASD	N/A	ULSADD	N/A		44mm Optima Bond-Up (Single Acting Only)	✓
DASD	N/A	DADD	N/A		44mm Optima Panelled	N/A
LSASD+OP	✓	LSADD+OP	✓			
ULSASD+OP	✓	ULSADD+OP	✓			
DASD+OP	✓	DADD+OP	✓			
FRAME CONSTRUCTION						
					Timber Frame (excluding MDF)	✓
					Steel Frame	N/A
					Aluminium Frame	N/A
PERIMETER INTUMESCENT SEAL SPECIFICATION						
Refer to relevant figures in Appendix A and E for specific intumescent seal specifications						

7.11.5 Transomed Overpanels – Individual Frames

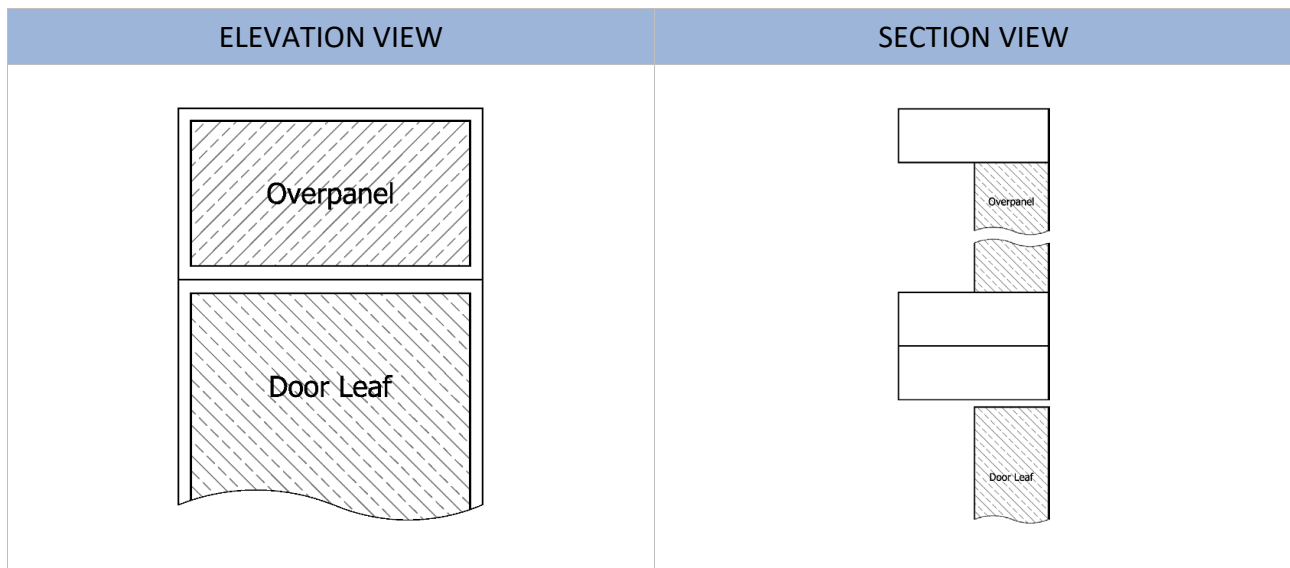

ELEMENT	SPECIFICATION/QUANTITY/DIMENSIONS	
TRANSOM MATERIAL	Single Acting Configurations	<ul style="list-style-type: none"> 70mm wide x 32mm thick each section Hardwood – Not Beech (Minimum Density 640kg/m³)
	Double Acting Configurations	<ul style="list-style-type: none"> 95mm wide x 32mm thick each section Hardwood – Not Beech (Minimum Density 640kg/m³)
TRANSOM JOINT	Mortice and tenon	
ADDITIONAL REQUIRMENTS/NOTES	The Optima double acting door assemblies must be fitted centrally in the frame width, with a wiping frame utilised	

DOOR CONFIGURATIONS				MAXIMUM LEAF SIZE	DOOR CONSTRUCTION	
LSASD	N/A	LSADD	N/A	Refer to relevant figure in Appendix A, E and F, as applicable for the proposed door configuration	44mm Optima	✓
ULSASD	N/A	ULSADD	N/A		44mm Optima Bond-Up	✓
DASD	N/A	DADD	N/A		44mm Optima Panelled	✓
LSASD+OP	✓	LSADD+OP	✓			
ULSASD+OP	✓	ULSADD+OP	✓			
DASD+OP	N/A	DADD+OP	N/A			
				FRAME CONSTRUCTION		
				Timber Frame (excluding MDF)	✓	
				Steel Frame	N/A	
				Aluminium Frame	N/A	
PERIMETER INTUMESCENT SEAL SPECIFICATION						
Refer to relevant figures in Appendix A, E and F for specific intumescent seal specifications						

7.11.6 Hinged Overpanels

Hinged overpanels are ***not*** permitted under the scope of this Field of Application Report

7.11.7 Removable Overpanels

Removable overpanels are ***not*** permitted under the scope of this Field of Application Report

7.11.8 Removable Transoms

Overpanels with removable transoms are ***not*** permitted under the scope of this Field of Application Report

7.12 Underpanels

Underpanels are ***not*** permitted under the scope of this Field of Application Report

7.13 Timber Door Frames

7.13.1 Timber Door Frames – Head Joints

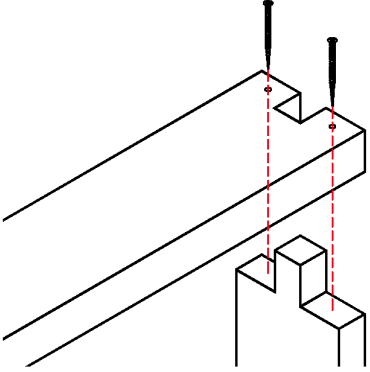
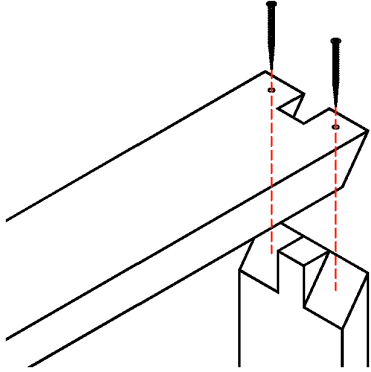
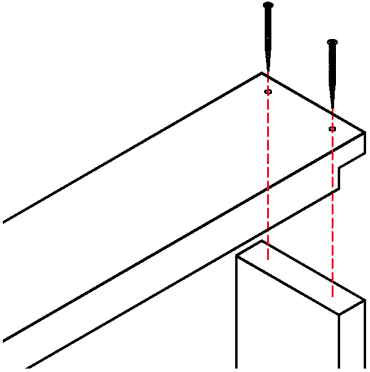
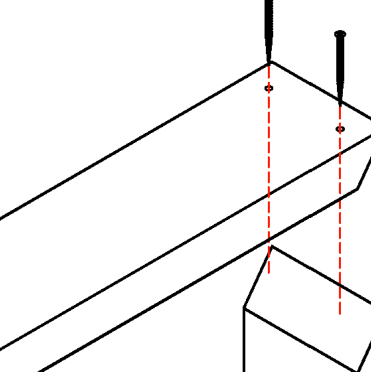
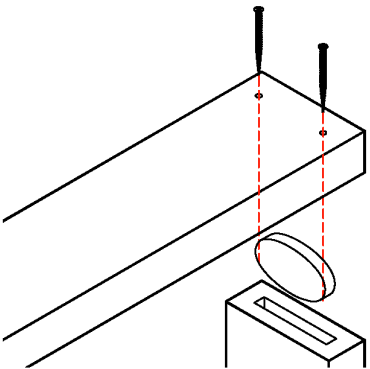
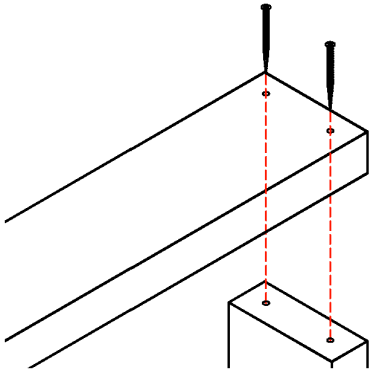
ELEMENT	SPECIFICATION/QUANTITY/DIMENSIONS
JOINT FIXINGS	<ul style="list-style-type: none"> • 2no. minimum 5mm x 80mm screws between each vertical & horizontal framing member • Screws must be of a suitable length to penetrate each jamb by a minimum of 50mm
DIAGRAMS	
FHJ30/1 - MORTICE AND TENON JOINT	FHJ30/2 – OMEC JOINT
	
FHJ30/3 – HOUSED JOINT	FHJ30/4 – MITRED JOINT
	
FHJ30/5 – BUTT JOINT WITH BISCUIT	FHJ30/6 – BUTT JOINT
	

7.13.2 Timber Door Frame Profile F30/1

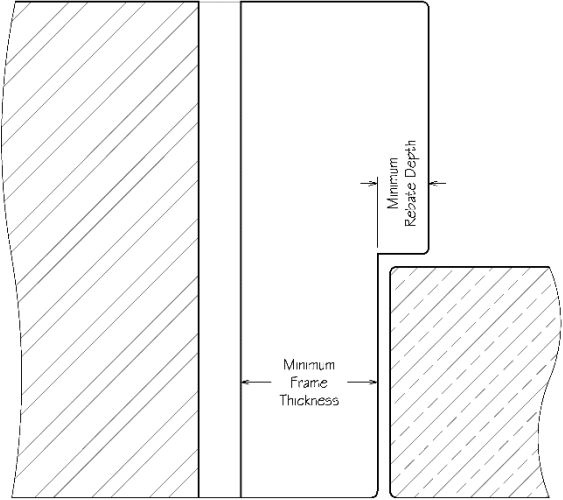
DIAGRAM	ELEMENT	SPECIFICATION/DIMENSIONS
	FRAME MATERIAL	Softwood or Hardwood
	MINIMUM DENSITY	450kg/m ³
	MINIMUM FRAME THICKNESS	30mm
	MINIMUM FRAME DEPTH	70mm
	MINIMUM REBATE DEPTH	12mm

ADDITIONAL REQUIREMENTS/NOTES

- The primary frame section (in the plane of the door) must not be reduced below 70mm wide. However, the overall frame depth may be increased without restriction or by utilising split frames or extension linings. The joint between the two frame sections must not intrude into the plane of the door thickness. Additional fixings may be required to prevent the frame from cupping
- The minimum frame thickness excludes the thickness of the integral door stop

DOOR CONFIGURATIONS				MAXIMUM LEAF SIZE	DOOR CONSTRUCTION	
LSASD	✓	LSADD	✓	Refer to relevant figure in Appendix A to F, as applicable for the proposed door configuration	44mm Optima	✓
ULSASD	✓	ULSADD	✓		44mm Optima Bond-Up	✓
DASD	N/A	DADD	N/A		44mm Optima Panelled	✓
LSASD+OP	✓	LSADD+OP	✓			
ULSASD+OP	✓	ULSADD+OP	✓			
DASD+OP	N/A	DADD+OP	N/A			
					FRAME CONSTRUCTION	
					Timber Frame	✓
					Steel Frame	N/A
					Aluminium Frame	N/A

PERIMETER INTUMESCENT SEAL SPECIFICATION

Refer to relevant figure in Appendix A to F, as applicable for the proposed door configuration

7.13.3 Timber Door Frame Profile F30/2

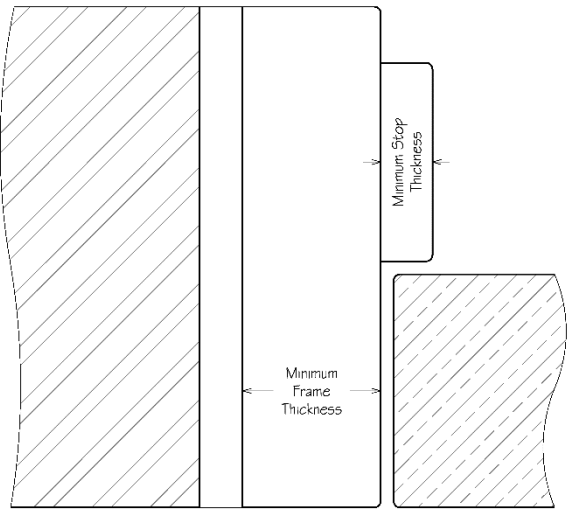
DIAGRAM	ELEMENT	SPECIFICATION/DIMENSIONS
	FRAME MATERIAL	Softwood or Hardwood MDF
	MINIMUM DENSITY	Softwood or Hardwood - 430kg/m ³ MDF - 700kg/m ³
	MINIMUM FRAME THICKNESS	Softwood or Hardwood - 30mm MDF – 30mm
	MINIMUM FRAME DEPTH	70mm
	MINIMUM STOP THICKNESS	12mm

ADDITIONAL REQUIREMENTS/NOTES

- The primary frame section (in the plane of the door) must not be reduced below 70mm wide. However, the overall frame depth may be increased without restriction or by utilising split frames or extension linings. The joint between the two frame sections must not intrude into the plane of the door thickness. Additional fixings may be required to prevent the frame from cupping
- The minimum frame thickness excludes the thickness of the integral door stop
- Overpanels are not permitted with MDF frames

DOOR CONFIGURATIONS				MAXIMUM LEAF SIZE	DOOR CONSTRUCTION	
LSASD	✓	LSADD	✓	Refer to relevant Figure in Appendix A to F, as applicable for the proposed door configuration	44mm Optima	✓
ULSASD	✓	ULSADD	✓		44mm Optima Bond-Up	✓
DASD	N/A	DADD	N/A		44mm Optima Panelled	✓
LSASD+OP	✓	LSADD+OP	✓			
ULSASD+OP	✓	ULSADD+OP	✓			
DASD+OP	N/A	DADD+OP	N/A			
*Overpanels are not permitted with MDF Frames					FRAME OPTIONS	
					Timber Frame	✓
					Steel Frame	N/A
					Aluminium Frame	N/A

PERIMETER INTUMESCENT SEAL SPECIFICATION

Refer to relevant Figure in Appendix A to F, as applicable for the proposed door configuration

7.13.4 Timber Door Frame Profile F30/3

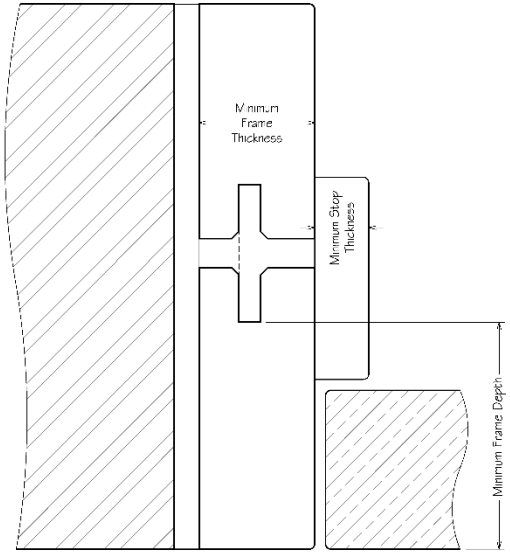
DIAGRAM	ELEMENT	SPECIFICATION/DIMENSIONS
	FRAME MATERIAL	Softwood or Hardwood MDF
	MINIMUM DENSITY	Softwood or Hardwood - 430kg/m ³ MDF - 700kg/m ³
	MINIMUM FRAME THICKNESS	Hardwood - 32mm MDF – 30mm
	MINIMUM FRAME DEPTH	70mm
	MINIMUM STOP THICKNESS	12mm

ADDITIONAL REQUIREMENTS/NOTES

- A maximum 15mm deep x 10mm wide groove may be included in the edge of each frame section to house the tongue
- The tongue between the frame sections may be manufactured from MDF or hardwood
- The primary frame section (in the plane of the door) must not be reduced below 70mm wide
- The joint between the two frame sections must not intrude into the plane of the door thickness
- Additional frame sections may be added as required to suit the proposed wall depth, provided the requirements detailed above are met
- The minimum frame thickness excludes the thickness of the planted door stop

DOOR CONFIGURATIONS				MAXIMUM LEAF SIZE	DOOR CONSTRUCTION	
LSASD	✓	LSADD	✓	Refer to relevant figure in Appendix A to F, as applicable for the proposed door configuration	44mm Optima	✓
ULSASD	✓	ULSADD	✓		44mm Optima Bond-Up	✓
DASD	N/A	DADD	N/A		44mm Optima Panelled	✓
LSASD+OP	✓	LSADD+OP	✓			
ULSASD+OP	✓	ULSADD+OP	✓			
DASD+OP	N/A	DADD+OP	N/A			
*Overpanels are not permitted with MDF Frames					FRAME CONSTRUCTION	
					Timber Frame	✓
					Steel Frame	N/A
					Aluminium Frame	N/A
PERIMETER INTUMESCENT SEAL SPECIFICATION						
Refer to relevant figure in Appendix A to F, as applicable for the proposed door configuration						

7.13.5 Timber Door Frame Profile F30/4

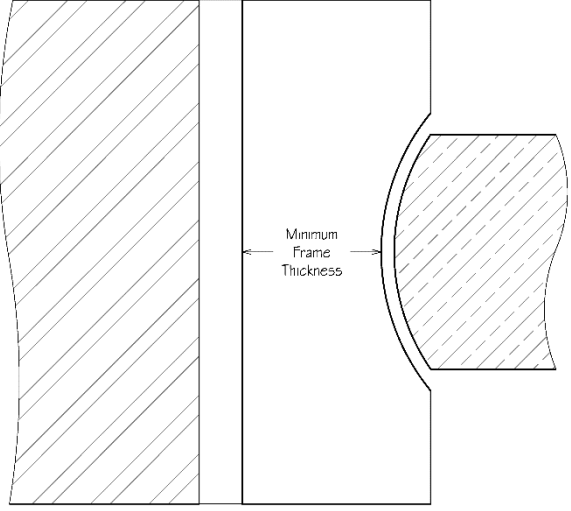
DIAGRAM	ELEMENT	SPECIFICATION/DIMENSIONS
	FRAME MATERIAL	Softwood or Hardwood
	MINIMUM DENSITY	430kg/m ³
	MINIMUM FRAME THICKNESS	35mm
	MINIMUM FRAME DEPTH	95mm
	MINIMUM STOP THICKNESS	N/A

ADDITIONAL REQUIREMENTS/NOTES

- The primary frame section (in the plane of the door) must not be reduced below 95mm wide. However, the overall frame depth may be increased without restriction or by utilising split frames or extension linings. The joint between the two frame sections must not intrude into the plane of the door thickness. Additional fixings may be required to prevent the frame from cupping
- The minimum frame thickness detailed above applies after the scallop is formed in the frame
- The radius to the door frame and pivot edge may be adjusted to suit the selected pivot/floor spring
- Door edge gaps must be maintained at a maximum of 4mm over the full length of the pivot stile/scallop radius
- The primary closing jambs for single leaf doors must be as detailed in Section F30/1 & F30/2

DOOR CONFIGURATIONS				MAXIMUM LEAF SIZE	DOOR CONSTRUCTION	
LSASD	N/A	LSADD	N/A	Refer to relevant figure in Appendix A, as applicable for the proposed door configuration	44mm Optima	✓
ULSASD	N/A	ULSADD	N/A		44mm Optima Bond-Up	N/A
DASD	✓	DADD	✓		44mm Optima Panelled	N/A
LSASD+OP	N/A	LSADD+OP	N/A			
ULSASD+OP	N/A	ULSADD+OP	N/A			
DASD+OP	N/A	DADD+OP	N/A			
					FRAME CONSTRUCTION	
					Timber Frame	✓
					Steel Frame	N/A
					Aluminium Frame	N/A

PERIMETER INTUMESCENT SEAL SPECIFICATION

Refer to relevant figure in Appendix A, as applicable for the proposed door configuration

7.13.6 Timber Door Frame Profile F30/5

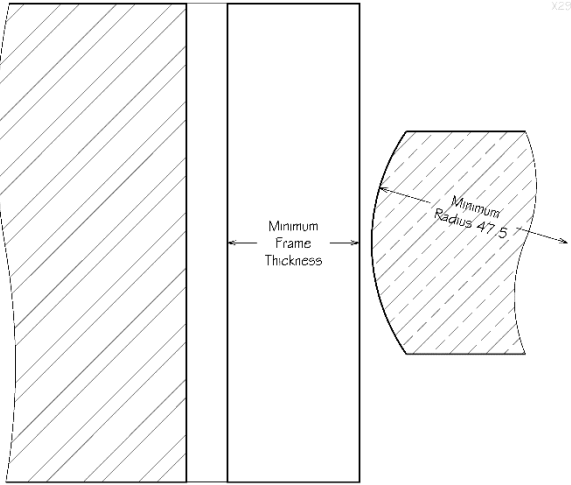
DIAGRAM	ELEMENT	SPECIFICATION/DIMENSIONS
		<p>This frame profile is <i>not</i> permitted under the scope of this Field of Application Report</p>

7.13.7 Timber Door Frame Profile F30/6

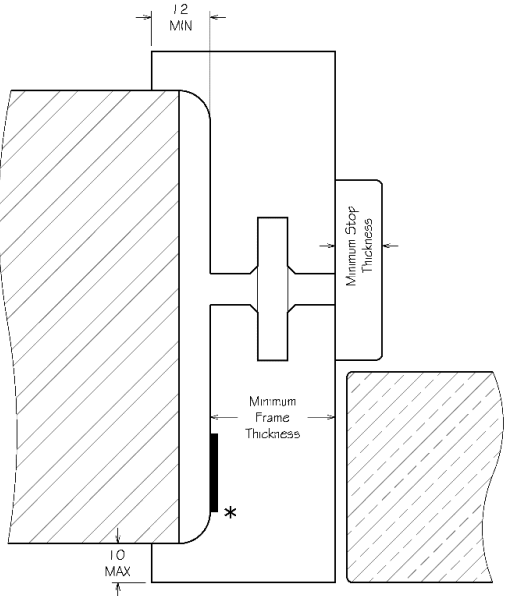
DIAGRAM	ELEMENT	SPECIFICATION/DIMENSIONS
		<p>This frame profile is <i>not</i> permitted under the scope of this Field of Application Report</p>

7.13.8 Timber Door Frame Profile F30/7

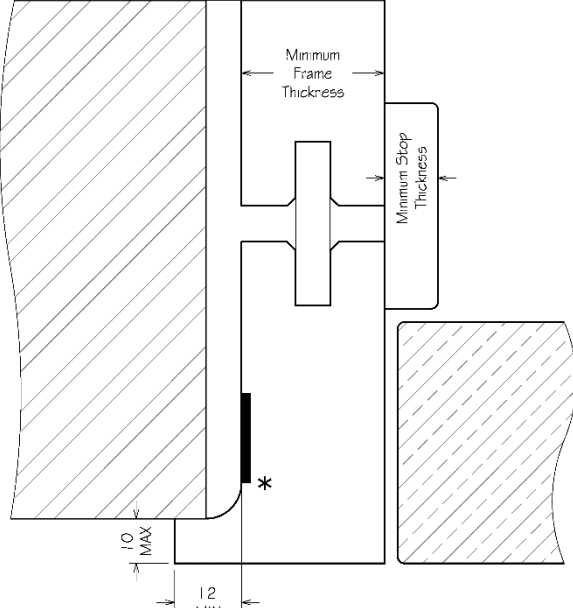
DIAGRAM	ELEMENT	SPECIFICATION/DIMENSIONS
		<p>This frame profile is <i>not</i> permitted under the scope of this Field of Application Report</p>

7.13.9 Timber Door Frame Profile F30/8

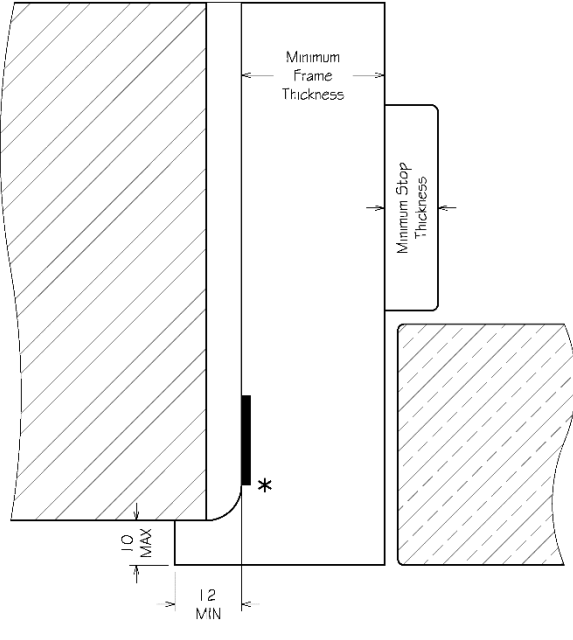
DIAGRAM	ELEMENT	SPECIFICATION/DIMENSIONS
		<p>This frame profile is <i>not</i> permitted under the scope of this Field of Application Report</p>

7.13.10 Timber Door Frame Profile F30/9

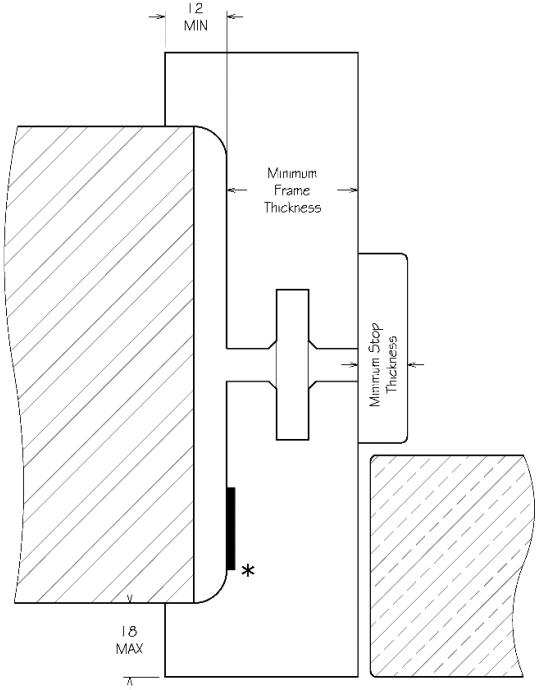
DIAGRAM	ELEMENT	SPECIFICATION/DIMENSIONS
		<p>This frame profile is <i>not</i> permitted under the scope of this Field of Application Report</p>

7.13.11 Timber Door Frame Profile F30/10

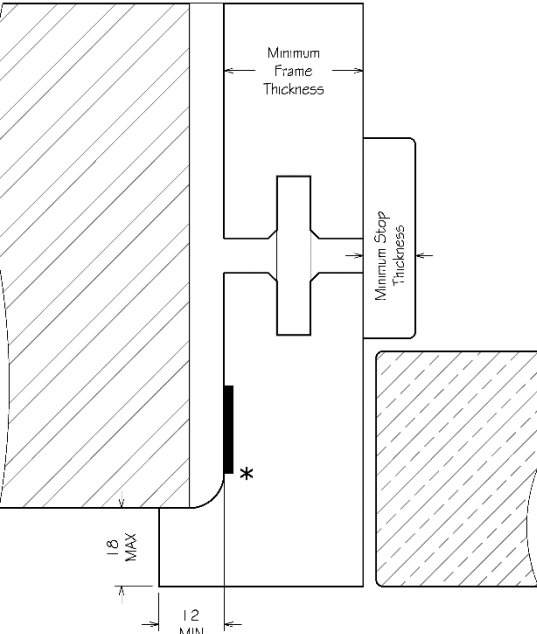
DIAGRAM	ELEMENT	SPECIFICATION/DIMENSIONS
		<p>This frame profile is <i>not</i> permitted under the scope of this Field of Application Report</p>

7.13.12 Timber Door Frame Profile F30/11

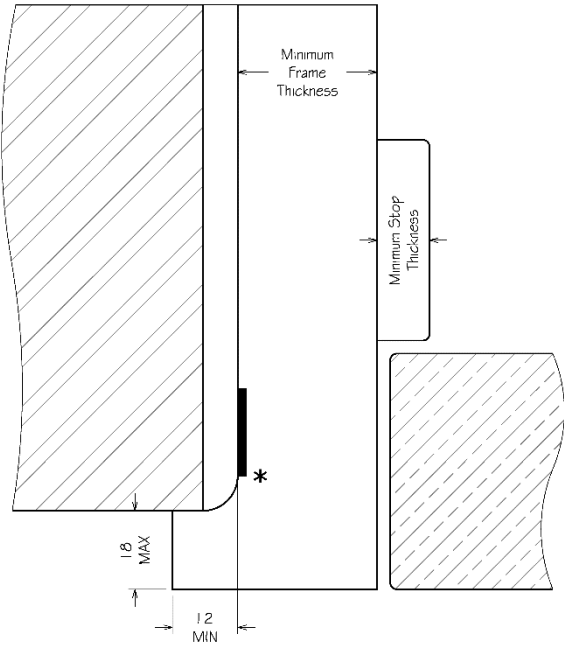
DIAGRAM	ELEMENT	SPECIFICATION/DIMENSIONS
		<p>This frame profile is <i>not</i> permitted under the scope of this Field of Application Report</p>

7.13.13 Timber Door Frames – Door Stops

ELEMENT	SPECIFICATION/QUANTITY/DIMENSIONS	
MATERIAL	Softwood or Hardwood (minimum density 430kg/m ³) or MDF (minimum density 700kg/m ³)	
STOP TYPES	Option 1 – Standard Stop	
	Dimensions	Minimum 20mm wide x 12mm thick
	Fixing	Mechanically fixed to the frame face – refer to Section 7.19.8 for full details
	Option 2 - Stop with Location Tongue/Groove	
	<i>Not</i> permitted under the scope of this Field of Application Report	
Option 3 - Stop with Groove and Biscuits		
<i>Not</i> permitted under the scope of this Field of Application Report		
ADDITIONAL REQUIREMENTS/NOTES	<ul style="list-style-type: none"> The width of the stop may be increased without limit to suit the door frame depth Door stop thickness may need to be increased when certain hardware items are installed – refer to Appendix G 	

7.13.14 Timber Door Frames – Architraves

ELEMENT	SPECIFICATION/QUANTITY/DIMENSIONS	
MATERIAL	Option 1	Softwood (minimum density 430kg/m ³)
	Option 2	Hardwood (minimum density 510kg/m ³)
	Option 3	MDF (minimum density 700kg/m ³)
ARCHITRAVE TYPES	Option 1 – Standard Architrave	
	Dimensions	Width to suit minimum overlap x minimum 15mm thick
	Profile	Architraves may be square/rectangular or profiled
	Fixing	<ul style="list-style-type: none"> • Mechanically fixed to edge of door frame & face of the supporting construction • Must overlap the frame and supporting construction by a minimum of 15mm • Refer to Section 7.19.9 for full details
	Option 2 - Architrave with Location Tongue/Groove	
	<u>Not</u> permitted under the scope of this Field of Application Report	
	Option 3 - Stop with Groove and Biscuits	
<u>Not</u> permitted under the scope of this Field of Application Report		
ADDITIONAL REQUIREMENTS/NOTES	<ul style="list-style-type: none"> • Where architraves are required in specific gap sealing configurations (see Section 7.20) they must be in accordance with the specification detailed above • Where architraves are not required in specific gap sealing configurations (see Section 7.20) and the edge of the frame is flush with the face of the wall, then loose architraves are optional. In this scenario, the width, thickness and density of the architraves can be adjusted freely 	

7.13.15 Timber Door Frames – Extension Linings

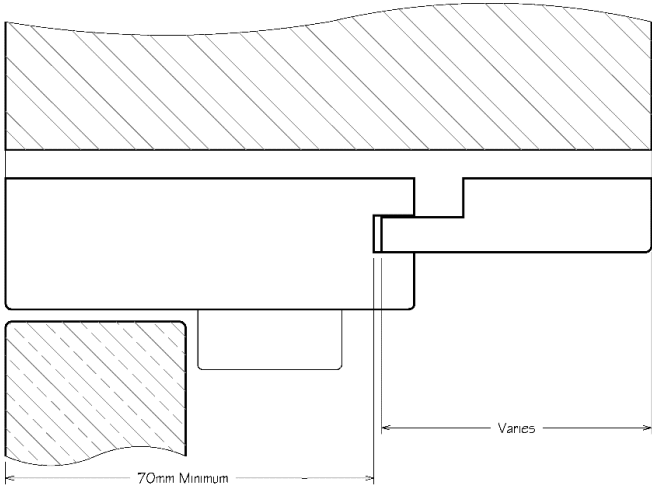
DIAGRAM				
				
ELEMENT	SPECIFICATION/QUANTITY/DIMENSIONS			
DIMENSIONS	No limitations on the width/thickness of the extension linings provided the requirements herein are met			
MATERIAL	The extension lining material must be selected from the options below, but it may differ from that used for the door frame			
	<table border="1"> <tr> <td>Option 1</td> <td>Softwood or Hardwood (minimum density 430kg/m³)</td> </tr> <tr> <td>Option 2</td> <td>MDF (minimum density 700kg/m³)</td> </tr> </table>	Option 1	Softwood or Hardwood (minimum density 430kg/m ³)	Option 2
Option 1	Softwood or Hardwood (minimum density 430kg/m ³)			
Option 2	MDF (minimum density 700kg/m ³)			
EXTENSION LINING GROOVE	<ul style="list-style-type: none"> A maximum 10x10mm groove may be included in the door frame to house the extension lining tongue The groove must not encroach into the minimum frame section size, as depicted above 			
ADDITIONAL REQUIREMENTS/NOTES				
<ul style="list-style-type: none"> Extension linings may be used in conjunction with any of the timber frame profiles approved in Section 7.13 (the diagram above is typical) Linear gap sealing systems must be applied to the primary frame section (in the plane of the door) and not behind the extension lining – refer to Section 7.20 for more details 				

DOOR CONFIGURATIONS				MAXIMUM LEAF SIZE	DOOR CONSTRUCTION	
LSASD	✓	LSADD	✓	Refer to relevant figure in Appendix A to F, as applicable for the proposed door configuration	44mm Optima	✓
ULSASD	✓	ULSADD	✓		44mm Optima Bond-Up	✓
DASD	✓	DADD	✓		44mm Optima Panelled	✓
LSASD+OP	✓	LSADD+OP	✓			
ULSASD+OP	✓	ULSADD+OP	✓			
DASD+OP	N/A	DADD+OP	N/A			
				FRAME CONSTRUCTION		
				Timber Frame	✓	
				Steel Frame	N/A	
				Aluminium Frame	N/A	

PERIMETER INTUMESCENT SEAL SPECIFICATION
Refer to relevant figure in Appendix A to F, as applicable for the proposed door configuration

7.13.16 Timber Door Frames – Decorative Facings

ELEMENT	SPECIFICATION/QUANTITY/DIMENSIONS			
DECORATIVE FACING OPTIONS	Option 1	Timber veneer	Option 4	Cellulosic foil
	Option 2	High Pressure Laminate (HPL)	Option 5	Vinyl
	Option 3	Paper		
MAXIMUM FACING THICKNESS	2mm			
FACING ADHESIVE OPTIONS	Option 1	Polyurethane	Option 3	Urea Formaldehyde
	Option 2	Resorcinol Formaldehyde	Option 4	PVA
ADDITIONAL REQUIREMENTS/NOTES	Other than the use of timber veneer, these facings are permitted to be fitted to the face of the frame only and may not return around the frame reveal.			

7.13.17 Timber Door Frames – Decorative Finishes

ELEMENT	SPECIFICATION/QUANTITY/DIMENSIONS			
PERMITTED APPLICATION AREA	All faces of the door frame			
DECORATIVE FINISH OPTIONS	Option 1	Paint	Option 4	Stain
	Option 2	Lacquer	Option 3	Varnish
MAXIMUM FINISH THICKNESS	0.5mm, or a maximum of 5 coats, whichever is greater, per leaf face			
ADDITIONAL REQUIREMENTS/NOTES	None			

DOOR CONFIGURATIONS				MAXIMUM LEAF SIZE	DOOR CONSTRUCTION	
LSASD	✓	LSADD	✓	Refer to relevant figure in Appendix A to F, as applicable for the proposed door configuration	44mm Optima	✓
ULSASD	✓	ULSADD	✓		44mm Optima Bond-Up	✓
DASD	✓	DADD	✓		44mm Optima Panelled	✓
LSASD+OP	✓	LSADD+OP	✓			
ULSASD+OP	✓	ULSADD+OP	✓			
DASD+OP	✓	DADD+OP	✓			
					FRAME CONSTRUCTION	
					Timber Frame	✓
					Steel Frame	N/A
					Aluminium Frame	N/A
PERIMETER INTUMESCENT SEAL SPECIFICATION						
Refer to relevant figure in Appendix A to F, as applicable for the proposed door configuration						

7.13.18 Timber Door Frames – PVC Encapsulated Frames

PVC encapsulated door frames are ***not*** permitted under the scope of this Field of Application Report

7.13.19 Timber Door Frames – Raised Threshold / 4-Sided Frames

Raised threshold/4-sides frames are ***not*** permitted under the scope of this Field of Application Report

7.13.20 Timber Door Frames – Shadow Gaps

Shadow gaps are ***not*** permitted under the scope of this Field of Application Report

7.14 Steel Door Frames

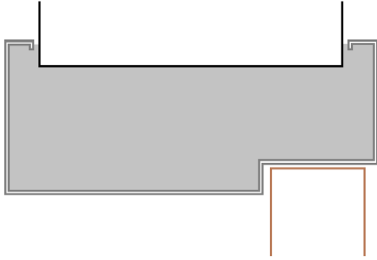
DIAGRAM	
	
ELEMENT	SPECIFICATION/QUANTITY/DIMENSIONS
FRAME PROFILE	Box profile as detailed in the diagram above – minimum dimensions of 180mm wide x 45mm thick with a 15mm deep integral stop
FRAME MATERIAL	1.5mm thick mild steel frame with integral stop
FRAME HEAD JOINT	Mitred with welded joints or bolted tabs
BACKFILLING REQUIREMENTS	<ul style="list-style-type: none"> Backfilled with mortar it shall be ensured that no voids are present
FIXING REQUIREMENTS	Full width 25mm high x 5mm thick steel straps must be welded to the rear of the steel door frames at each fixing position. See also Section 7.19.4
ADDITIONAL REQUIREMENTS/NOTES	Transom members, overpanels (transomed or flush) and underpanels are not permitted with steel frames

DOOR CONFIGURATIONS				MAXIMUM LEAF SIZE	DOOR CONSTRUCTION	
LSASD	✓	LSADD	✓	Refer to relevant figure in Appendix C, as applicable for the proposed door configuration	44mm Optima	✓
ULSASD	✓	ULSADD	✓		44mm Optima Bond-Up	N/A
DASD	N/A	DADD	N/A		4mm Optima Panelled	N/A
LSASD+OP	N/A	LSADD+OP	N/A			
ULSASD+OP	N/A	ULSADD+OP	N/A			
DASD+OP	N/A	DADD+OP	N/A			
PERIMETER INTUMESCENT SEAL SPECIFICATION						
Refer to relevant figure in Appendix C, as applicable for the proposed door configuration						

7.15 Aluminium Door Frames

DIAGRAM	
As tested in WARRES 18289	
ELEMENT	SPECIFICATION/QUANTITY/DIMENSIONS
FRAME PROFILE	Neslo Mark 4 door frame
FRAME MATERIAL	Extruded Aluminium with sapele subframe (87mm x20mm)
FRAME HEAD JOINT	15mm x 3mm diameter steel rivet, 1no per joint
FIXING REQUIREMENTS	As tested in WARRES 188289. See also Section 7.19.5
ADDITIONAL REQUIREMENTS/NOTES	Transom members, overpanels (transomed or flush) and underpanels are not permitted with aluminium frames

DOOR CONFIGURATIONS				MAXIMUM LEAF SIZE	DOOR CONSTRUCTION	
LSASD	✓	LSADD	✓	Refer to relevant figure in Appendix D, as applicable for the proposed door configuration	44mm Optima	✓
ULSASD	✓	ULSADD	✓		44mm Optima Bond-Up	N/A
DASD	N/A	DADD	N/A		44mm Optima Panelled	N/A
LSASD+OP	N/A	LSADD+OP	N/A			
ULSASD+OP	N/A	ULSADD+OP	N/A			
DASD+OP	N/A	DADD+OP	N/A			
PERIMETER INTUMESCENT SEAL SPECIFICATION						
Refer to relevant figure in Appendix D, as applicable for the proposed door configuration						

7.16 Glazed Apertures

7.16.1 General Requirements

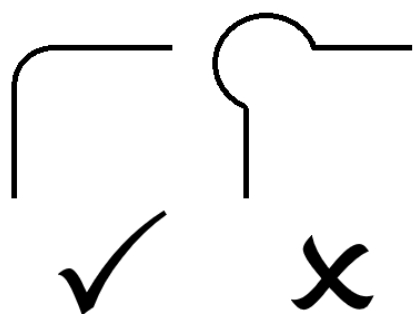
GENERAL REQUIREMENTS								
GENERAL INSTALLATION	All glass is to be installed in accordance with the manufacturer's instructions for expansion allowance, setting blocks, silicone pointing etc							
APERTURE SIZE/AREA	<table border="1"> <tr> <td rowspan="3">Maximum Total Permitted Aperture Area (Per Door Leaf)</td> <td>Optima Solid</td> <td>0.80m²</td> </tr> <tr> <td>Optima Bond-Up</td> <td>0.80m²</td> </tr> <tr> <td>Optima Panelled</td> <td>0.40m²</td> </tr> </table>	Maximum Total Permitted Aperture Area (Per Door Leaf)	Optima Solid	0.80m ²	Optima Bond-Up	0.80m ²	Optima Panelled	0.40m ²
	Maximum Total Permitted Aperture Area (Per Door Leaf)		Optima Solid	0.80m ²				
Optima Bond-Up			0.80m ²					
Optima Panelled		0.40m ²						
	<ul style="list-style-type: none"> The total permitted aperture area detailed above may comprise single or multiple apertures, subject to the maximum permitted glazed aperture dimensions for each glazing system, which are detailed in Section 7.16.2 The total combined area of all glazed apertures, air transfer grilles and/or letter plates (where fitted) must not exceed the total aperture area detailed above 							
APERTURE SHAPE	The approved aperture scope detailed herein is based on the use of square or rectangular apertures							
ALTERNATIVE APERTURE SHAPES	<ul style="list-style-type: none"> Alternative aperture shapes (not square or rectangular) may be used, provided the glass and glazing system have been successfully fire tested in accordance with BS476: Part:1987 or BS EN 1634-1 for 30 minutes when fitted within a 44mm thick Halspan Optima door leaf in the same aperture shape as proposed All details of the glazed aperture, including but not limited to - size, glazing seals, bead profile/size, bead fixings and glass type/thickness must remain as fire tested Aperture margins and total permitted aperture area must be in accordance with that detailed herein Maximum 5mm radius corners/edges are permitted at the edges of the glass. This detail must have been successfully fire tested in accordance with BS476: Part:1987 or BS EN 1634-1 for 30 minutes, for the specific glass type. This is limited to a radius being used within the corner of the aperture and does not permit the use of a radius that protrudes from the aperture margin. See figure below. <div style="text-align: center;">  </div>							
APERTURE MARGINS	Refer to Section 7.16.2							
APERTURE LINER	A hardwood liner meeting the specification below may be fitted to the perimeter of the glazed aperture. See Section 7.16.3-7.16.9 for guidance on when the use of a liner is mandatory.							
	Material	Hardwood – not Beech (Minimum density 640kg/m ³)						
	Thickness	6-8mm						
	Adhesive	Urea formaldehyde, Phenol formaldehyde or PU						

GENERAL REQUIREMENTS	
ETCHING, ENGRAVING & SANDBLASTING	Etching, engraving and sandblasting of glass faces is <i>not</i> permitted under the scope of this Field of Application Report
MANIFESTATIONS	The application of vinyl or screen-printed manifestations is <i>not</i> permitted under the scope of this Field of Application Report
SCREW CUPS	<ul style="list-style-type: none"> Surface mounted or recessed/knurled screw cups manufactured from brass or steel, may be used in conjunction with the screw fixings When using recessed/knurled screw cups, the top of the screw head must sit flush with the top face of the glazing bead
PLUGS/PELLETS	Plugs/pellets are permitted, maximum plus/pellet size must not exceed 2mm deep, there must be no gap between the top of the fixing/bottom of the plugs/pellets.

7.16.2 Glazed Aperture Margins

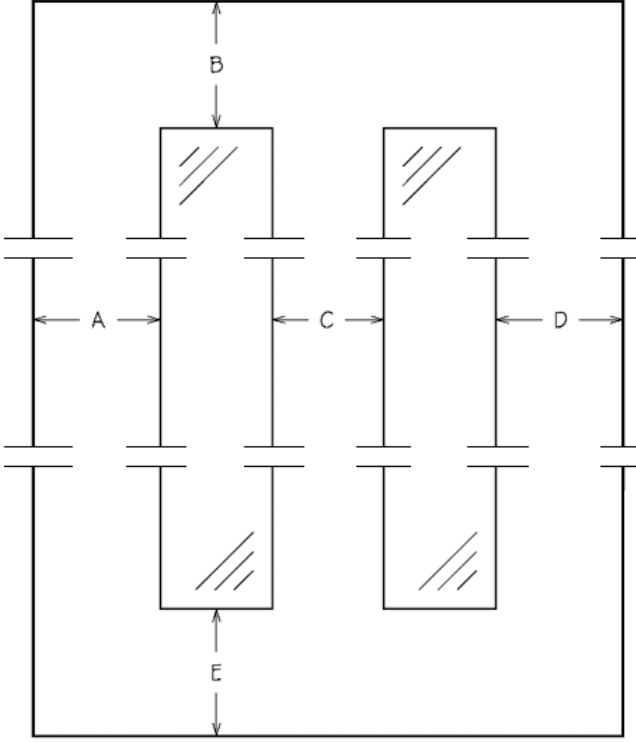
DIAGRAM	KEY		
	A	Stile	100mm
	B	Top Rail	*100mm
	C	Muntin / Intermediate Rail	**80mm
	D	Stile	100mm
	E	Bottom Rail	200mm

ADDITIONAL REQUIREMENTS/NOTES
<ul style="list-style-type: none"> There must be a minimum 50mm margin between each glazed aperture and any hardware item, feature groove, recessed panel/area and/or concealed cableway, as applicable. This minimum dimension must be measured edge-to-edge and not centre-to-centre. This may necessitate the increase of the minimum aperture margins detailed above *If a concealed overhead closer is included the head of the door leaf, the top rail (dimension B) must be a minimum of 200mm high **Maximum width/height of glazed aperture using an 80mm intermediate rail/muntin must not exceed 308mm, respectively

7.16.3 10 x 2mm Therm-A-Strip

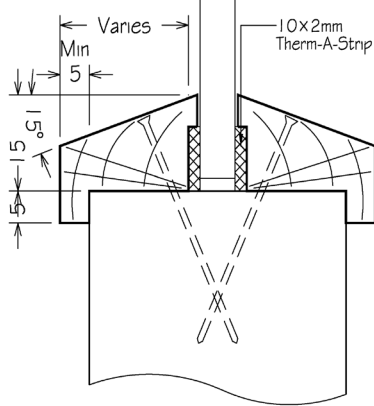
#	SPECIFICATION/QUANTITY/DIMENSIONS	DIAGRAM
1	<p>GLAZING SEAL</p> <p>10 x 2mm thick Therm-A-Strip thick bead between glass and bead</p>	
2	<p>GLAZING LINER</p> <p>None required</p>	
3	<p>GLAZING BEAD</p> <ul style="list-style-type: none"> 20mm high x 24mm deep bead including a 5x5mm bolection return 10 x 2mm recess in rear face of bead to accommodate the intumescent seal 2mm expansion allowance at all edges 15-20 degree splayed top Hardwood – not Beech (minimum density 640kg/m³) 	
4	<p>GLAZING BEAD FIXINGS</p> <ul style="list-style-type: none"> 40mm x Ø1.6mm steel pins or 40mm x Ø4mm steel wood screws 50mm from each corner and on 150mm centres thereafter Fixed at an angle of 15-20 degrees relative to glass face Shank of the pin/screw as close as possible to the perimeter of the glass 	

GLASS TYPE

THICKNESS	MANUFACTURER	TYPE	INTEGRITY	INSULATION
6mm	Pilkington	Pyroshield	30	NPD

GLAZED APERTURE ENVELOPE

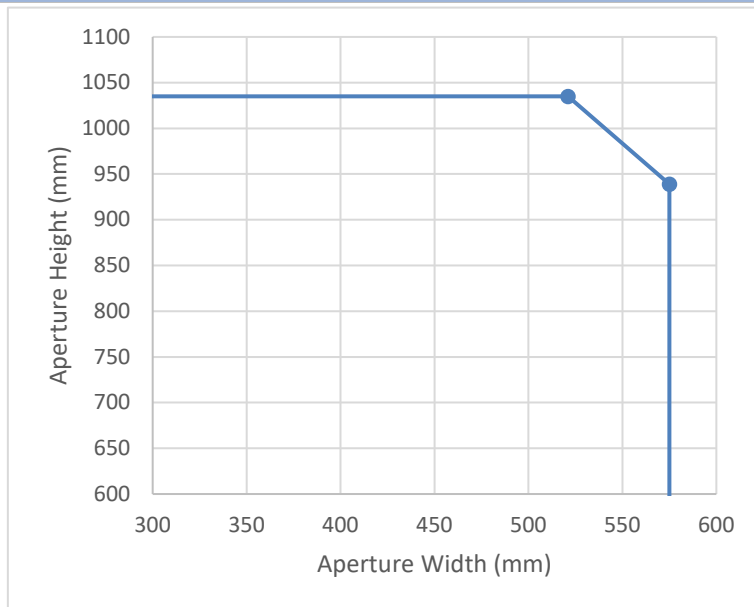

HEIGHT	WIDTH
939mm	575mm
1035mm	521mm

FIRE TEST EVIDENCE

RF01103, RF, RF00067

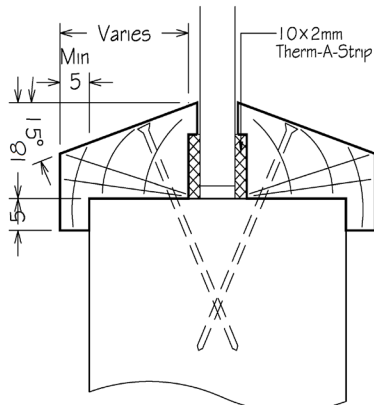
#	SPECIFICATION/QUANTITY/DIMENSIONS	DIAGRAM
1	GLAZING SEAL 10 x 2mm thick Therm-A-Strip thick bead between glass and bead	
2	GLAZING LINER None required	
3	GLAZING BEAD <ul style="list-style-type: none"> • 23mm high bead including a 5x5mm bolection return • 25mm glass edge cover • 10 x 2mm recess in rear face of bead to accommodate the intumescent seal • Hardwood – not Beech (minimum density 640kg/m³) 	
4	GLAZING BEAD FIXINGS <ul style="list-style-type: none"> • 50mm x Ø1.6mm steel pins or 50mm x Ø4mm steel wood screws • 50mm from each corner and on 150mm centres thereafter • Fixed at an angle of 15-20 degrees relative to glass face • Shank of the pin/screw as close as possible to the perimeter of the glass 	

GLASS TYPE

THICKNESS	MANUFACTURER	TYPE	INTEGRITY	INSULATION
7mm	Pyroguard	EW30	30	NPD

GLAZED APERTURE ENVELOPE

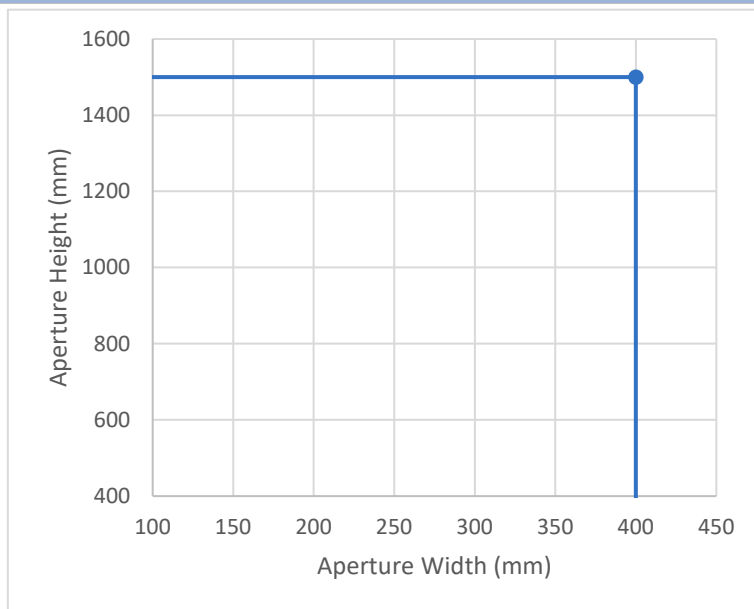

HEIGHT	WIDTH
1500mm	400mm

FIRE TEST EVIDENCE

WF412654

#	SPECIFICATION/QUANTITY/DIMENSIONS	DIAGRAM
1	GLAZING SEAL 10 x 2mm thick Therm-A-Strip thick bead between glass and bead	
2	GLAZING LINER None required	
3	GLAZING BEAD <ul style="list-style-type: none"> 12mm high x 20mm deep bead (including a 2x3mm quirk rebate) 2mm expansion allowance at all edges Hardwood – not Beech (minimum density 640kg/m³) 	
4	GLAZING BEAD FIXINGS <ul style="list-style-type: none"> 40mm x Ø1.6mm steel pins or 40mm x Ø4mm steel wood screws 50mm from each corner and on 150mm centres thereafter Fixed at an angle of 15-20 degrees relative to glass face Shank of the pin/screw as close as possible to the perimeter of the glass 	

GLASS TYPE

THICKNESS	MANUFACTURER	TYPE	INTEGRITY	INSULATION
6mm	Sureglaze	Wired	30	NPD

GLAZED APERTURE ENVELOPE





HEIGHT	WIDTH
626mm	172mm
690mm	156mm

FIRE TEST EVIDENCE

RF01073

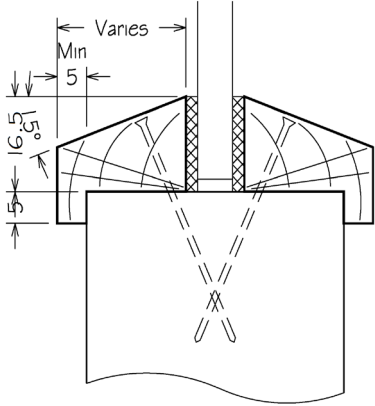
7.16.4 2mm Sealmaster Fireglaze Compound

#	SPECIFICATION/QUANTITY/DIMENSIONS	DIAGRAM		
1	<p>GLAZING SEAL</p> <p>Sealmaster Fireglaze Compound, 2mm thick bead between glass and bead</p>			
2	<p>GLAZING LINER</p> <p>None required</p>			
3	<p>GLAZING BEAD</p> <ul style="list-style-type: none"> • 21.5mm high x 19mm deep bead including a 5x5mm bolection return • 2-3mm expansion allowance at all edges • 15-20 degree splayed top • Hardwood – not Beech (minimum density 640kg/m³) 			
4	<p>GLAZING BEAD FIXINGS</p> <ul style="list-style-type: none"> • 40mm x Ø1.6mm steel pins or 40mm x Ø4mm steel wood screws • 50mm from each corner and on 150mm centres thereafter • Fixed at an angle of 15-20 degrees relative to glass face • Shank of the pin/screw as close as possible to the perimeter of the glass 			
GLASS TYPE				
THICKNESS	MANUFACTURER	TYPE	INTEGRITY	INSULATION
6mm	Pilkington	Pyroshield	30	NPD
GLAZED APERTURE ENVELOPE				
			HEIGHT	WIDTH
			1055mm	362mm
			1162mm	328mm
FIRE TEST EVIDENCE				
RF11005 – Door B				

7.16.5 10 x 2mm Interdens

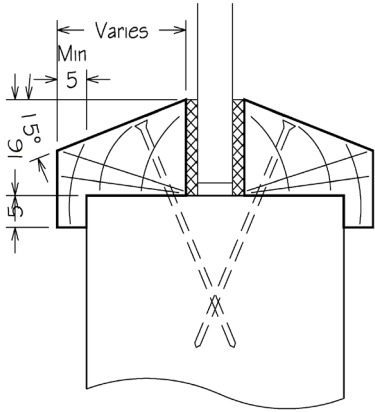
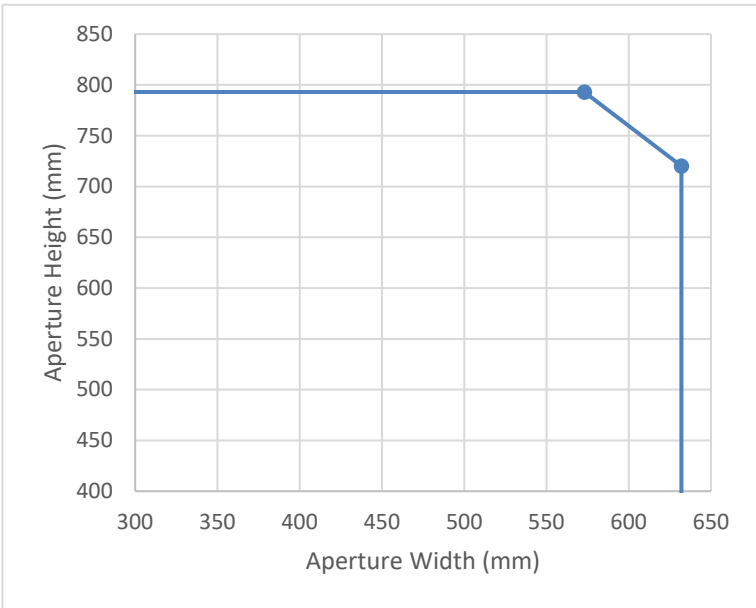
#	SPECIFICATION/QUANTITY/DIMENSIONS	DIAGRAM		
1	<p>GLAZING SEAL</p> <p>10 x 2mm thick Interdens between glass and bead</p>			
2	<p>GLAZING LINER</p> <p>None required</p>			
3	<p>GLAZING BEAD</p> <ul style="list-style-type: none"> 21mm high x 18mm wide bead including a 5x5mm bolection return 5mm expansion allowance at all edges 15-20 degree splayed top Hardwood – not Beech (minimum density 640kg/m³) 			
4	<p>GLAZING BEAD FIXINGS</p> <ul style="list-style-type: none"> 50mm x Ø1.6mm steel pins or 50mm x Ø4mm steel wood screws 50mm from each corner and on 150mm centres thereafter Fixed at an angle of 15-20 degrees relative to glass face Shank of the pin/screw as close as possible to the perimeter of the glass 			
GLASS TYPE				
THICKNESS	MANUFACTURER	TYPE	INTEGRITY	INSULATION
15mm	Pyroguard	EI30	30	NPD
GLAZED APERTURE ENVELOPE				
			HEIGHT	WIDTH
			720mm	632mm
			793mm	573mm
FIRE TEST EVIDENCE				
RF13063				

7.16.6 Sealed Tight Solutions STS105GT

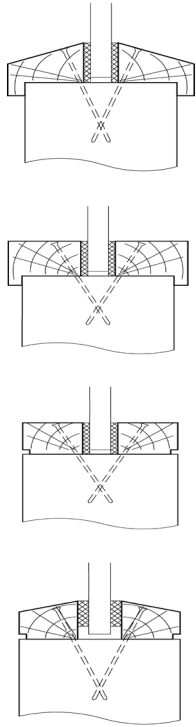
#	SPECIFICATION/QUANTITY/DIMENSIONS	DIAGRAM
1	GLAZING SEAL Sealed Tight Solution STS105GT between glass and bead	
2	GLAZING LINER None required	
3	GLAZING BEAD <ul style="list-style-type: none"> 15mm high x 17.5mm deep (including a 3mm x 3mm quirk rebate) or 20mm high x 22.5mm deep (including 5mm x 5mm bolection return) bead including a 5x5mm bolection return 2-3mm expansion allowance at all edges Square or 15-20 degree splayed top Hardwood – not Beech (minimum density 640kg/m³) 	
4	GLAZING BEAD FIXINGS <ul style="list-style-type: none"> 40mm x Ø1.6mm steel pins or 40mm x Ø4mm steel wood screws 50mm from each corner and on 150mm centres thereafter Fixed at an angle of 15-20 degrees relative to glass face Shank of the pin/screw as close as possible to the perimeter of the glass 	

GLASS TYPE

THICKNESS	MANUFACTURER	TYPE	INTEGRITY	INSULATION
7mm	AGC	Pyrobelite 7	30	NPD

GLAZED APERTURE ENVELOPE

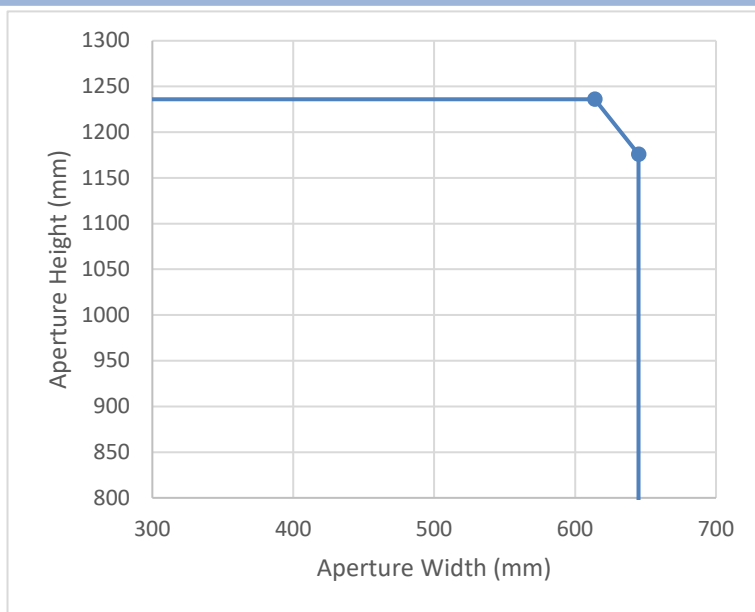

HEIGHT	WIDTH
1176mm	645mm
1236mm	614mm

FIRE TEST EVIDENCE

WF378795, BMT/FEP/F15097

7.16.7 15 x 2mm Therm-A-Strip

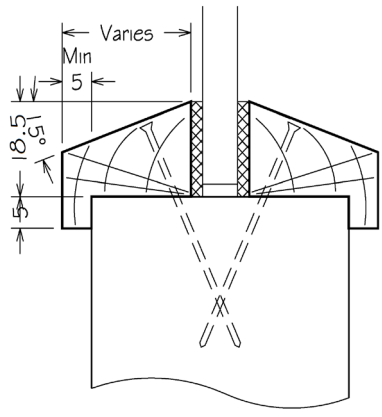
#	SPECIFICATION/QUANTITY/DIMENSIONS	DIAGRAM
1	<p>GLAZING SEAL</p> <p>15 x 2mm thick Therm-A-Strip between glass and bead</p>	
2	<p>GLAZING LINER</p> <p>None required</p>	
3	<p>GLAZING BEAD</p> <ul style="list-style-type: none"> 23.5mm high x 20mm deep bead including a 5x5mm bolection return 2.5mm expansion allowance at all edges 15-20 degree splayed top Hardwood – not Beech (minimum density 640kg/m³) 	
4	<p>GLAZING BEAD FIXINGS</p> <ul style="list-style-type: none"> 40mm x Ø4mm steel wood screws 50mm from each corner and on 150mm centres thereafter Fixed at an angle of 15-20 degrees relative to glass face Shank of the screw as close as possible to the perimeter of the glass 	

GLASS TYPE

THICKNESS	MANUFACTURER	TYPE	INTEGRITY	INSULATION
6mm	Pilkington	Pyroshield	30	NPD

GLAZED APERTURE ENVELOPE

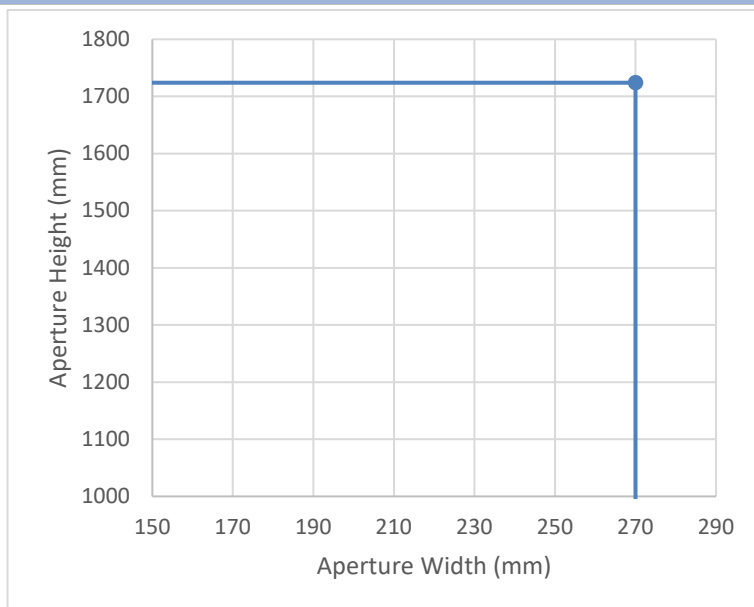

HEIGHT	WIDTH
1724mm	270mm

FIRE TEST EVIDENCE

WARRES112248 – Door A (small leaf)

7.16.8 IGC8 Glazing Channel

#	SPECIFICATION/QUANTITY/DIMENSIONS	DIAGRAM		
1	GLAZING SEAL IGC8 Glazing Channel			
2	GLAZING LINER None required			
3	GLAZING BEAD <ul style="list-style-type: none"> 23mm wide x 19mm high bead including a 5x5mm bolection return 2mm expansion allowance at all edges 15-20 degree splayed top Hardwood – not Beech (minimum density 640kg/m³) 			
4	GLAZING BEAD FIXINGS <ul style="list-style-type: none"> 50mm x Ø1.6mm steel pins or 50mm x Ø4mm steel wood screws 50mm from each corner and on 150mm centres thereafter Fixed at an angle of 15-20 degrees relative to glass face Shank of the pin/screw as close as possible to the perimeter of the glass 			
GLASS TYPE				
THICKNESS	MANUFACTURER	TYPE	INTEGRITY	INSULATION
6mm	Pilkington	Pyroshield	30	NPD
GLAZED APERTURE ENVELOPE				
			HEIGHT	WIDTH
			991mm	770mm
			1092mm	699mm
FIRE TEST EVIDENCE				
RF99036				

7.16.9 Lorient Figure 1

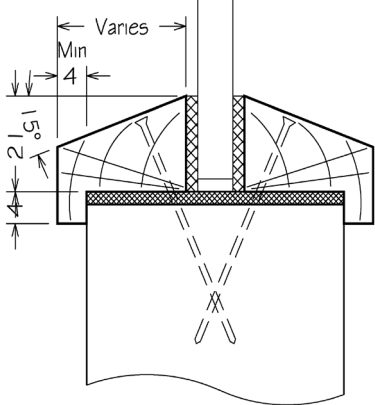
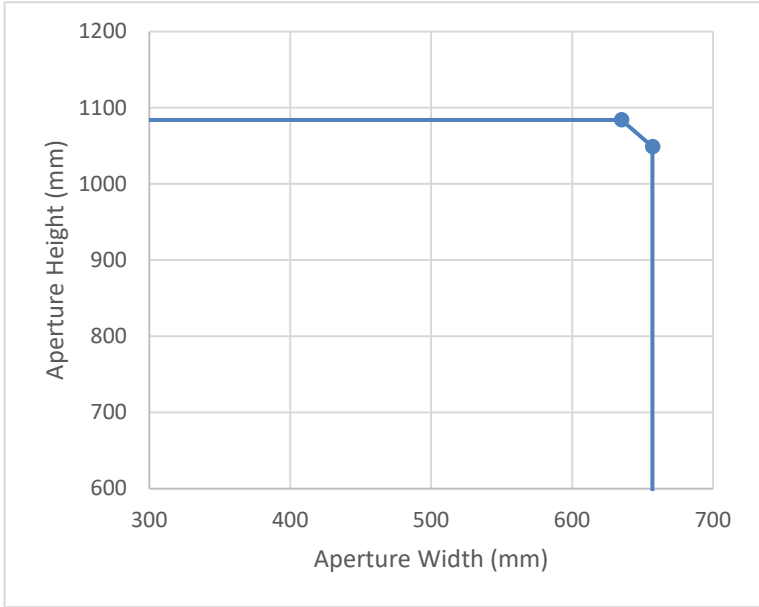
#	SPECIFICATION/QUANTITY/DIMENSIONS	DIAGRAM		
1	<p>GLAZING SEAL</p> <p>Lorient Polyproducts Ltd – Figure 1 (2mm x 17mm), self-adhered to back of bead</p>			
2	<p>GLAZING LINER</p> <p>6mm thick Hardwood liner – not Beech (minimum density 640kg/m³)</p>			
3	<p>GLAZING BEAD</p> <ul style="list-style-type: none"> • 25mm wide x 21mm high bead including a 4x4mm bolection return • 2.5mm expansion allowance at all edges • 15-20 degree splayed top • MDF (minimum density 700kg/m³) or Hardwood – not Beech (minimum density 640kg/m³) 			
4	<p>GLAZING BEAD FIXINGS</p> <ul style="list-style-type: none"> • 40mm x Ø1.6mm steel pins or 40mm x Ø4mm steel wood screws • 50mm from each corner and on 150mm centres thereafter • Fixed at an angle of 15-20 degrees relative to glass face • Shank of the pin/screw as close as possible to the perimeter of the glass 			
GLASS TYPE				
THICKNESS	MANUFACTURER	TYPE	INTEGRITY	INSULATION
6mm	Pilkington	Pyroshield	30	NPD
GLAZED APERTURE ENVELOPE				
			HEIGHT	WIDTH
			1049mm	657mm
			1084mm	635mm
FIRE TEST EVIDENCE				
WARRES 131998				

7.16.10 Privacy Glazing Systems

Privacy glazing systems are **not** permitted under the scope of this Field of Application Report

7.16.11 PVC Glazing Systems

PVC glazing systems are **not** permitted under the scope of this Field of Application Report

7.16.12 Decorative Glazing Bead Facings

The application of facings to glazing beads is **not** permitted under the scope of this Field of Application Report

7.16.13 Decorative Glazing Bead Finishes

ELEMENT	SPECIFICATION/QUANTITY/DIMENSIONS			
DESCRIPTION	Decorative glazing bead finishes may be used in conjunction with any of the glazing systems detailed in Section 7.16 subject to compliance with that detailed below			
PERMITTED APPLICATION AREA	All faces of the glazing bead			
DECORATIVE FINISH OPTIONS	Option 1	Paint	Option 4	Stain
	Option 2	Lacquer	Option 3	Varnish
MAXIMUM FINISH THICKNESS	0.5mm, or a maximum of 5 coats, whichever is greater, per leaf face			
ADDITIONAL REQUIREMENTS/NOTES	None			

7.16.14 Mock Glazing Bars/Ladder Beads

Mock glazing bars/ladder beads are **not** permitted under the scope of this Field of Application Report

7.17 Air Transfer Grilles

Air transfer grilles are **not** permitted under the scope of this Field of Application Report

7.18 Fanlights, Sidelights and Glazed Screens

Fanlights, sidelight and glazed screens are **not** permitted under the scope of this Field of Application Report

7.19 Installation and Supporting Construction

7.19.1 Supporting Construction

REQUIREMENTS/NOTES	
<ul style="list-style-type: none"> The supporting construction must have tested or assessed to provide in excess of 30 minutes fire resistance, at the required size, when incorporating door openings If fitted into timber or steel stud partitions, the method of forming the door assembly opening must be as tested by the partition and/or door assembly manufacturer When fitted into steel stud partitions, KFS recommends that the steel studs and steel head profile at the perimeter of the door assembly are reinforced with timber of a suitable section size to suit the steel profiles <p><i>Note Any reference to steel stud partitions is in the context of permanent elements, such as those designed and proven by the plasterboard manufacturers – this report does not approve use of the proposed door assemblies in proprietary ‘demountable’ partitions</i></p>	
ELEMENT	SPECIFICATION/QUANTITY/DIMENSIONS
SUPPORTING CONSTRUCTION OPTIONS - TIMBER DOOR FRAMES	Option 1 Timber stud plasterboard partition
	Option 2 Steel stud plasterboard partition
	Option 3 Masonry walls (Blockwork, brickwork & concrete)
SUPPORTING CONSTRUCTION OPTIONS – STEEL/ALUMINIUM DOOR FRAMES	Masonry walls only (Blockwork, brickwork & concrete)
ADDITIONAL REQUIREMENTS/NOTES	None

7.19.2 Oversized Structural Openings

REQUIREMENTS/NOTES	
<ul style="list-style-type: none"> Wherever possible, gaps between the rear of the door frame and structural opening should be controlled so that they meet the gap sealing requirements detailed in Section 7.20 Where the gap between the rear of the door frame and the structural opening is larger than can be filled with an approved gap sealing system (as outlined in Section 7.20), then it is permitted to line the structural opening with one of the lining material options detailed below. 	
ELEMENT	SPECIFICATION/QUANTITY/DIMENSIONS
LINING MATERIAL OPTIONS	Option 1 Plasterboard
	Option 2 Non-combustible board (e.g. Supalux)
MAXIMUM TOTAL THICKNESS OF LINING MATERIAL	20mm
FIXINGS/INSTALLATION	<ul style="list-style-type: none"> Lining materials must be bedded on a proven intumescent mastic/sealant and fixed securely to the perimeter of the structural opening, or the rear of the door frame, using steel screws on maximum 400mm centres Screws must penetrate the lining material and engage into the perimeter of the structural opening or rear of the door frame.
ADDITIONAL REQUIREMENTS/NOTES	<ul style="list-style-type: none"> Lining materials must finish flush with the face of the structural opening No gaps should be present between the lining material and the structural opening. Appropriate fire stopping should be included between the lining and door frame.

7.19.3 Timber Door Frame Fixing Requirements

ELEMENT	SPECIFICATION/QUANTITY/DIMENSIONS
FIXING TYPE	The selected fixing must be suitable for use in the type of construction surrounding the door opening (refer to fixing manufacturer/supplier for guidance)
FIXING DIAMETER	Minimum 5mm
FIXING LENGTH	<ul style="list-style-type: none"> When fixing to masonry walls, fixings must be of a sufficient length to penetrate the wall by at least 50mm When fixing to timber/steel stud partitions, fixings must be of a sufficient length to fully penetrate the timber stud or timber reinforcement within the metal studs
FIXING MATERIAL	Steel
FIXING POSITIONS	<ul style="list-style-type: none"> There must be a minimum of 1no. line of fixings. All fixings must be inset from the edge of the door frame by a minimum of 20mm
FIXING FREQUENCY	<ul style="list-style-type: none"> Fixings must be located at 150-200mm from the top and bottom of the jambs and on maximum 600mm centres thereafter A minimum of 1no. fixing must be fitted centrally across the width of the frame head in double doors
CONCEALING FIXINGS	<ul style="list-style-type: none"> Fixings may be located behind the intumescent strips or door stops Alternatively, fixing holes may be countersunk to a maximum depth of 10-15mm and then plugged/pelleted Plugs/pellets must be of the same material as the door frame and glued in place using PVA, or PU adhesive
TWO-PART FRAMES	<p>In frame profiles which comprise two or more sections, the primary frame section in the plane of the door must be fixed in accordance with the above details.</p> <p>The secondary frame section/extension linings must be fixed with a minimum 1no. line of screws at the same horizontal positions as the primary frame section</p>
EXTENSION LININGS	<p>In frame configurations which require extension linings, the primary frame section in the plane of the door must be fixed in accordance with the above details</p>

7.19.4 Steel Door Frame Fixing Requirements

ELEMENT	SPECIFICAITON/QUANTITY/DIMENSIONS
FIXING TYPE	The selected fixing must be suitable for use in the masonry wall surrounding the door opening (refer to fixing manufacturer/supplier for guidance)
FIXING DIAMETER	Minimum 5mm
FIXING LENGTH	When fixing to masonry walls, fixings must be of a sufficient length to penetrate the wall by at least 50mm
FIXING MATERIAL	Steel
FIXING STRAPS	Full width 25mm high x 5mm thick steel straps must be welded to the rear of the steel door frames at each fixing position
FIXING POSITIONS	Fixings must be fitted through access holes in the door stop, passing through the steel straps described above, before engaging into the masonry supporting construction
FIXING FREQUENCY	<ul style="list-style-type: none"> • Fixings must be located at 150-200mm from the top and bottom of the jambs and on maximum 600mm centres thereafter • A minimum of 1no. fixing must be fitted centrally across the width of the frame head in double doors
CONCEALING FIXINGS	Fixings are concealed behind flush metal discs

7.19.5 Aluminium Door Frame Fixing Requirements

ELEMENT	SPECIFICAION/QUANTITY/DIMENSIONS
FIXING TYPE	The selected fixing must be suitable for use in the masonry wall surrounding the door opening (refer to fixing manufacturer/supplier for guidance)
FIXING DIAMETER	Minimum 5mm
FIXING LENGTH	When fixing to masonry walls, fixings must be of a sufficient length to penetrate the wall by at least 50mm
FIXING MATERIAL	Steel
FIXING STRAPS	Full width 25mm high x 5mm thick steel straps must be welded to the rear of the steel door frames at each fixing position
FIXING POSITIONS	Fixings must be fitted through access holes in the door stop, passing through the steel straps described above, before engaging into the masonry supporting construction
FIXING FREQUENCY	<ul style="list-style-type: none"> Fixings must be located at 150-200mm from the top and bottom of the jambs and on maximum 600mm centres thereafter A minimum of 1no. fixing must be fitted centrally across the width of the frame head in double doors
CONCEALING FIXINGS	Fixings are concealed behind flush metal discs

7.19.6 Door Frame Packers

ELEMENT	SPECIFICATION/QUANTITY/DIMENSIONS
PACKER OPTIONS	Option 1 Plastic shims/packers (Such as Broadfix)
	Option 2 Timber (MDF, softwood, hardwood)
	Option 3 Non-combustible board (Such as Supalux)
FIXINGS/INSTALLATION	<ul style="list-style-type: none"> Door frame packers must be used at all fixing positions, but their use must be minimised beyond this, so as to avoid excessive interruption of the backfilling materials and gap sealant which are installed within the linear gap at the rear of the frame Typically, frame packers must be cut short of the gap sealant/wall face, unless the proposed gap sealing configuration/system has been successfully tested with frame packers which penetrate the gap sealant. Refer to Section 7.20 for further details
ADDITIONAL REQUIREMENTS/NOTES	The use of metal frame packers is <i>not</i> permitted under the scope of this Field of Application Report

7.19.7 Projecting Door Frames/Door Leaves

ELEMENT	SPECIFICATION/QUANTITY/DIMENSIONS
DESCRIPTION	It is not permitted for the door frame or door leaf to project beyond the face of the fire rated supporting construction, so as to align with decorative cladding or plasterboard on dabs. Door frames and door leaves must be installed such that they are located entirely within the plane of the fire rated supporting construction.
ADDITIONAL REQUIREMENTS/NOTES	Projecting door frames may be considered on a case by case basis by KFS

7.19.8 Door Stops

ELEMENT	SPECIFICATION/QUANTITY/DIMENSIONS
POSITION	Fixed to the face of the door frame, set maximum 3mm from the closing leaf face
FIXING	Standard stops Mechanically fixed to the door frame with steel pins (minimum 38mm x 18swg) or screws on centres no greater than 400mm
	Stops with location tongue/groove <i>Not</i> permitted under the scope of this Field of Application report
	Stops with groove and biscuits <i>Not</i> permitted under the scope of this Field of Application report
ADDITIONAL REQUIREMENTS/NOTES	None

7.19.9 Architraves

Where a gap sealing system requires architraves, they shall be installed in accordance with the following specification. When the gap sealing system has been successfully tested without architraves the following specifications do not apply, however, no frame material shall be removed for the installation of an optional/decorative architrave.

ELEMENT	SPECIFICATION/QUANTITY/DIMENSIONS
POSITION	Architraves must overlap the edge of the frame and the face of the wall by a minimum of 15mm
FIXING	Standard Architraves Mechanically fixed to the door frame with steel pins or screws on centres no greater than 400mm
	Architraves with location tongue/groove <i>Not</i> permitted under the scope of this Field of Application report
	Architraves with groove and biscuits <i>Not</i> permitted under the scope of this Field of Application report
ADDITIONAL REQUIREMENTS/NOTES	None

7.19.10 Overpanels

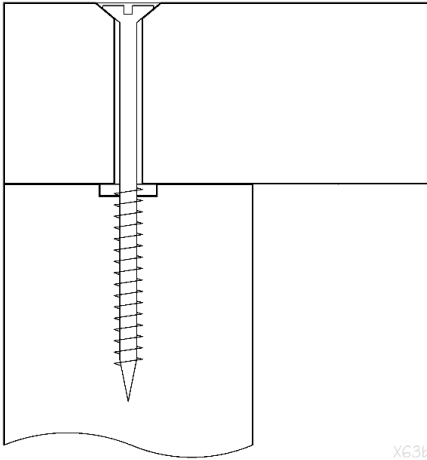
DIAGRAM		
		
ELEMENT	SPECIFICATION/QUANTITY/DIMENSIONS	
POSITION	The overpanel must be installed in the same plane as the door leaf below	
FIXINGS	Screw Size	Screws must be of suitable length to provide a minimum of 40mm penetration into each overpanel edge
	Fixing Quantity	Minimum 2no. screws per overpanel edge
	Fixing Position	Maximum 100mm from each corner and on maximum 400mm centres thereafter
ADDITIONAL REQUIREMENTS/NOTES	Intumescent protection is required around the panel perimeter. Refer to the correct Appendix Section for clarification	

7.19.11 Door Edge Gaps

ELEMENT	SPECIFICATION/QUANTITY/DIMENSIONS
GAP BETWEEN LEAF & FRAME JAMBS/HEAD	1.5mm to 4mm
GAP AT THE MEETING EDGE OF DOUBLE DOORS	1.5mm to 4mm
GAP BETWEEN OVERPANEL EDGE/S & LEAF HEAD/FRAME/TRANSOM	1.5mm to 4mm
GAP BETWEEN BOTTOM EDGE OF DOOR LEAF AND FINISHED FLOOR (FIRE ONLY)	Maximum 6mm

7.19.12 Door Leaf Alignment

REQUIREMENTS/NOTES
<ul style="list-style-type: none"> The door assembly design shall be such that when closed single acting leaves are fully flush within the frame and double acting doors must be centred on the frame depth (+/-1mm) The face of leaves in double door assemblies shall be flush with each other at meeting stiles (+/-1mm) when closed

7.20 Gap Sealing to Door Frames

7.20.1 General

GENERAL REQUIREMENTS/NOTES

- The gap sealing information detailed herein, relates to the linear gap between the door frame and surrounding construction, as depicted in the drawing below, and must not be used to support the sealing of other, unspecified gaps
- Any gap sealing systems used in conjunction with door assemblies manufactured under the scope of this report, must meet all of the requirements detailed in Section 7.20.2
- Guidance on the correct installation method for the individual components of the gap sealing system can be found in Section 7.20.3

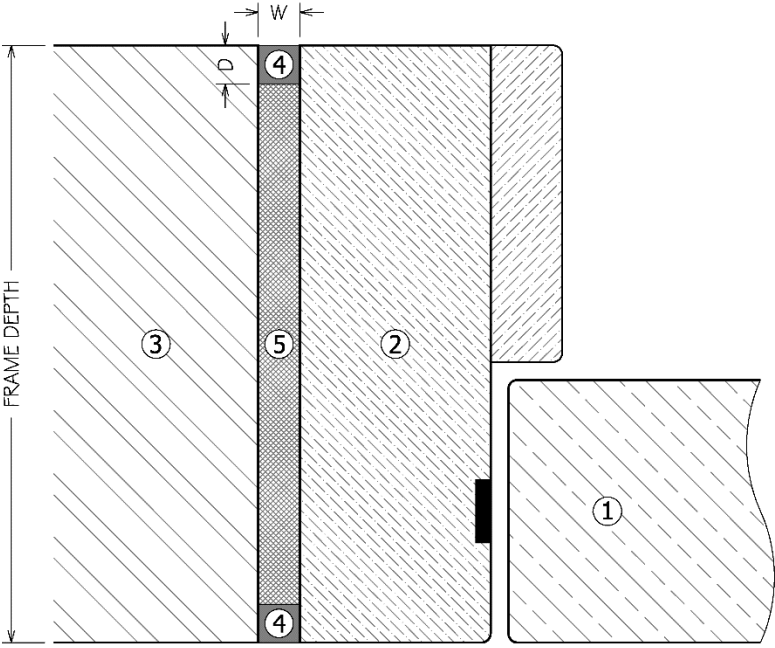
DIAGRAM	KEY	
	1	Door leaf
	2	Door frame
	3	Supporting construction (Masonry, steel stud/timber stud partition)
	4	Gap sealant
	5	Backing material
	D	Depth of gap sealant
	W	Width of gap/gap sealant

7.20.2 Requirements for Gap Sealing Systems

GENERAL REQUIREMENTS				
<ul style="list-style-type: none"> Gap sealing products used in conjunction with Halspan Optima FD30 timber door assemblies, must have been successfully fire tested for 30 minutes fire resistance in accordance with BS476: Part 22: 1987 or BS EN 1634-1:2014 meeting all of the requirements detailed below Individual components of the proposed gap sealing system must be installed in accordance with Section 7.20.3 				
1	DOOR ASSEMBLY CONFIGURATION			
<ul style="list-style-type: none"> Must have been successfully fire tested when sealing the linear gap between a door frame and the supporting construction (see restrictions on frame materials below), with the door assembly orientated so that the door leaf is opening towards the fire test furnace Gap sealing products which have been fire tested sealing linear gaps within blockwork walls are not permitted 				
2	DOOR FRAME MATERIAL			
	Tested Frame Material	Permitted Frame Material		
	Timber	Timber (Refer to Section 7.13 for approved timber door frame scope)		
	Steel	Steel (Refer to Section 7.14 for approved steel door frame scope)		
	Aluminium	Aluminium (Refer to Section 7.15 for approved steel door frame scope)		
3	GAP WIDTH			
Must have been successfully fire tested when sealing a linear gap width, equal to, or greater than, that proposed				
4	GAP SEALANT DEPTH			
Must be applied to a minimum depth of 10mm (or increased to match the depth which was fire tested with the proposed gap sealant)				
5	BACKING MATERIAL (FITTED WITHIN LINEAR GAP)			
	Tested Backing Material	Permitted Backing Material Options		
	No backing material included	None	CC Polyethylene backing rod	Expanding FR PU foam* Mineral rock fibre
	Closed cell polyethylene backing rod		CC Polyethylene backing rod	Expanding FR PU foam* Mineral rock fibre
	Expanded FR PU foam			Expanding FR PU foam* Mineral rock fibre
	Mineral rock fibre			Mineral rock fibre
* Must have been successfully fire tested when sealing a linear gap between the rear of a timber frame and a steel/timber stud partition				
6	ARCHITRAVES			
	Tested Architrave Configuration	Permitted Architrave Configuration		
	No architraves fitted	Architraves are optional		
	Architraves fitted	Architraves must be fitted		
7	DOOR FRAME PACKERS			
	Tested Packer Configuration	Permitted Frame Packer Configuration		
	Concealed (Cut short of gap sealant)	Concealed (Cut short of gap sealant)		

Tested Packer Configuration	Permitted Frame Packer Configuration	
Exposed (Penetrating gap sealant)	Concealed (Cut short of gap sealant)	Exposed (Penetrating gap sealant)

7.20.3 Installation of Gap Sealing Components

7.20.3.1 General Requirements

GENERAL REQUIREMENTS

- Wherever possible, gaps between the rear of the door frame and structural opening should be controlled so that the gap width is consistent over the entire perimeter of the door frame, and is of a size which enables the installation of a suitable gap sealing system in accordance with Section 7.20.2
- If the linear gap width varies across the perimeter of the same door frame, then it is permitted to transition from one gap sealing system to another, provided each gap sealing system used is in accordance with Section 7.20.2, and is suitable for the gap width present at its installation location

7.20.3.2 Gap Sealant

GAP SEALANT

- Gap sealant must be applied in a continuous bead over the entire length of the linear gap at the rear of the door frame there is intimate contact between the gap sealant and the adjacent surfaces
- The bead of gap sealant must finish flush with the door frame/adjacent wall
- The gap sealant must be applied to a minimum depth in accordance with Sections 7.20.2, but in linear gap widths up to 5mm, the gap may be too narrow, to apply, or measure, this minimum requirement. In this scenario, a continuous bead of gap sealant must be applied over the entire length of the linear gap to the maximum achievable depth, prior to the installation of architraves which meet the requirements of Section 7.19.9

7.20.3.3 Mineral Rock Fibre

MINERAL ROCK FIBRE

- The base density of the mineral rock fibre is not critical, provided the requirements detailed in the points below are met
- It must be ensured that mineral rock fibre is utilised. Insulation materials manufactured from, or comprising glass fibres, are not permitted
- Mineral rock fibre must be tightly packed for the full depth of the frame, over the entire length of the linear gap, with allowance made for the correct depth of gap sealant
- Interruption by the frame packers at each fixing location is permitted, but it must be ensured that the mineral rock fibre is fitted tightly packed against both sides of each packer
- There must be no large voids present within the mineral rock fibre

7.20.3.4 Closed Cell Polyethylene Backing Rods

CLOSED CELL POLYETHYLENE BACKING RODS

- Closed cell polyethylene backing rods must be installed in continuous lengths, which must only be interrupted by the frame packers at each of the frame fixing positions
- Rods must be fitted within the linear gap using a tight friction fit. To enable this, rods must always be of a larger diameter than the linear gap width into which they are being installed
- Rods must be set back from the frame/wall face to a degree which allows the correct depth of gap sealant to be applied

7.20.3.5 Expanding FR PU Foam

EXPANDING FR PU FOAM

- Expanding FR PU foam must fill the full depth of the frame, over the entire length of the linear gap, with allowance made for the correct depth of gap sealant
- There must be no large voids present within the expanding FR PU foam

7.21 Perimeter Door Seals

7.21.1 Intumescent Seals

ELEMENT	SPECIFICATION/QUANTITY/DIMENSIONS	
INTUMESCENT SEAL TYPE/S	Option 1	Graphite
	Option 2	Palusol
	Option 3	Lorient 617
MANUFACTURERS/SUPPLIERS	It is recommended that the intumescent seals are manufactured or supplied by members of the Intumescent Fire Seals Association (IFSA) or that the product is included in a Third-Party Certification scheme, such as that provided by KFS Certification, to ensure product quality and consistency.	
INTUMESCENT SEAL SIZE/POSITION	Refer to relevant figures in Appendix A to F, as applicable	
ADDITIONAL REQUIREMENTS/NOTES	<ul style="list-style-type: none"> • All perimeter intumescent seals in a door assembly must be of the same type/model/manufacture • Where possible, intumescent seals must be fitted in 2100mm lengths. Intumescent seals may be fitted in multiple lengths, provided the smallest sections are no shorter than 150mm and all lengths of intumescent seal must tightly abut one another. 	

7.21.2 Ambient Temperature Smoke Seals

Smoke seals, or combined intumescent/smoke seals (using the specification approved in Appendix A to F), that have been tested in accordance with BS EN 1634-3: 2004 (ambient temperature) or BS476: Part 31: Section 31.1: 1983 and shown not to leak by more than 3m³/m/hr at 25Pa may be used in conjunction with the proposed door assemblies to provide smoke control.

The orientation of the seals, door edge gaps, degree of hardware interruption, and leaf configuration, will need to be as tested in accordance with BS EN 1634-3: 2004 (ambient temperature) or BS476: Part 31: Section 31.1: 1983 to achieve the desired level of smoke control, unless these conflict with the intumescent seal widths and positions as described in Appendix A to F, in which case, the latter shall take precedence.

Test evidence to BS476: Part 22: 1987 shall be available to demonstrate that the smoke seals will not adversely affect the overall fire resistance of timber door assemblies, when fitted in the proposed arrangements.

This report does not provide comment or approval on the suitability of seals to achieve smoke sealing performance and it is the responsibility of others to ensure that appropriate test data is available where this specification is required.

7.21.3 Acoustic Seals

Acoustic seals or combined intumescent/acoustic seals which have been successfully fire tested in accordance with BS476: Part 22: 1987 or BS EN 1634-1:2014 may be used in conjunction with the proposed door assemblies.

Leaf thickness, leaf/frame construction and perimeter intumescent seal specification must remain as tested with the proposed acoustic seal or be in accordance with that detailed herein, whichever is greater.

Acoustic seals must be located as fire tested, or in a less onerous position unless these conflict with the intumescent seal widths and positions as described in Appendix A to F, in which case, the latter shall take precedence.

8. Conclusion

It is the evaluation of KFS that if the proposed door assemblies utilising Optima FD30 door leaves installed in timber door frames were manufactured and installed within the limitations of this Field of Application Report and tested for fire resistance, they would satisfy the integrity criteria of BS476: Part 22: 1987 for 30 minutes.

Partially insulating door assemblies are determined using the criteria given in Section 7 of BS476: Part 22: 1987. These assemblies are evaluated as partially insulating door assemblies on the basis that the 'solid' part of the leaf satisfies the temperature criteria given in Section 10.4 of BS 476: Part 20: 1987 and any non-insulating features, such as glazing, are less than 20% of the surface area of the leaf.

The assemblies outlined, herein, are permitted to have glazed areas, and so could, therefore, be evaluated to this standard if the maximum total aperture area is less than 20% of the leaf size.

The leaves may include small apertures, up to a maximum of 20% of the leaf size and can be evaluated to Section 7 in BS 476: Part 22: 1987 as partially insulating door assemblies for 30 minutes fire resistance.

The doors can also be assessed to Section 6 of BS476: Part 22: 1987 for a 30 minute performance rating for both integrity and insulation, without apertures in the or with apertures incorporating fully insulating glass.

9. Limitations

This report addresses itself solely to the ability of the proposed assemblies described to satisfy the criteria of the fire resistance test and does not imply any suitability for use with respect to other unspecified criteria.

It is the responsibility of others to establish whether the proposed product meets any other relevant requirements, including any other requirements for fire performance and life safety, as defined in documents such as the Building Regulations, and the Fire Strategy/Risk Assessment for the project.

This document only considers the door assemblies described, herein, and assumes that the surrounding construction will provide no less restraint than the tested assembly and that it will remain in place and be substantially intact for the full fire resistance period.

This assessment is issued on the basis of test data and information to hand at the time of issue. If contradictory evidence becomes available to Kiwa Fire Safety Compliance the assessment will be unconditionally withdrawn and the applicant will be notified in writing. Similarly, the assessment evaluation is invalidated if the assessed construction is subsequently tested since actual test data is deemed to take precedence.

As per the guidance outlined in the [Passive Fire Protection Forum \(PFPF\): 'Guide to undertaking technical assessments of fire performance of construction products based on fire test evidence, 2021, Industry Standard Procedure'](#), appropriate action has been taken to mitigate the risk of a conflict of interest arising during the preparation of this report. All individuals involved in the production, or subsequent review, of this assessment have declared any perceived conflicts of interest, with regards to the sponsor or subject(s) of this report, prior to working on this project.

The assessor and reviewer have been deemed suitable for involvement in the production of this assessment in accordance with the guidance outlined in the [Passive Fire Protection Forum \(PFPF\): 'Guide to undertaking technical assessments of fire performance of construction products based on fire test evidence, 2021, Industry Standard Procedure'](#).

Where the constructional information in this report is taken from details provided to Kiwa Fire Safety Compliance and/or from fire resistance test reports referenced herein, it is, therefore, limited to the information given in those documents. It is necessarily dependent upon the accuracy and completeness of that information. Where constructional or manufacturing details are not specified, or discussed, herein, it should not, therefore, be taken to infer approval of variation in such details from those tested or otherwise approved.

The analysis and conclusions within this report are based upon the likely fire resisting performance of a complete door assembly that is manufactured and installed in accordance with this document, and offered for fire resistance testing in 'perfect' condition. In practice, management procedures must be in place in any building where the door assemblies are installed, to ensure that no parts of the assembly are damaged or faulty. Further, the doors must open and close without the use of undue force. The edge gaps/alignment of door leaves must be in accordance with the tolerances defined, herein, when the doors are closed. Any such shortfalls in respect to the condition of the assemblies will invalidate the approval by KFS, and may seriously affect the ability of the assemblies to provide the required level of fire resistance performance. Determination of what constitutes wear or damage, and any corrective actions in order to return assemblies to the required condition, should only be carried out following consultation with the manufacturer and KFS.

This report is not intended to be a complete specification for the proposed assemblies and it is the responsibility of others to ensure that the assemblies are suitable for the intended purpose; whilst incorporating the requirements of this report. Further, the assemblies must be manufactured/installed by experienced/trained personnel using appropriate and established working practices/techniques.

This report applies to fire door assemblies that are evaluated to BS476: Part 22: 1987; which is an applicable test method currently referenced within guidance to Building Regulations in the United Kingdom, and in building codes in some other countries. However, KFS have a duty of care to advise that introduction of CE Marking may become compulsory for fire resisting doorsets marketed in the EU, during the validity period of this report; in which case, users should contact KFS for further details/advice.

Where the assessed constructions have not been subject to an on-site audit by Kiwa Fire Safety Compliance, it is the responsibility of anyone using this report to confirm that all aspects of the assemblies fully comply with the descriptions and limitations, herein.

Any materials specified in this report have been selected and judged primarily on their fire performance. KFS do not claim expertise in areas other than fire safety. Whilst observing all possible care in the specification of solutions, we would draw the reader's attention to the fact that during the construction and procurement process, the materials used should be subjected to more general examination regarding the wider Health and Safety, and CoSHH Regulations. Designers, manufacturers and installers are reminded of their responsibilities under the CDM Regulations; but particularly with regard to installation and maintenance of heavy or inaccessible items.

This assessment considers the fire resistance performance of the door assemblies when tested with the leaves in the closed position, within the frame reveal; either retained by the latch, or self-closing device, or locked shut, as applicable. The door assemblies will only provide the assessed fire performance when in a similar configuration; and it is the responsibility of the building occupants/owner to ensure that this is the case.

This Report is provided to the sponsor on the basis that it is a professional independent engineering evaluation as to what the fire performance of the construction/system would be should it to be tested to the named standard. It is KFS's experience that such an evaluation is normally acceptable in support of an application for building approvals, certainly throughout the UK and in many parts of Europe and the rest of the world.

However, unless KFS have been commissioned to liaise with the Authorities that have jurisdiction for the building in question for the purpose of obtaining the necessary approvals, KFS cannot assure that the document will satisfy the requirements of the particular building regulations for any building being constructed.

It is, therefore, the responsibility of the sponsor to establish whether this evidence is appropriate for the application for which it is being supplied and KFS cannot take responsibility for any costs incurred as a result of any rejection of the document for reasons outside of our control. Early submittal of the Report to the Authorities will minimise any risks in this respect.

10. Validity

This Field of Application Report has been prepared based on Kiwa Fire Safety Compliance's present knowledge of the products described, the stated testing regime and the submitted test evidence.

The assessment is valid initially for a period of five years after which time it is recommended that it be submitted to Kiwa Fire Safety Compliance for re-evaluation. For this reason, anyone using this document after 21th October 2030 should confirm its ongoing validity.

This assessment report is not valid unless it incorporates the declaration, in Section 5, duly signed by the applicant.

Prepared by:



Chris Avery

TIFireE ACABE

Senior Fire Safety Engineer

Kiwa Fire Safety Compliance

(part of the Kiwa UK Group)

Reviewed by:



Will Lightfoot

BEng (Hons) MSc C.Build E MCABE AIFireE

Associate Director of Product Evaluation

Kiwa Fire Safety Compliance

(part of the Kiwa UK Group)

11. Declaration by the Applicant

KFS Field of Application Report	PAR/10341/01 Revision C
Client	Halspan Ltd
We the undersigned confirm that we have read and complied with the obligations placed on us by the	
Passive Fire Protection Forum (PFPF) - Industry Standard Procedure 2021 'Guide to Undertaking Technical Assessments of Fire Performance of Construction Products Based on Fire Test Evidence'	
<ul style="list-style-type: none"> We confirm that any changes which are subject of this assessment have not to our knowledge been tested to the standard against which this assessment has been made. We agree to withdraw this assessment from circulation should the component or element of structure, or any of its component parts be the subject of a failed fire resistance test to the standard against which this assessment is being made. We understand that this assessment is based on test evidence and will be withdrawn should evidence become available that causes the conclusion to be questioned. In that case, we accept that new test evidence may be required. We are not aware of any information that could affect the conclusions of this assessment. If we subsequently become aware of any such information, we agree to ask the assessing authority to withdraw the assessment. 	
Signature	
Name	
Position	
Company Name	Halspan Ltd
Date	

Appendix A – Approved Leaf Envelopes and Intumescent Seal Specifications for 44mm Thick Optima FD30 Doors in SOFTWOOD/HARDWOOD Frames

CONFIGURATION DESCRIPTION	CONFIGURATION CODE
Latched, Single Acting, Single Leaf / Optional transomed overpanel only	LSASD
Unlatched, Single Acting, Single Leaf / Optional transomed overpanel only	ULSASD
Double Acting, Single Leaf / Optional transomed overpanel only	DASD
Latched, Single Acting, Single Leaf with Flush Overpanel	LSASD+OP
Unlatched, Single Acting, Single Leaf with Flush Overpanel	ULSASD+OP
Double Acting, Single Leaf with Flush Overpanel	DASD+OP
Latched, Single Acting, Double Leaf / Optional transomed overpanel only	LSADD
Unlatched, Single Acting, Double Leaf / Optional transomed overpanel only	ULSADD
Double Acting, Double Leaf / Optional transomed overpanel only	DADD
Latched, Single Acting, Double Leaf with Flush Overpanel	LSADD+OP
Unlatched, Single Acting, Double Leaf with Flush Overpanel	ULSADD+OP
Double Acting, Double Leaf with Flush Overpanel	DADD+OP

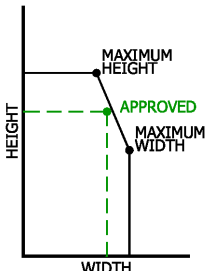
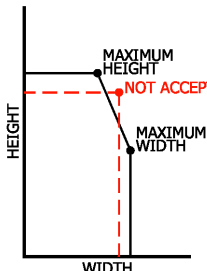
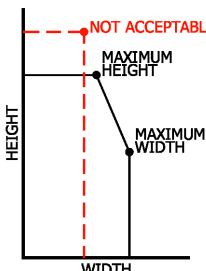
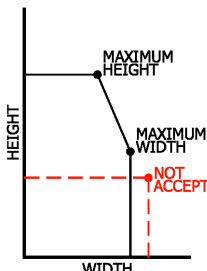
A.1 Approved Leaf Envelope A.01

REDUCED INTUMESCENT SPECIFICATION

FIGURE: A.01.1		LEAF CONFIGURATION: LATCHED, SINGLE ACTING, SINGLE DOOR	
DOOR CONSTRUCTION OPTIONS			
44mm Halspan Optima			
FRAME MATERIAL			
Softwood or Hardwood			
LIPPING TYPES			
L30/1, L30/8			
MEETING STILE JUNCTION			
N/A			
OVERPANEL JUNCTION			
N/A			
LEAF ENVELOPE			
HEIGHT	WIDTH		
2128mm	951mm		
2346mm	863mm		
FIRE TEST EVIDENCE			
RF01056			
INTUMESCENT SPECIFICATION - REDUCED			
HEAD	FRAME	1no 10 x 4mm thick intumescent seal positioned centrally to the leaf thickness	
VERTICAL EDGES	FRAME	1no 10 x 4mm thick intumescent seal positioned centrally to the leaf thickness	

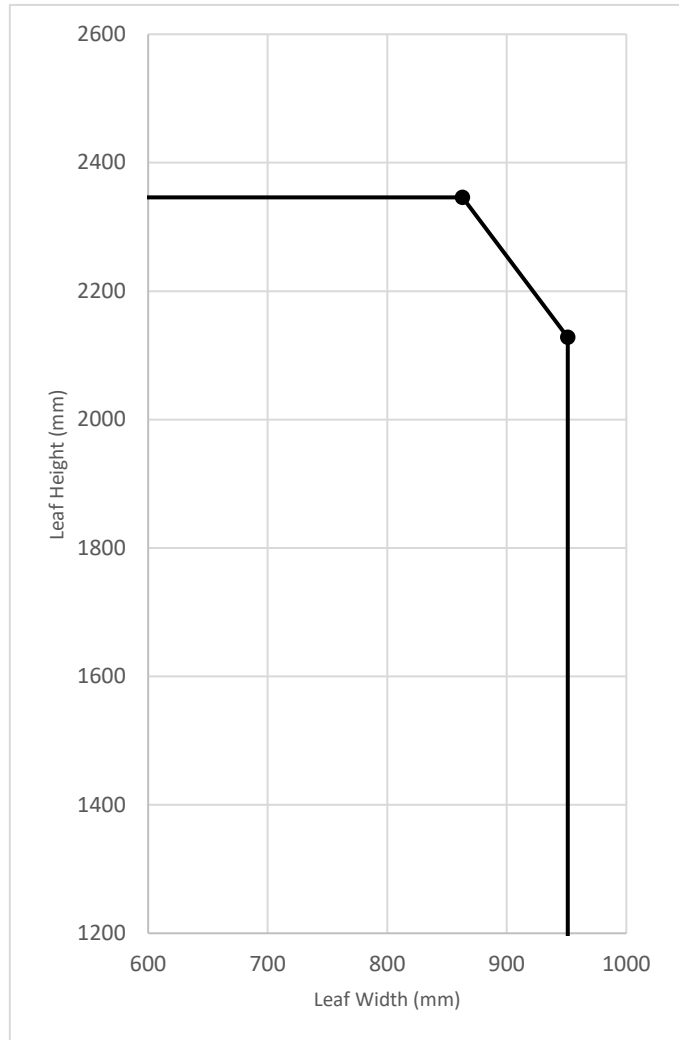

STANDARD INTUMESCENT SPECIFICATION

FIGURE: A.01.2		LEAF CONFIGURATION: LATCHED, SINGLE ACTING, SINGLE DOOR	
DOOR CONSTRUCTION OPTIONS			
44mm Halspan Optima			
FRAME MATERIAL			
Softwood or Hardwood			
LIPPING TYPES			
L30/1, L30/8			
MEETING STILE JUNCTION			
N/A			
OVERPANEL JUNCTION			
N/A			
LEAF ENVELOPE			
HEIGHT	WIDTH		
2123mm	972mm		
2194mm	940mm		
FIRE TEST EVIDENCE			
RF06068			
INTUMESCENT SPECIFICATION - STANDARD			
HEAD	FRAME	1no 15 x 4mm thick intumescent seal positioned centrally to the leaf thickness	
VERTICAL EDGES	FRAME	1no 15 x 4mm thick intumescent seal positioned centrally to the leaf thickness	

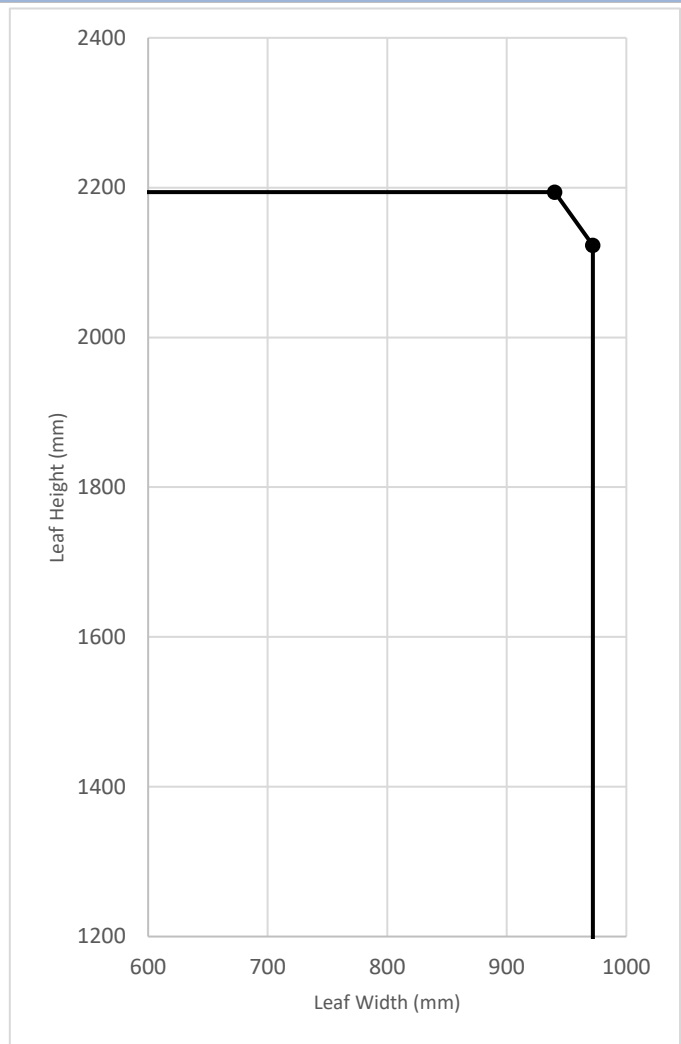

CONCEALED INTUMESCENT SPECIFICATION

FIGURE: A.01.3		LEAF CONFIGURATION: LATCHED, SINGLE ACTING, SINGLE DOOR	
DOOR CONSTRUCTION OPTIONS			
44mm Halspan Optima			
FRAME MATERIAL			
Hardwood only			
LIPPING TYPES			
L30/1			
MEETING STILE JUNCTION			
N/A			
OVERPANEL JUNCTION			
N/A			
LEAF ENVELOPE			
HEIGHT		WIDTH	
2819mm		1052mm	
3107mm		954mm	
FIRE TEST EVIDENCE			
RF00068			
INTUMESCENT SPECIFICATION - CONCEALED			
HEAD	FRAME	1no 20 x 4mm thick intumescent seal positioned centrally in the frame reveal	
VERTICAL EDGES	LEAF	1no 30 x 2mm thick Lorient Polyproducts 100EC centrally grooved into the rear face of the lipping	

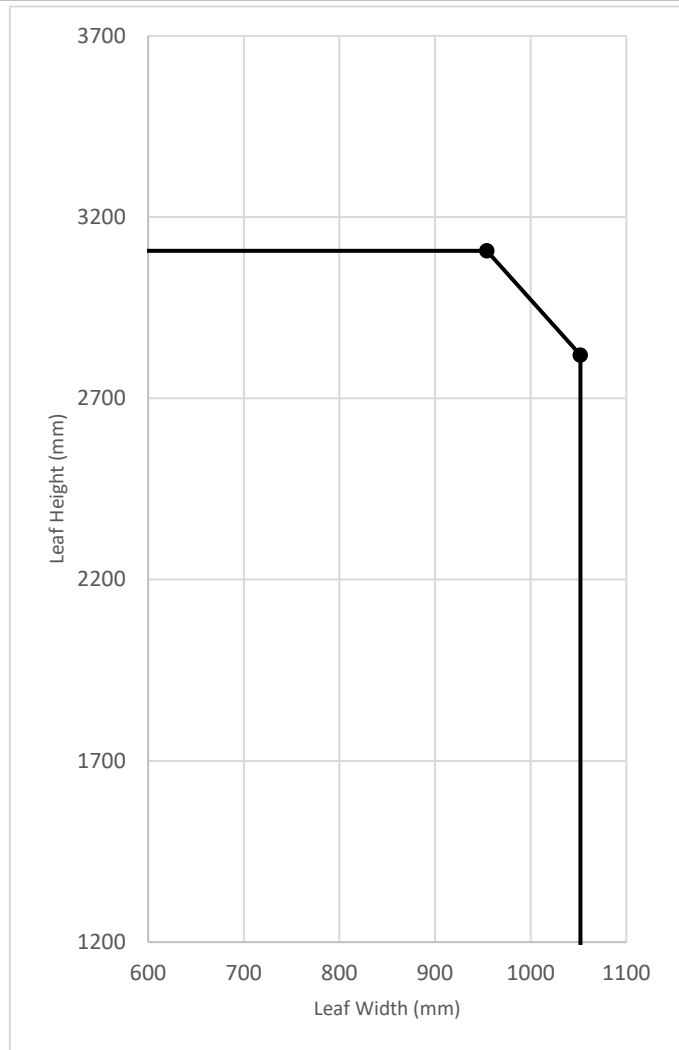

A.2 Approved Leaf Envelope A.02

REDUCED INTUMESCENT SPECIFICATION

FIGURE: A.02.1		LEAF CONFIGURATION: UNLATCHED, SINGLE ACTING, SINGLE DOOR	
DOOR CONSTRUCTION OPTIONS			
44mm Halspan Optima			
FRAME MATERIAL			
Softwood or Hardwood			
LIPPING TYPES			
L30/1, L30/8			
MEETING STILE JUNCTION			
N/A			
OVERPANEL JUNCTION			
N/A			
LEAF ENVELOPE			
HEIGHT		WIDTH	
2128mm		951mm	
2346mm		863mm	
FIRE TEST EVIDENCE			
RF01056			
INTUMESCENT SPECIFICATION			
HEAD	FRAME	1no 10 x 4mm thick intumescent seal positioned centrally to the leaf thickness	
VERTICAL EDGES	FRAME	1no 10 x 4mm thick intumescent seal positioned centrally to the leaf thickness	

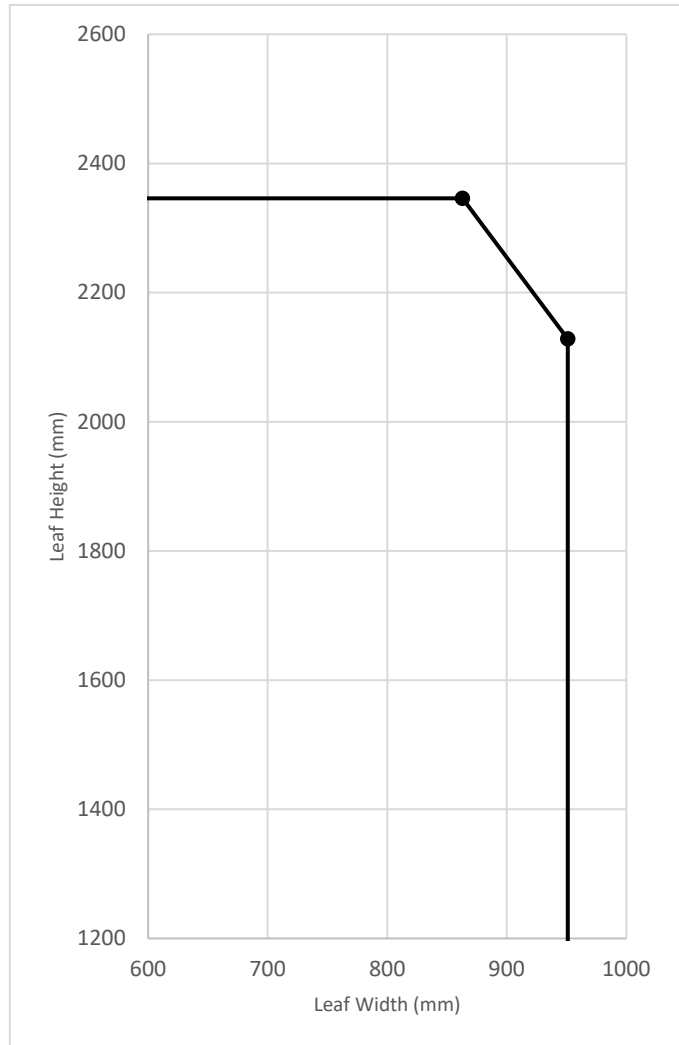

STANDARD INTUMESCENT SPECIFICATION

FIGURE: A.02.2		LEAF CONFIGURATION: UNLATHCED, SINGLE ACTING, SINGLE DOOR	
DOOR CONSTRUCTION OPTIONS			
44mm Halspan Optima			
FRAME MATERIAL			
Softwood or Hardwood			
LIPPING TYPES			
L30/1, L30/8			
MEETING STILE JUNCTION			
N/A			
OVERPANEL JUNCTION			
N/A			
LEAF ENVELOPE			
HEIGHT		WIDTH	
2123mm		972mm	
2194mm		940mm	
FIRE TEST EVIDENCE			
RF06068			
INTUMESCENT SPECIFICATION - STANDARD			
HEAD	FRAME	1no 15 x 4mm thick intumescent seal positioned centrally to the leaf thickness	
VERTICAL EDGES	FRAME	1no 15 x 4mm thick intumescent seal positioned centrally to the leaf thickness	

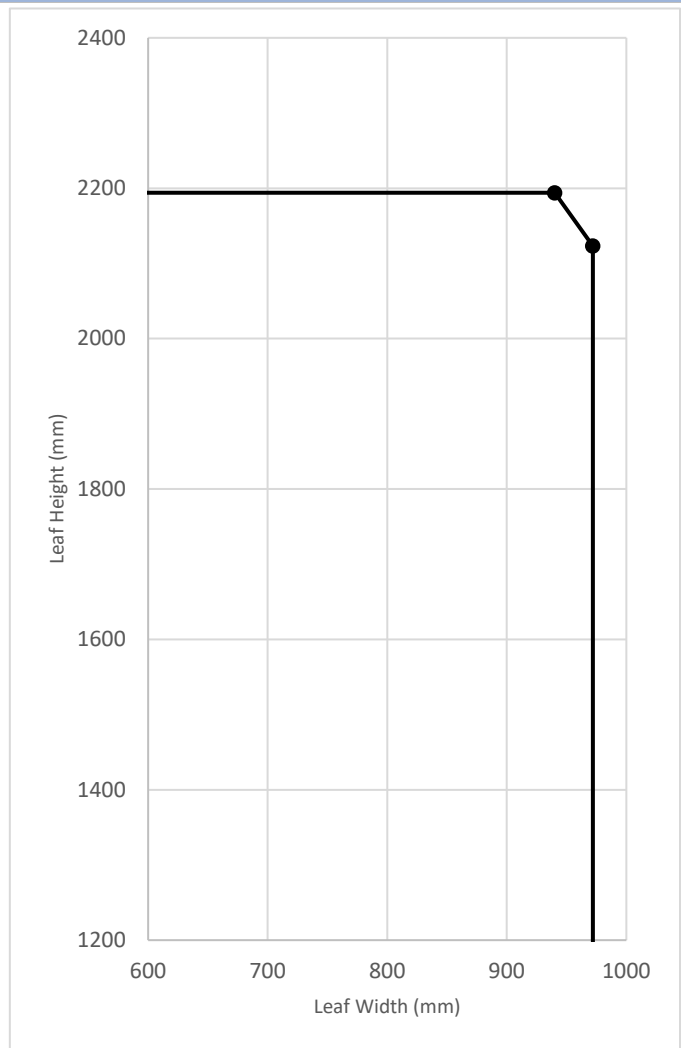

CONCEALED INTUMESCENT SPECIFICATION

FIGURE: A.02.3		LEAF CONFIGURATION: UNLATHCED, SINGLE ACTING, SINGLE DOOR	
DOOR CONSTRUCTION OPTIONS			
44mm Halspan Optima			
FRAME MATERIAL			
Hardwood only			
LIPPING TYPES			
L30/1			
MEETING STILE JUNCTION			
N/A			
OVERPANEL JUNCTION			
N/A			
LEAF ENVELOPE			
HEIGHT		WIDTH	
2819mm		1052mm	
3107mm		954mm	
FIRE TEST EVIDENCE			
RF00068			
INTUMESCENT SPECIFICATION			
HEAD	FRAME	1no 20 x 4mm thick intumescent seal positioned centrally in the frame reveal	
VERTICAL EDGES	LEAF	1no 30 x 2mm thick Lorient Polyproducts 100EC centrally grooved into the rear face of the lipping	

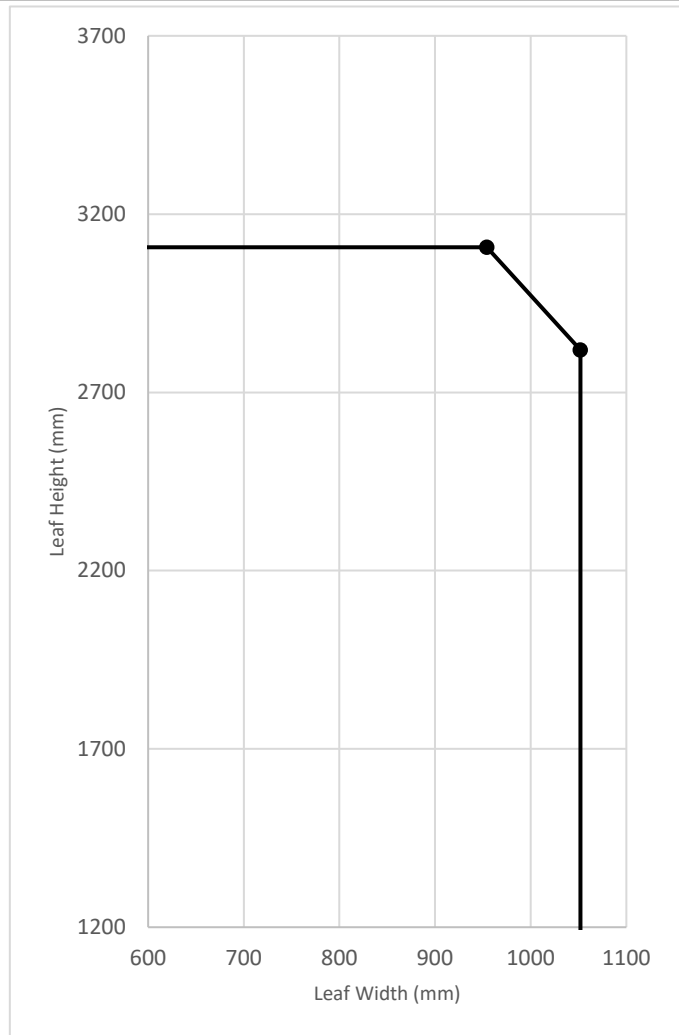

A.3 Approved Leaf Envelope A.03

FIGURE: A.03		LEAF CONFIGURATION: DOUBLE ACTING, SINGLE DOOR	
DOOR CONSTRUCTION OPTIONS			
44mm Halspan Optima			
FRAME MATERIAL			
Softwood or Hardwood			
LIPPING TYPES			
L30/1, L30/3, L30/4, L30/7			
MEETING STILE JUNCTION			
N/A			
OVERPANEL JUNCTION			
N/A			
LEAF ENVELOPE			
HEIGHT		WIDTH	
2128mm		1059mm	
2346mm		961mm	
FIRE TEST EVIDENCE			
WARRES 135011			
INTUMESCENT SPECIFICATION			
HEAD	FRAME	1no 10 x 4mm thick intumescent seal positioned centrally to the leaf thickness	
VERTICAL EDGES	FRAME	1no 10 x 4mm thick intumescent seal positioned centrally to the leaf thickness	

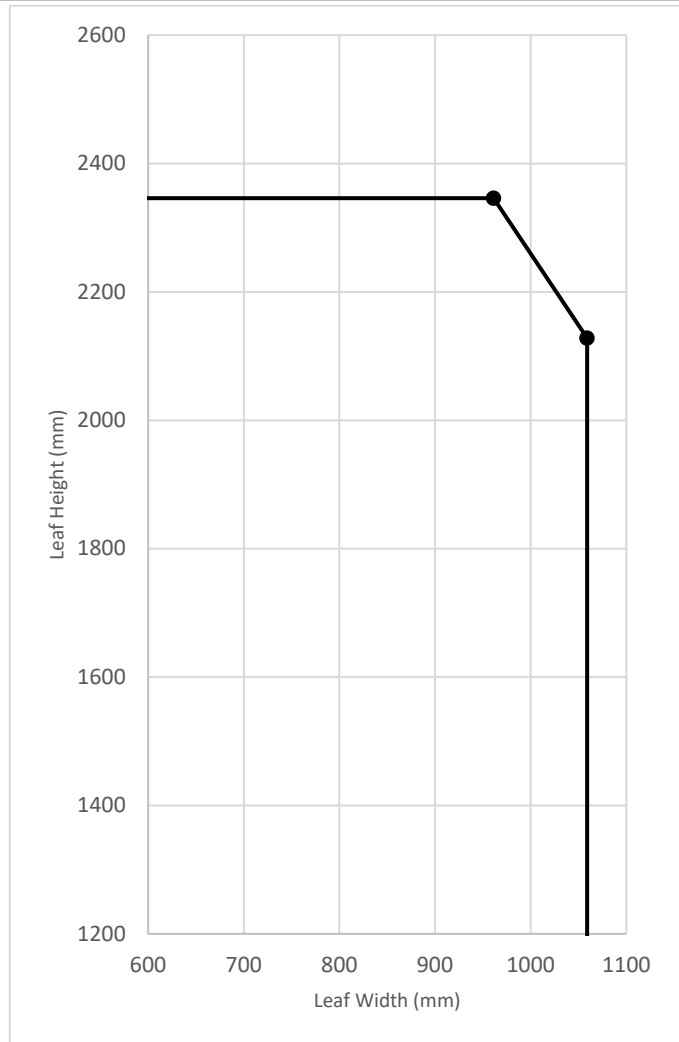

A.4 Approved Leaf Envelope A.04

SQUARE MEETING STILES, REDUCED INTUMESCENT SPECIFICATION

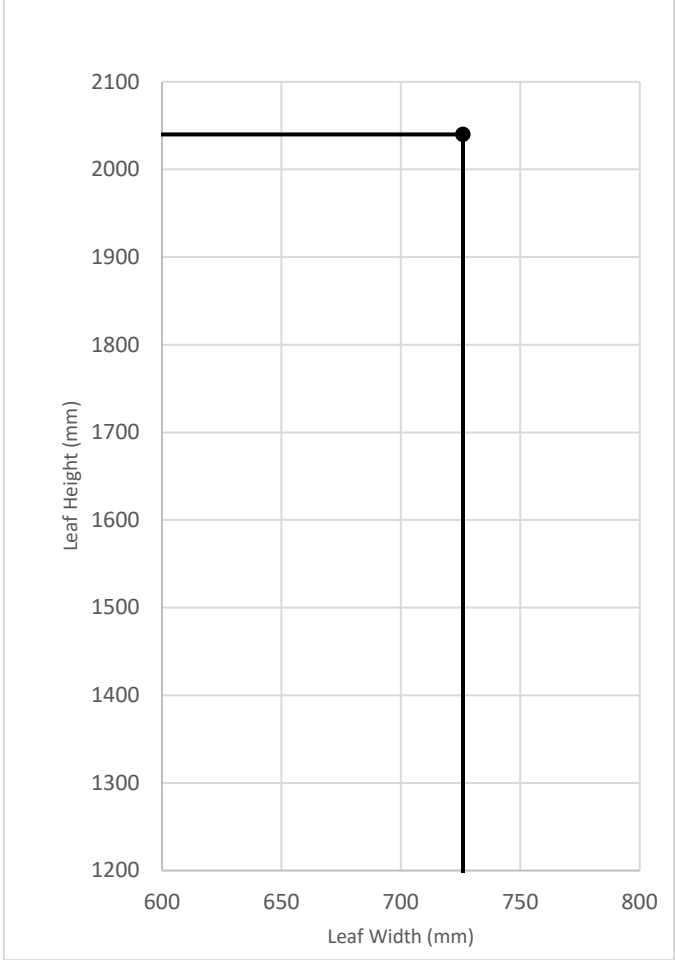
FIGURE: A.04.1		LEAF CONFIGURATION: LATCHED, SINGLE ACTING, DOUBLE DOOR	
DOOR CONSTRUCTION OPTIONS			
44mm Halspan Optima			
FRAME MATERIAL			
Softwood or Hardwood			
LIPPING TYPES			
L30/1			
MEETING STILE JUNCTION			
Square			
OVERPANEL JUNCTION			
N/A			
LEAF ENVELOPE			
HEIGHT	WIDTH		
2040mm	726mm		
FIRE TEST EVIDENCE			
WARRES 112248			
			
INTUMESCENT SPECIFICATION - REDUCED			
HEAD	FRAME	1no 10 x 4mm thick intumescent seal positioned centrally to the leaf thickness	
VERTICAL EDGES	FRAME	1no 10 x 4mm thick intumescent seal positioned centrally to the leaf thickness	
MEETING STILES	SQUARE	1no 10 x 4mm thick intumescent seal fitted into the leading edge of each leaf, centrally to the leaf thickness	

SQUARE MEETING STILES, STANDARD INTUMESCENT SPECIFICATION

FIGURE: A.04.2		LEAF CONFIGURATION: LATCHED, SINGLE ACTING, DOUBLE DOOR	
DOOR CONSTRUCTION OPTIONS			
44mm Halspan Optima			
FRAME MATERIAL			
Softwood or Hardwood			
LIPPING TYPES			
L30/1			
MEETING STILE JUNCTION			
Square			
OVERPANEL JUNCTION			
N/A			
LEAF ENVELOPE			
HEIGHT	WIDTH		
2144mm	1048mm		
2363mm	951mm		
FIRE TEST EVIDENCE			
RF08039			
INTUMESCENT SPECIFICATION - STANDARD			
HEAD	FRAME	1no 15 x 4mm thick intumescent seal positioned central to the leaf thickness	
VERTICAL EDGES	FRAME	1no 15 x 4mm thick intumescent seal positioned central to the leaf thickness	
MEETING STILES	SQUARE	1no 15 x 4mm thick intumescent seal fitted in the leading edge of each leaf, central to the leaf thickness	

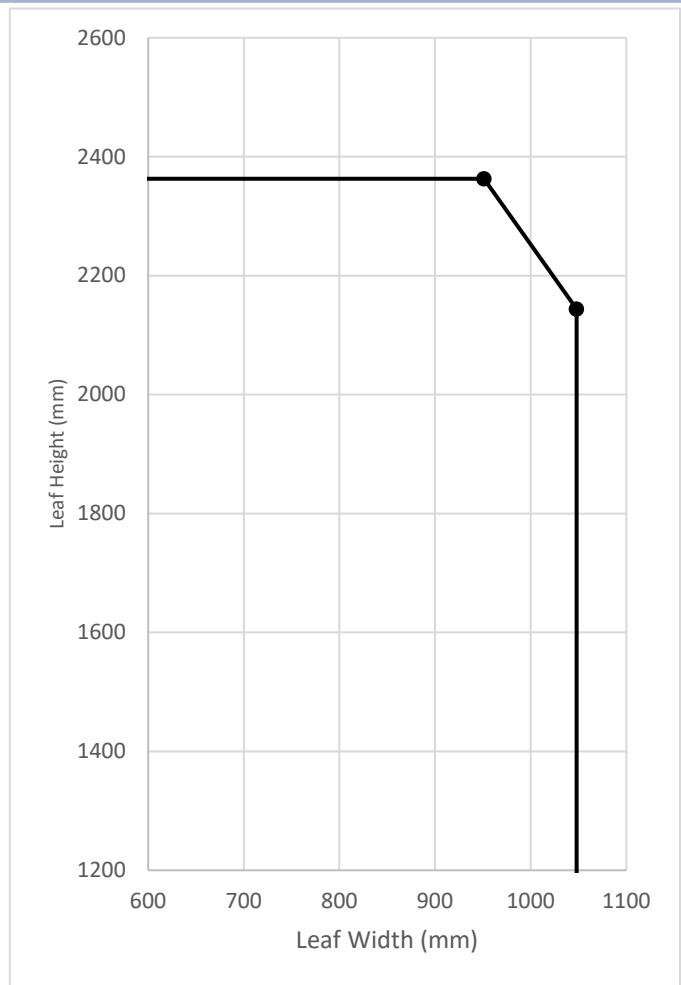

EQUALLY REBATED MEETING STILES

FIGURE: A.04.3	LEAF CONFIGURATION: LATCHED, SINGLE ACTING, DOUBLE DOOR
-------------------	--

DOOR CONSTRUCTION OPTIONS	
44mm Halspan Optima	
FRAME MATERIAL	
Softwood or Hardwood	
LIPPING TYPES	
L30/1, L30/2	
MEETING STILE JUNCTION	
Equally Rebated	
OVERPANEL JUNCTION	
N/A	
LEAF ENVELOPE	
HEIGHT	WIDTH
2072mm	966mm
2142mm	934mm
FIRE TEST EVIDENCE	
WARRES 131998 – Door B	

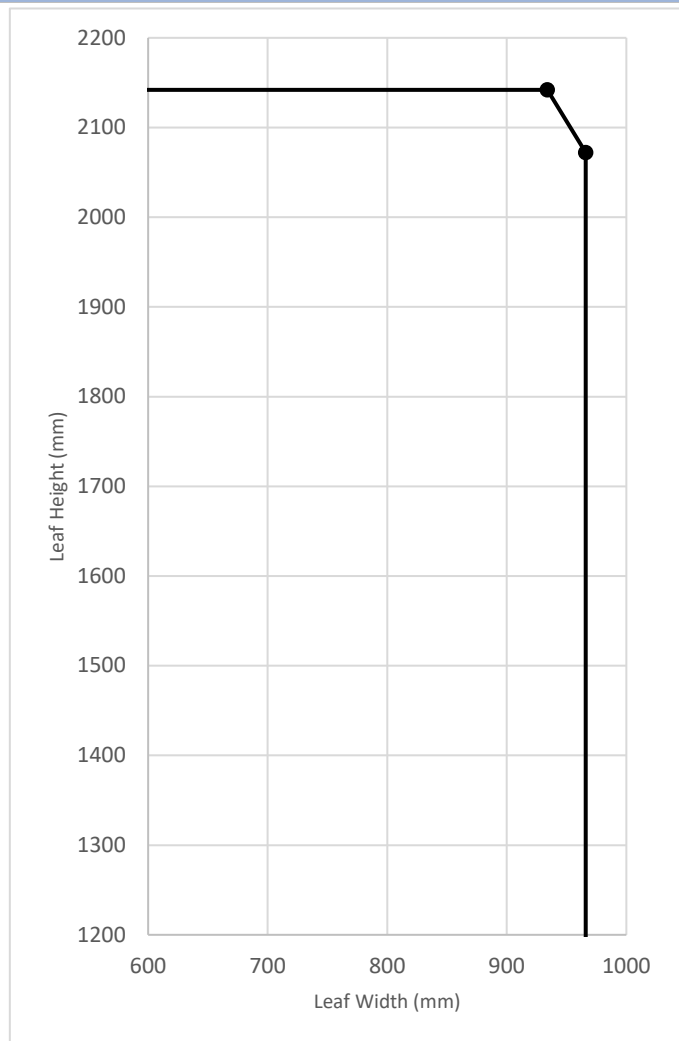

INTUMESCENT SPECIFICATION

HEAD	FRAME	1no 10 x 4mm thick intumescent seal, positioned centrally to the leaf thickness
VERTICAL EDGES	FRAME	1no 10 x 4mm thick intumescent seal, positioned centrally to the leaf thickness
MEETING STILES	EQUALLY REBATED	1no 10 x 4mm thick intumescent seal in both leaves, located centrally in each rebate interface

UNEQUALLY REBATED MEETING STILES

FIGURE: A.04.4	LEAF CONFIGURATION: LATCHED, SINGLE ACTING, DOUBLE DOOR
-------------------	--

DOOR CONSTRUCTION OPTIONS	
44mm Halspan Optima	
FRAME MATERIAL	
Softwood or Hardwood	
LIPPING TYPES	
L30/1, L30/2	
MEETING STILE JUNCTION	
Unequally Rebated	
OVERPANEL JUNCTION	
N/A	
LEAF ENVELOPE	
HEIGHT	WIDTH
2072mm	966mm
2142mm	934mm
FIRE TEST EVIDENCE	
WARRES 131998 – Door B	

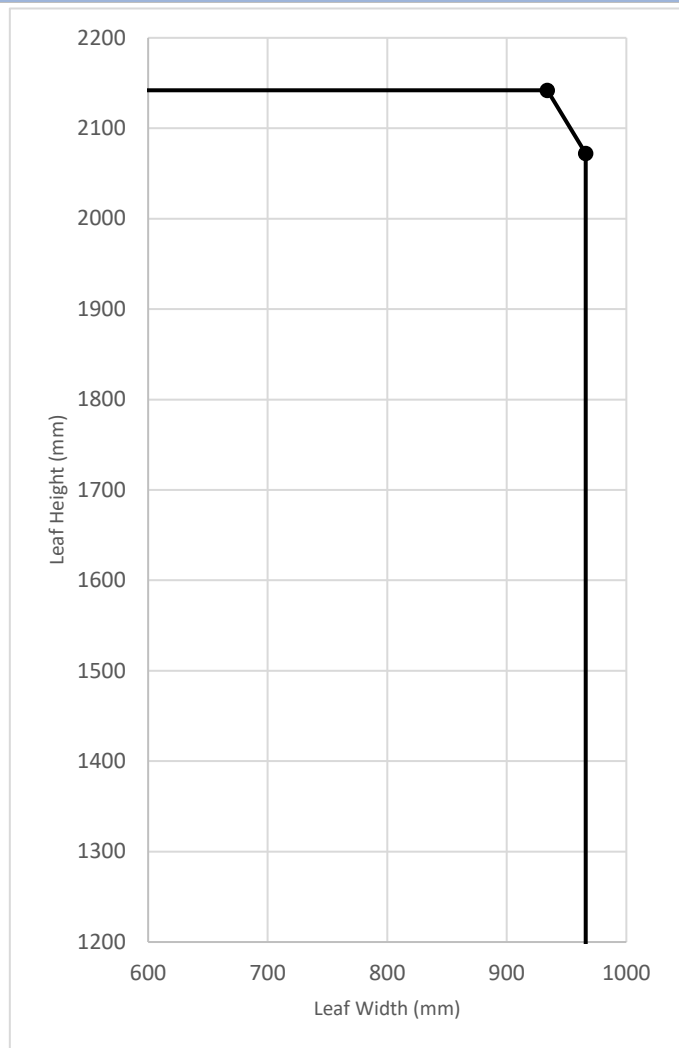

INTUMESCENT SPECIFICATION

HEAD	FRAME	1no 10 x 4mm thick intumescent seal, positioned centrally to the leaf thickness
VERTICAL EDGES	FRAME	1no 10 x 4mm thick intumescent seal, positioned centrally to the leaf thickness
MEETING STILES	UNEQUALLY REBATED	1no 10 x 4mm thick intumescent seal in both leaves, located centrally in each rebate interface

RADIUSED MEETING STILES

FIGURE: A.04.5		LEAF CONFIGURATION: LATCHED, SINGLE ACTING, DOUBLE DOOR	
DOOR CONSTRUCTION OPTIONS			
44mm Halspan Optima			
FRAME MATERIAL			
Softwood or Hardwood			
LIPPING TYPES			
L30/1, L30/3			
MEETING STILE JUNCTION			
Radiused			
OVERPANEL JUNCTION			
N/A			
LEAF ENVELOPE			
HEIGHT		WIDTH	
2128mm		1059mm	
2346mm		961mm	
FIRE TEST EVIDENCE			
WARRES 135011			
INTUMESCENT SPECIFICATION			
HEAD	FRAME	1no 10 x 4mm thick intumescent seal, positioned centrally to the leaf thickness	
VERTICAL EDGES	FRAME	1no 10 x 4mm thick intumescent seal, positioned centrally to the leaf thickness	
MEETING STILES	RADIUSED	1no 10 x 4mm thick intumescent seal in each leaf, positioned centrally to the leaf thickness	

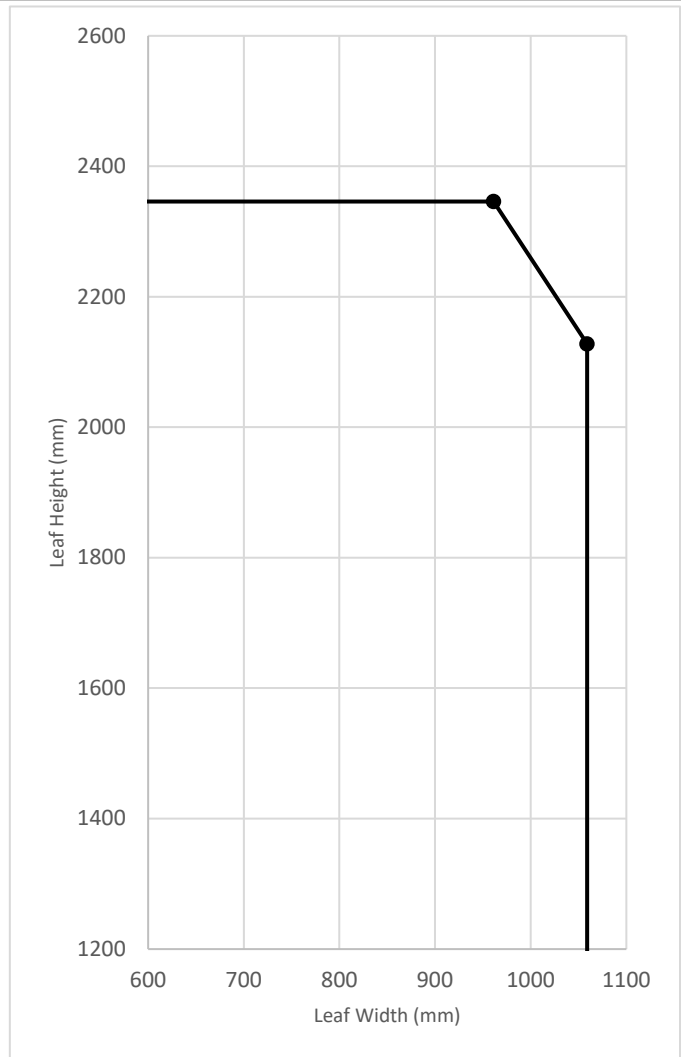

A.5 Approved Leaf Envelope A.05

SQUARE MEETING STILES, REDUCED INTUMESCENT

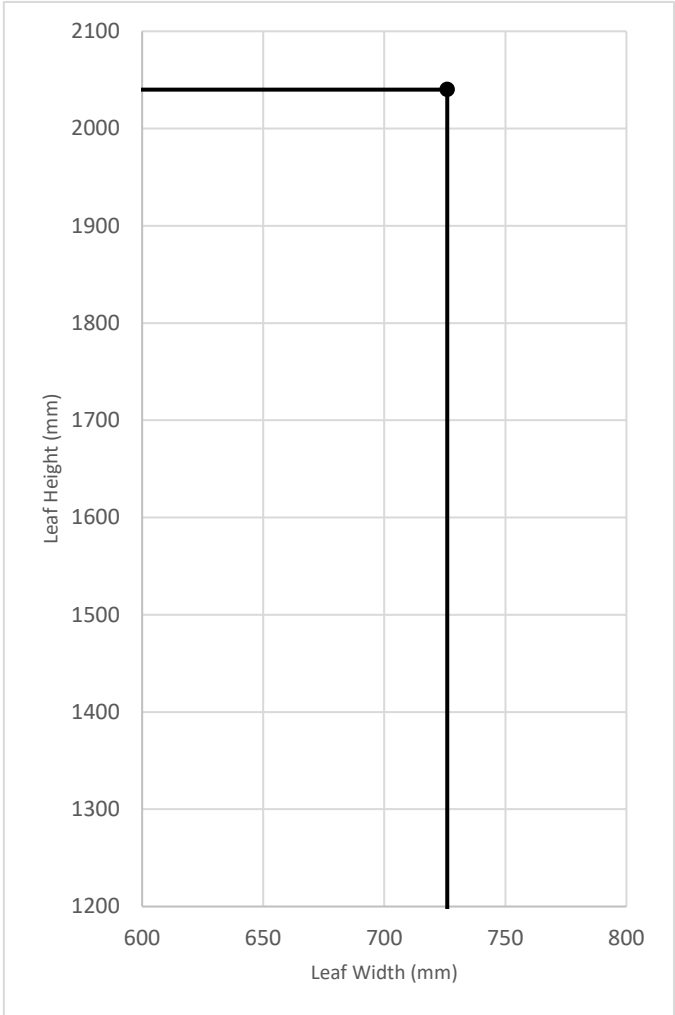
FIGURE: A.05.1		LEAF CONFIGURATION: UNLATCHED, SINGLE ACTING, DOUBLE DOOR	
DOOR CONSTRUCTION OPTIONS			
44mm Halspan			
FRAME MATERIAL			
Softwood or Hardwood			
LIPPING TYPES			
L30/1			
MEETING STILE JUNCTION			
Square			
OVERPANEL JUNCTION			
N/A			
LEAF ENVELOPE			
HEIGHT		WIDTH	
2040mm		726mm	
FIRE TEST EVIDENCE			
WARRES 112248			
			
INTUMESCENT SPECIFICATION - REDUCED			
HEAD	FRAME	1no 10 x 4mm thick intumescent seal positioned centrally to the leaf thickness	
VERTICAL EDGES	FRAME	1no 10 x 4mm thick intumescent seal positioned centrally to the leaf thickness	
MEETING STILES	SQUARE	1no 10 x 4mm thick intumescent seal fitted into the leading edge of each leaf, centrally to the leaf thickness	

SQUARE MEETING STILES, STANDARD INTUMESCENT

FIGURE: A.05.2		LEAF CONFIGURATION: UNLATCHED, SINGLE ACTING, DOUBLE DOOR	
DOOR CONSTRUCTION OPTIONS			
44mm Halspan			
FRAME MATERIAL			
Softwood or Hardwood			
LIPPING TYPES			
L30/1			
MEETING STILE JUNCTION			
Square			
OVERPANEL JUNCTION			
N/A			
LEAF ENVELOPE			
HEIGHT	WIDTH		
2144mm	1048mm		
2363mm	951mm		
FIRE TEST EVIDENCE			
RF08039			
INTUMESCENT SPECIFICATION - STANDARD			
HEAD	FRAME	1no 15 x 4mm thick intumescent seal, positioned centrally to the leaf thickness	
VERTICAL EDGES	FRAME	1no 15 x 4mm thick intumescent seal, positioned centrally to the leaf thickness	
MEETING STILES	SQUARE	1no 15 x 4mm thick intumescent seal, positioned centrally to the leaf thickness in the passive leaf edge	

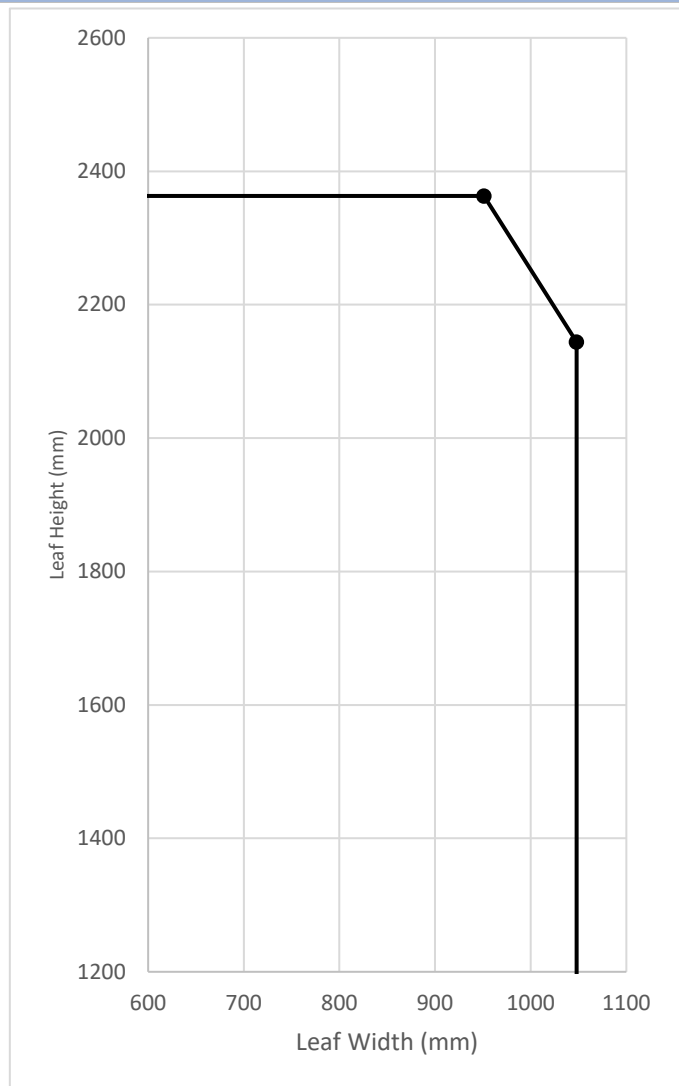

EQUALLY REBATED MEETING STILES

FIGURE: A.05.3		LEAF CONFIGURATION: UNLATCHED, SINGLE ACTING, DOUBLE DOOR	
DOOR CONSTRUCTION OPTIONS			
44mm Halspan			
FRAME MATERIAL			
Softwood or Hardwood			
LIPPING TYPES			
L30/1, L30/2			
MEETING STILE JUNCTION			
Equally Rebated			
OVERPANEL JUNCTION			
N/A			
LEAF ENVELOPE			
HEIGHT		WIDTH	
2072mm		966mm	
2142mm		934mm	
FIRE TEST EVIDENCE			
WARRES 131998 – Door B			
INTUMESCENT SPECIFICATION			
HEAD	FRAME	1no 10 x 4mm thick intumescent seal, positioned centrally to the leaf thickness	
VERTICAL EDGES	FRAME	1no 10 x 4mm thick intumescent seal, positioned centrally to the leaf thickness	
MEETING STILES	EQUALLY REBATED	1no 10 x 4mm thick intumescent seal in both leaves, located centrally in each rebate interface	

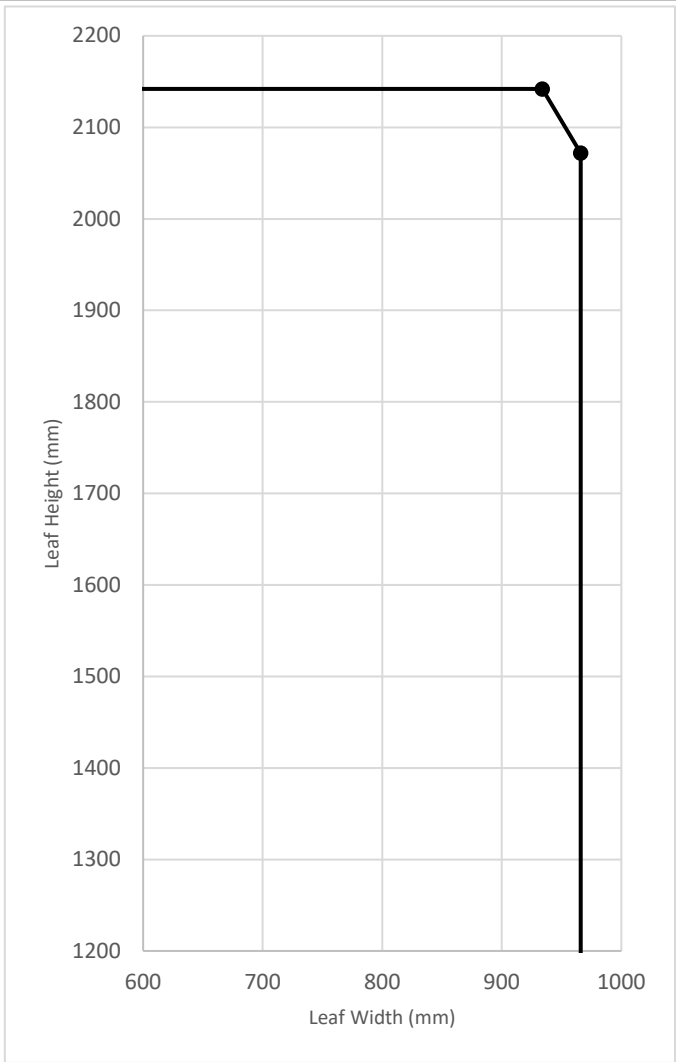

UNEQUALLY REBATED MEETING STILES

FIGURE: A.05.4		LEAF CONFIGURATION: UNLATCHED, SINGLE ACTING, DOUBLE DOOR	
DOOR CONSTRUCTION OPTIONS			
44mm Halspan			
FRAME MATERIAL			
Softwood or Hardwood			
LIPPING TYPES			
L30/1, L30/2			
MEETING STILE JUNCTION			
Unequally Rebated			
OVERPANEL JUNCTION			
N/A			
LEAF ENVELOPE			
HEIGHT		WIDTH	
2072mm		966mm	
2142mm		934mm	
FIRE TEST EVIDENCE			
WARRES 131998 – Door B			
INTUMESCENT SPECIFICATION			
HEAD	FRAME	1no 10 x 4mm thick intumescent seal, positioned centrally to the leaf thickness	
VERTICAL EDGES	FRAME	1no 10 x 4mm thick intumescent seal, positioned centrally to the leaf thickness	
MEETING STILES	UNEQUALLY REBATED	1no 10 x 4mm thick intumescent seal in both leaves, located centrally in each rebate interface	

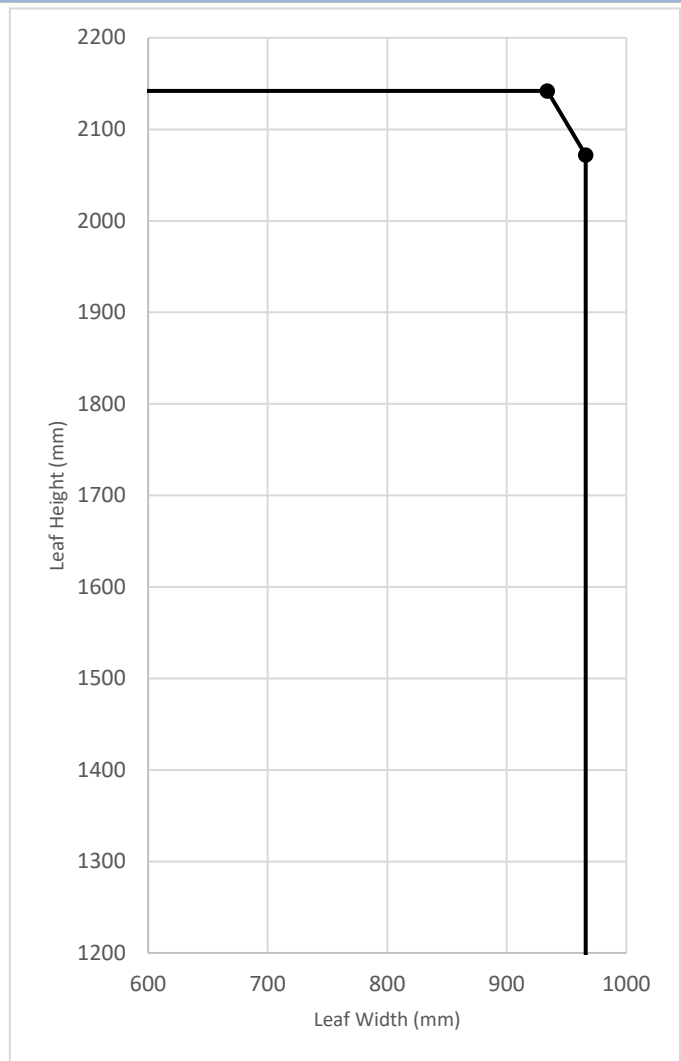

RADIUSED MEETING STILES

FIGURE:	LEAF CONFIGURATION:
A.05.5	UNLATCHED, SINGLE ACTING, DOUBLE DOOR

DOOR CONSTRUCTION OPTIONS	
44mm Halspan	
FRAME MATERIAL	
Softwood or Hardwood	
LIPPING TYPES	
L30/1, L30/3	
MEETING STILE JUNCTION	
Radiused	
OVERPANEL JUNCTION	
N/A	
LEAF ENVELOPE	
HEIGHT	WIDTH
2128mm	1059mm
2346mm	961mm
FIRE TEST EVIDENCE	
WARRES 135011	

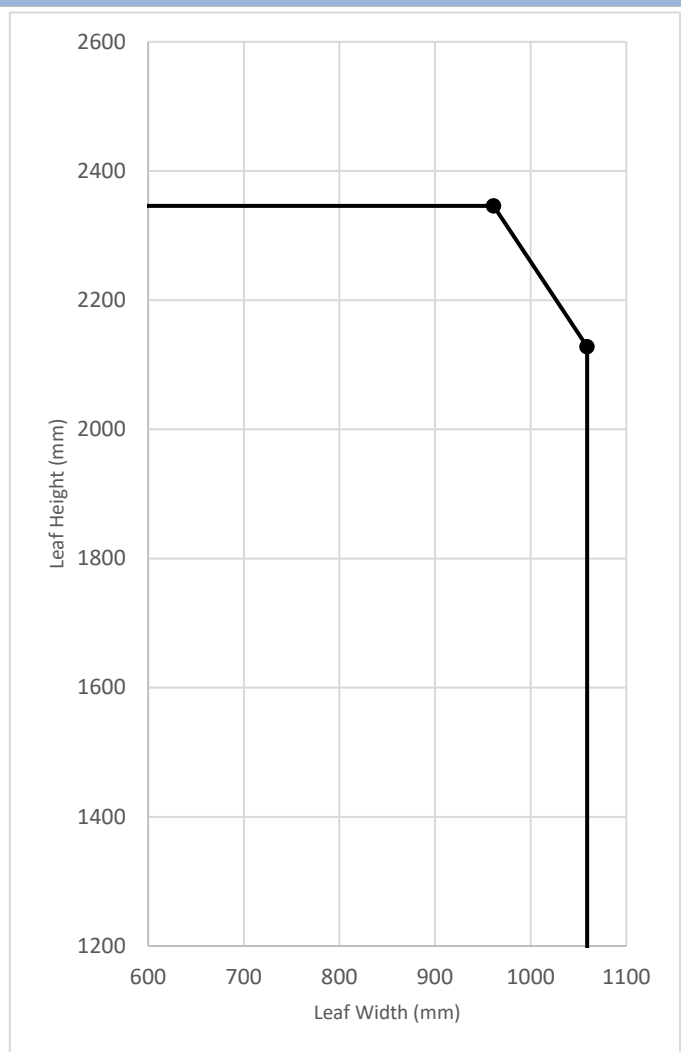

INTUMESCENT SPECIFICATION

HEAD	FRAME	1no 10 x 4mm thick intumescent seal, positioned centrally to the leaf thickness
VERTICAL EDGES	FRAME	1no 10 x 4mm thick intumescent seal, positioned centrally to the leaf thickness
MEETING STILES	RADIUSED	1no 10 x 4mm thick intumescent seal in each leaf, positioned centrally to the leaf thickness

A.6 Approved Leaf Envelope A.06

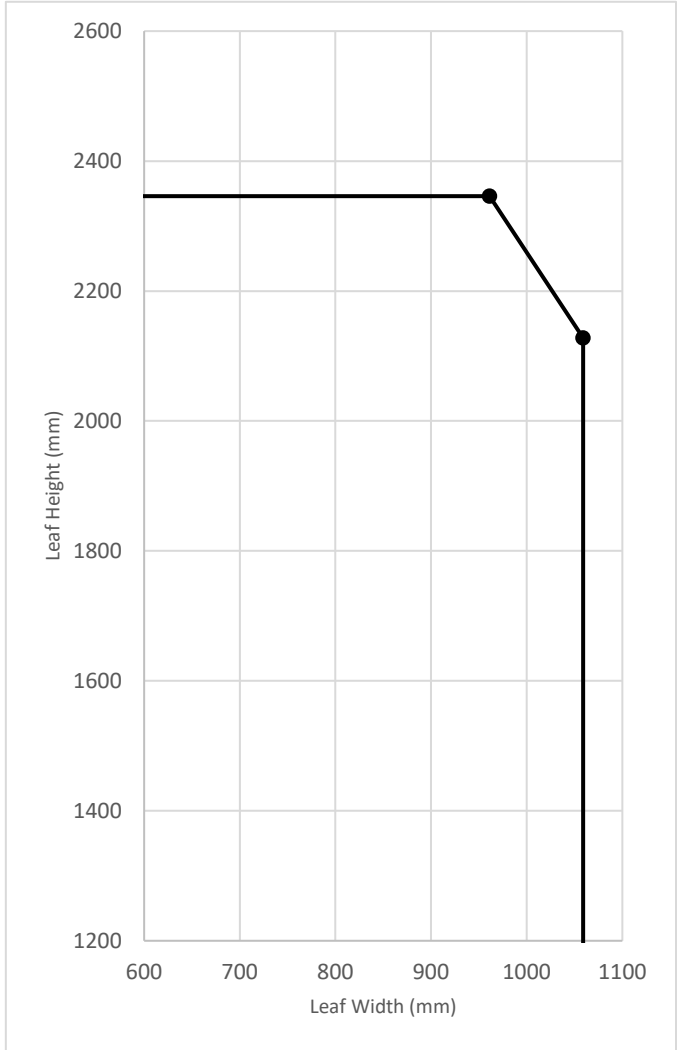
FIGURE:		LEAF CONFIGURATION:	
A.06		DOUBLE ACTING, DOUBLE DOOR	
DOOR CONSTRUCTION OPTIONS			
44mm Halspan Optima			
FRAME MATERIAL			
Softwood or Hardwood			
LIPPING TYPES			
L30/1, L30/3, L30/4, L30/5, L30/7			
MEETING STILE JUNCTION			
Square or Radiused			
OVERPANEL JUNCTION			
N/A			
LEAF ENVELOPE			
HEIGHT		WIDTH	
2128mm		1059mm	
2346mm		961mm	
FIRE TEST EVIDENCE			
WARRES 135011			
			
INTUMESCENT SPECIFICATION			
HEAD	FRAME	1no 10 x 4mm thick intumescent seal, positioned centrally to the leaf thickness	
VERTICAL EDGES	FRAME	1no 10 x 4mm thick intumescent seal, positioned centrally to the leaf thickness	
MEETING STILES	SQUARE OR RADIUSED	1no 10 x 4mm thick intumescent seal in each leaf, positioned centrally to the leaf thickness	

A.7 Approved Leaf Envelope A.07

REDUCED INTUMESCENT

FIGURE: A.07.1		LEAF CONFIGURATION: LATCHED, SINGLE ACTING, SINGLE DOOR, WITH TRANSOMED OVERPANEL	
DOOR CONSTRUCTION OPTIONS			
44mm Halspan Optima			
FRAME MATERIAL			
Softwood or Hardwood			
LIPPING TYPES			
L30/1, L30/8			
MEETING STILE JUNCTION			
N/A			
OVERPANEL JUNCTION			
Transomed			
LEAF ENVELOPE			
HEIGHT	WIDTH		
2072mm	966mm		
2142mm	934mm		
FIRE TEST EVIDENCE			
WARRES 131998 – Door B			
			
INTUMESCENT SPECIFICATION - REDUCED			
HEAD	FRAME	1no 10 x 4mm thick intumescent seal, positioned centrally to the leaf thickness	
VERTICAL EDGES	FRAME	1no 10 x 4mm thick intumescent seal, positioned centrally to the leaf thickness	
TRANSOMED OVERPANEL	OVERPANEL EDGES	1no 10 x 4mm thick intumescent seal, positioned centrally to the overpanel thickness	

STANDARD INTUMESCENT

FIGURE: A.07.2		LEAF CONFIGURATION: LATCHED, SINGLE ACTING, SINGLE DOOR, WITH TRANSOMED OVERPANEL	
DOOR CONSTRUCTION OPTIONS			
44mm Halspan Optima			
FRAME MATERIAL			
Softwood or Hardwood			
LIPPING TYPES			
L30/1, L30/8			
MEETING STILE JUNCTION			
N/A			
OVERPANEL JUNCTION			
Transomed			
LEAF ENVELOPE			
HEIGHT		WIDTH	
2227mm		1052mm	
2455mm		954mm	
FIRE TEST EVIDENCE			
RF13063			
INTUMESCENT SPECIFICATION - STANDARD			
HEAD	FRAME	1no 15 x 4mm thick intumescent seal, positioned centrally to the leaf thickness	
VERTICAL EDGES	FRAME	1no 15 x 4mm thick intumescent seal, positioned centrally to the leaf thickness	
TRANSOMED OVERPANEL	OVERPANEL EDGES	1no 15 x 4mm thick intumescent seal, positioned centrally to the overpanel thickness	

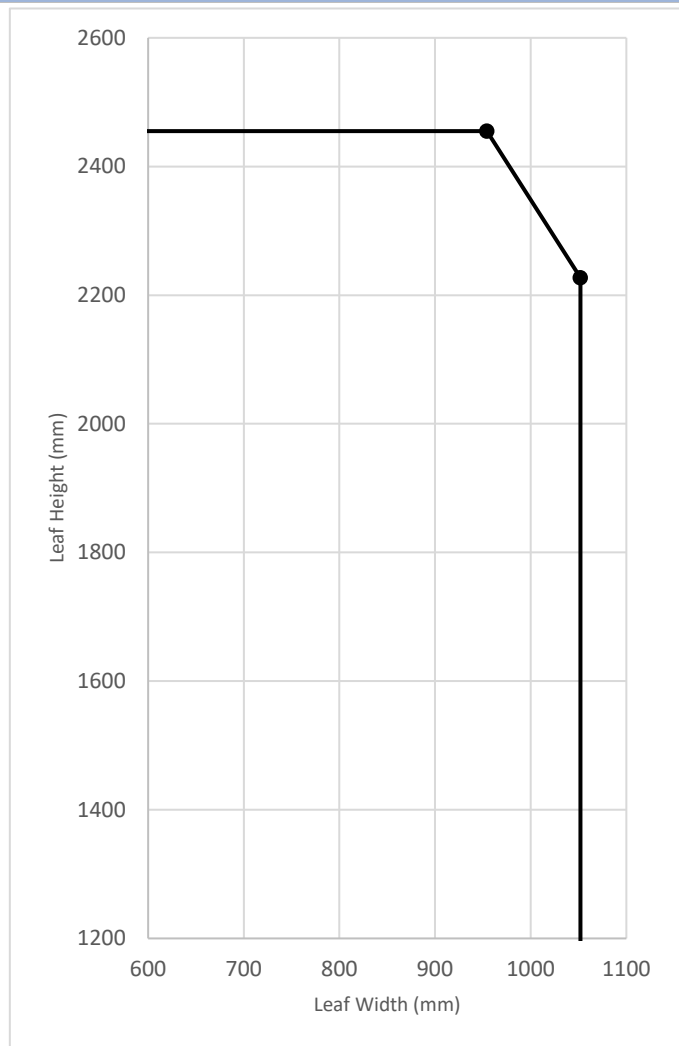

A.8 Approved Leaf Envelope A.08

REDUCED INTUMESCENT

FIGURE: A.08.1		LEAF CONFIGURATION: LATCHED, SINGLE ACTING, SINGLE DOOR, WITH SQUARE/REBATED OVERPANEL	
DOOR CONSTRUCTION OPTIONS			
44mm Halspan Optima			
FRAME MATERIAL			
Softwood or Hardwood			
LIPPING TYPES			
L30/1, L30/2			
MEETING STILE JUNCTION			
N/A			
OVERPANEL JUNCTION			
Square / Equally Rebated / Unequally rebated			
LEAF ENVELOPE			
HEIGHT	WIDTH		
2072mm	966mm		
2142mm	934mm		
FIRE TEST EVIDENCE			
WARRES 131998 – Door B			
INTUMESCENT SPECIFICATION - STANDARD			
HEAD	FRAME	1no 10 x 4mm thick intumescent seal, positioned centrally to the leaf thickness	
VERTICAL EDGES	FRAME	1no 10 x 4mm thick intumescent seal, positioned centrally to the leaf thickness	
OVERPANEL JUNCTION	EQUALLY REBATED EDGE	1no 10 x 4mm thick intumescent seal in both leaves, located centrally in each rebate interface	
	UNEQUALLY REBATED EDGE	1no 10 x 4mm thick intumescent seal in both leaves, located centrally in each rebate interface	
	SQUARE BOTTOM EDGE	2no 10 x 4mm seals spaced 10mm apart and positioned centrally to the leaf thickness	
	OVERPANEL EDGES – TOP AND VERTICAL	1no 10 x 4mm thick intumescent seal, positioned centrally to the overpanel thickness	

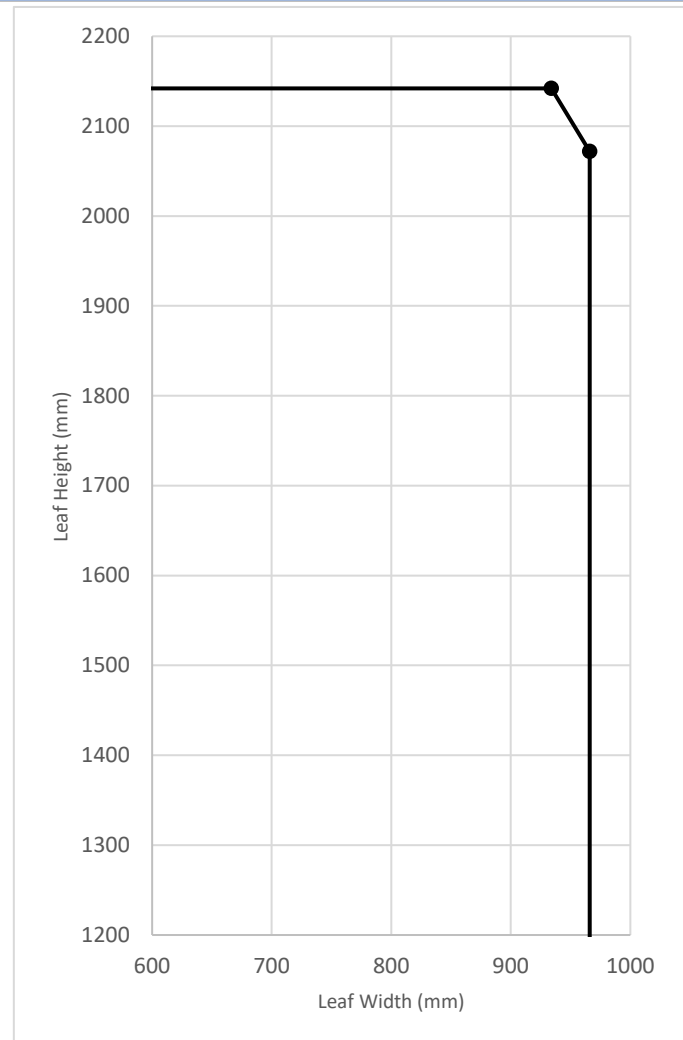

STANDARD INTUMESCENT SPEC

FIGURE: A.08.2		LEAF CONFIGURATION: LATCHED, SINGLE ACTING, SINGLE DOOR, WITH SQUARE/REBATED OVERPANEL	
DOOR CONSTRUCTION OPTIONS			
44mm Halspan Optima			
FRAME MATERIAL			
Softwood or Hardwood			
LIPPING TYPES			
L30/1, L30/2			
MEETING STILE JUNCTION			
N/A			
OVERPANEL JUNCTION			
Square/ Equally Rebated / Unequally rebated			
LEAF ENVELOPE			
HEIGHT		WIDTH	
2072mm		966mm	
2142mm		934mm	
FIRE TEST EVIDENCE			
RF13063			
INTUMESCENT SPECIFICATION - STANDARD			
HEAD	FRAME	1no 15 x 4mm thick intumescent seal, positioned centrally to the leaf thickness	
VERTICAL EDGES	FRAME	1no 15 x 4mm thick intumescent seal, positioned centrally to the leaf thickness	
OVERPANEL JUNCTION	EQUALLY REBATED EDGE	2no 15 x 4mm thick intumescent seals, one positioned centrally to the rebate in the leaf and overpanel interface	
	UNEQUALLY REBATED EDGE	2no 15 x 4mm thick intumescent seals, one positioned centrally to the rebate in the leaf and overpanel interface	
	SQUARE BOTTOM EDGE	2no 15 x 4mm thick intumescent seals, one positioned in the leaf 7mm from the opening face of the leaf and the other in the bottom edge of the overpanel 7mm from the closing face of the assembly.	
	OVERPANEL EDGES – TOP AND VERTICAL	1no 15 x 4mm thick intumescent seal, positioned centrally to the overpanel thickness	

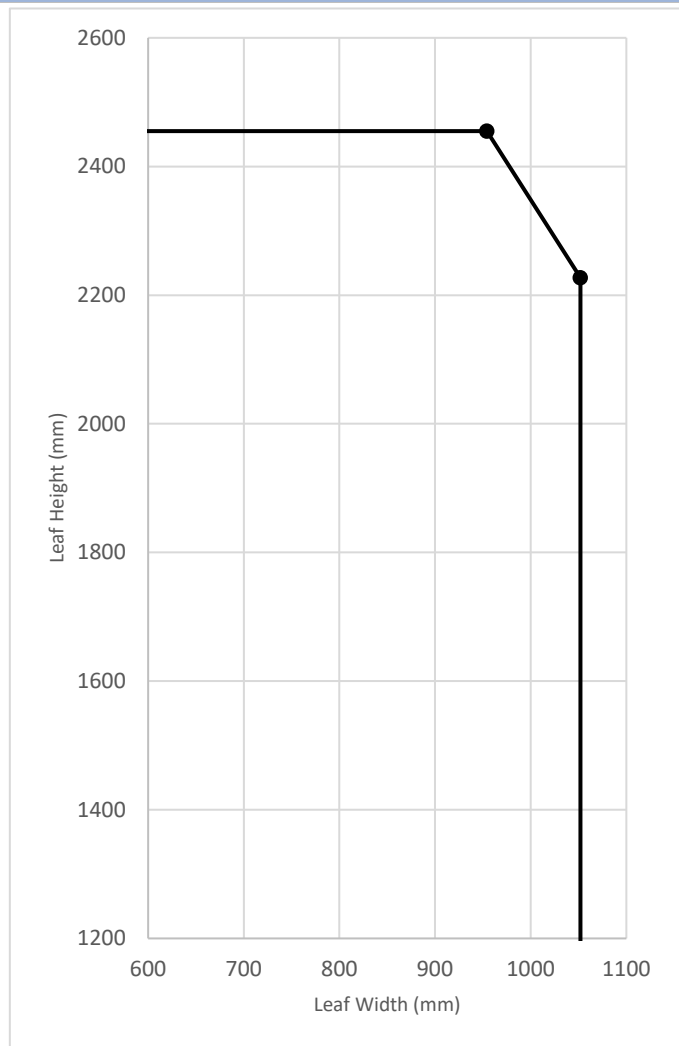

A.9 Approved Leaf Envelope A.09

REDUCED INTUMESCENT

FIGURE: A.09.1		LEAF CONFIGURATION: UNLATCHED, SINGLE ACTING, SINGLE DOOR, WITH TRANSOMED OVERPANEL	
DOOR CONSTRUCTION OPTIONS			
44mm Halspan Optima			
FRAME MATERIAL			
Softwood or Hardwood			
LIPPING TYPES			
L30/1, L30/8			
MEETING STILE JUNCTION			
N/A			
OVERPANEL JUNCTION			
Transomed			
LEAF ENVELOPE			
HEIGHT	WIDTH		
2072mm	966mm		
2142mm	934mm		
FIRE TEST EVIDENCE			
WARRES 131998 – Door B			
INTUMESCENT SPECIFICATION - REDUCED			
HEAD	FRAME	1no 10 x 4mm thick intumescent seal, positioned centrally to the leaf thickness	
VERTICAL EDGES	FRAME	1no 10 x 4mm thick intumescent seal, positioned centrally to the leaf thickness	
TRANSOMED OVERPANEL	OVERPANEL EDGES	1no 10 x 4mm thick intumescent seal, positioned centrally to the overpanel thickness	

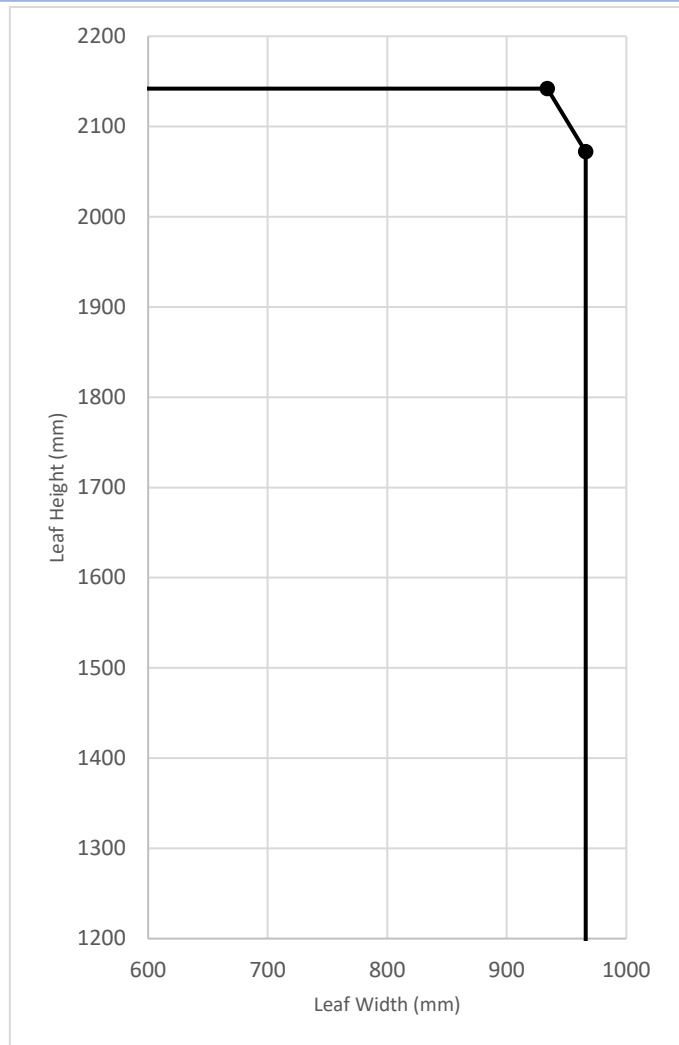

STANDARD INTUMESCENT

FIGURE: A.09.2		LEAF CONFIGURATION: UNLATCHED, SINGLE ACTING, SINGLE DOOR, WITH TRANSOMED OVERPANEL	
DOOR CONSTRUCTION OPTIONS			
44mm Halspan Optima			
FRAME MATERIAL			
Softwood or Hardwood			
LIPPING TYPES			
L30/1, L30/8			
MEETING STILE JUNCTION			
N/A			
OVERPANEL JUNCTION			
Transomed			
LEAF ENVELOPE			
HEIGHT		WIDTH	
2227mm		1052mm	
2455mm		954mm	
FIRE TEST EVIDENCE			
RF13063			
INTUMESCENT SPECIFICATION - STANDARD			
HEAD	FRAME	1no 15 x 4mm thick intumescent seal, positioned centrally to the leaf thickness	
VERTICAL EDGES	FRAME	1no 15 x 4mm thick intumescent seal, positioned centrally to the leaf thickness	
TRANSOMED OVERPANEL	OVERPANEL EDGES	1no 15 x 4mm thick intumescent seal, positioned centrally to the overpanel thickness	

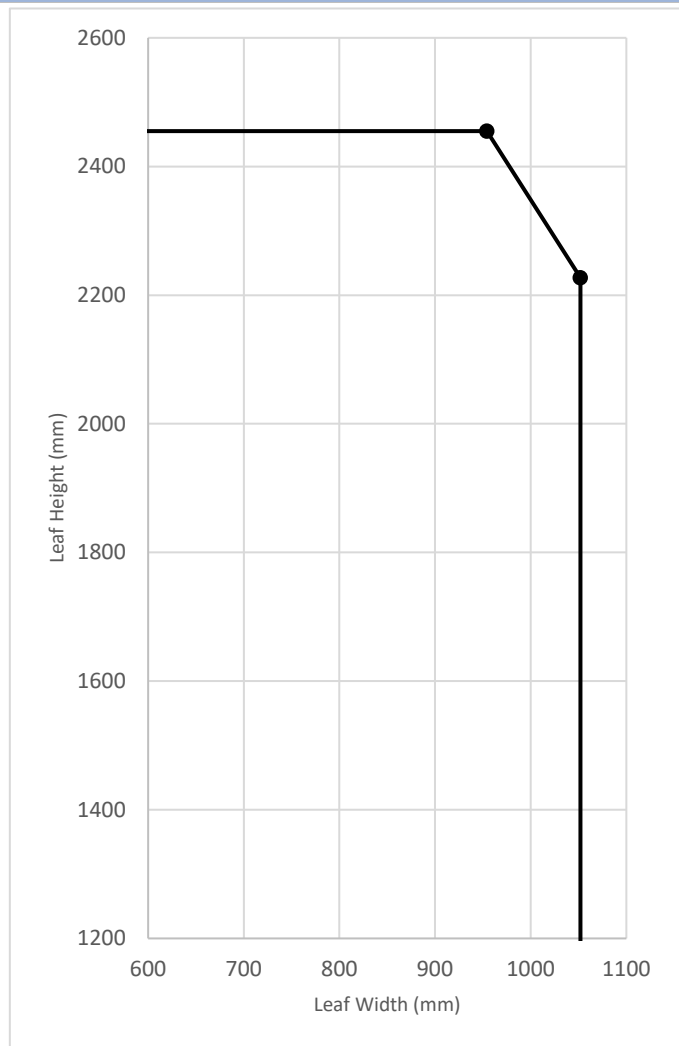

A.10 Approved Leaf Envelope A.10

REDUCED INTUMESCENT

FIGURE: A.10.1		LEAF CONFIGURATION: UNLATCHED, SINGLE ACTING, SINGLE DOOR, WITH SQUARE/REBATED OVERPANEL	
DOOR CONSTRUCTION OPTIONS			
44mm Halspan Optima			
FRAME MATERIAL			
Softwood or Hardwood			
LIPPING TYPES			
L30/1, L30/8			
MEETING STILE JUNCTION			
N/A			
OVERPANEL JUNCTION			
Square/ Equally Rebated / Unequally rebated			
LEAF ENVELOPE			
HEIGHT	WIDTH		
2072mm	966mm		
2142mm	934mm		
FIRE TEST EVIDENCE			
WARRES 131998 – Door B			
INTUMESCENT SPECIFICATION - STANDARD			
HEAD	FRAME	1no 10 x 4mm thick intumescent seal, positioned centrally to the leaf thickness	
VERTICAL EDGES	FRAME	1no 10 x 4mm thick intumescent seal, positioned centrally to the leaf thickness	
OVERPANEL JUNCTION	EQUALLY REBATED EDGE	1no 10 x 4mm thick intumescent seal in both leaves, located centrally in each rebate interface	
	UNEQUALLY REBATED EDGE	1no 10 x 4mm thick intumescent seal in both leaves, located centrally in each rebate interface	
	SQUARE BOTTOM EDGE	2no 10 x 4mm seals spaced 10mm apart and positioned centrally to the leaf thickness	
	OVERPANEL EDGES – TOP AND VERTICAL	1no 10 x 4mm thick intumescent seal, positioned centrally to the overpanel thickness	

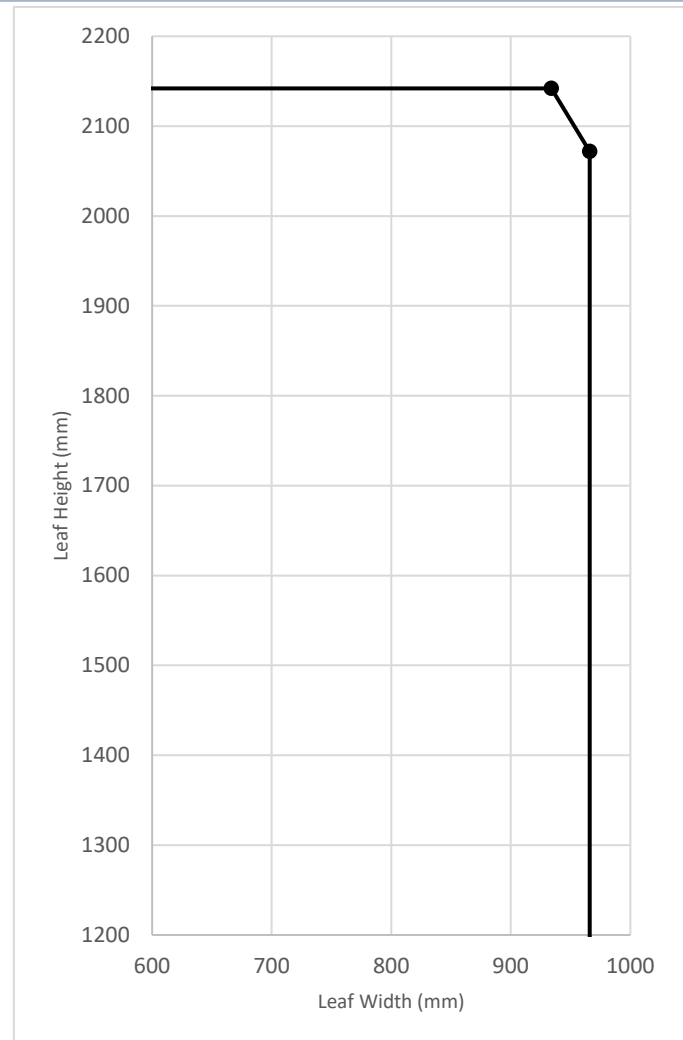

STANDARD INTUMESCENT SPEC

FIGURE:		LEAF CONFIGURATION:	
A.10.2		UNLATCHED, SINGLE ACTING, SINGLE DOOR, WITH SQUARE/REBATED OVERPANEL	
DOOR CONSTRUCTION OPTIONS			
44mm Halspan Optima			
FRAME MATERIAL			
Softwood or Hardwood			
LIPPING TYPES			
L30/1, L30/2			
MEETING STILE JUNCTION			
N/A			
OVERPANEL JUNCTION			
Square/ Equally Rebated / Unequally rebated			
LEAF ENVELOPE			
HEIGHT		WIDTH	
2072mm		966mm	
2142mm		934mm	
FIRE TEST EVIDENCE			
RF13063			
INTUMESCENT SPECIFICATION - STANDARD			
HEAD	FRAME	1no 15 x 4mm thick intumescent seal, positioned centrally to the leaf thickness	
VERTICAL EDGES	FRAME	1no 15 x 4mm thick intumescent seal, positioned centrally to the leaf thickness	
OVERPANEL JUNCTION	EQUALLY REBATED EDGE	2no 15 x 4mm thick intumescent seals, one positioned centrally to the rebate in the leaf and overpanel interface	
	UNEQUALLY REBATED EDGE	2no 15 x 4mm thick intumescent seals, one positioned centrally to the rebate in the leaf and overpanel interface	
	SQUARE BOTTOM EDGE	2no 15 x 4mm thick intumescent seals, one positioned in the leaf 7mm from the opening face of the leaf and the other in the bottom edge of the overpanel 7mm from the closing face of the assembly.	
	OVERPANEL EDGES – TOP AND VERTICAL	1no 15 x 4mm thick intumescent seal, positioned centrally to the overpanel thickness	

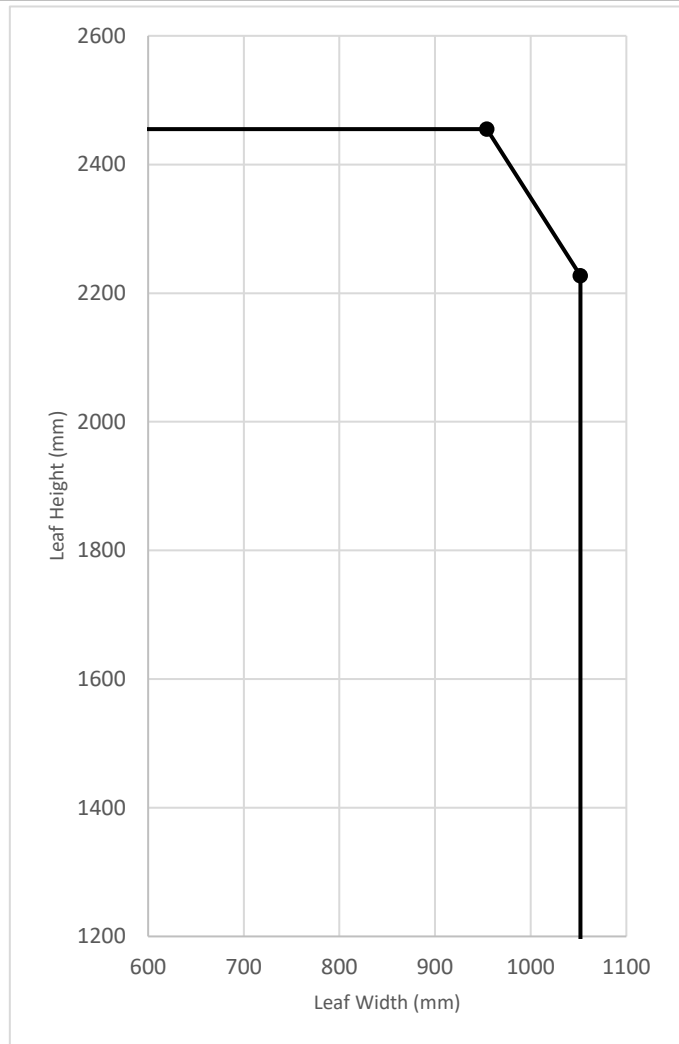

A.11 Approved Leaf Envelope A.11

REDUCED INTUMESCENT

FIGURE: A.11.1		LEAF CONFIGURATION: LATCHED, SINGLE ACTING, DOUBLE DOOR, WITH TRANSOMED OVERPANEL	
DOOR CONSTRUCTION OPTIONS			
44mm Halspan Optima			
FRAME MATERIAL			
Softwood or Hardwood			
LIPPING TYPES			
L30/1, L30/2			
MEETING STILE JUNCTION			
Square / Equally Rebated / Unequally Rebated			
OVERPANEL JUNCTION			
Transomed			
LEAF ENVELOPE			
HEIGHT	WIDTH		
2072mm	966mm		
2142mm	934mm		
FIRE TEST EVIDENCE			
WARRES 131998 – Door B			
INTUMESCENT SPECIFICATION			
HEAD	FRAME	1no 10 x 4mm thick intumescent seal, positioned centrally to the leaf thickness	
VERTICAL EDGES	FRAME	1no 10 x 4mm thick intumescent seal, positioned centrally to the leaf thickness	
MEETING STILES	SQUARE	2no 10 x 4mm seals spaced 10mm apart and positioned centrally to the leaf thickness	
	EQUALLY REBATED	1no 10 x 4mm thick intumescent seal in both leaves, located centrally in each rebate interface	
	UNEQUALLY REBATED	1no 10 x 4mm thick intumescent seal in both leaves, located centrally in each rebate interface	
TRANSOMED OVERPANEL	OVERPANEL EDGES	1no 10 x 4mm thick intumescent seal, positioned centrally to the overpanel thickness	

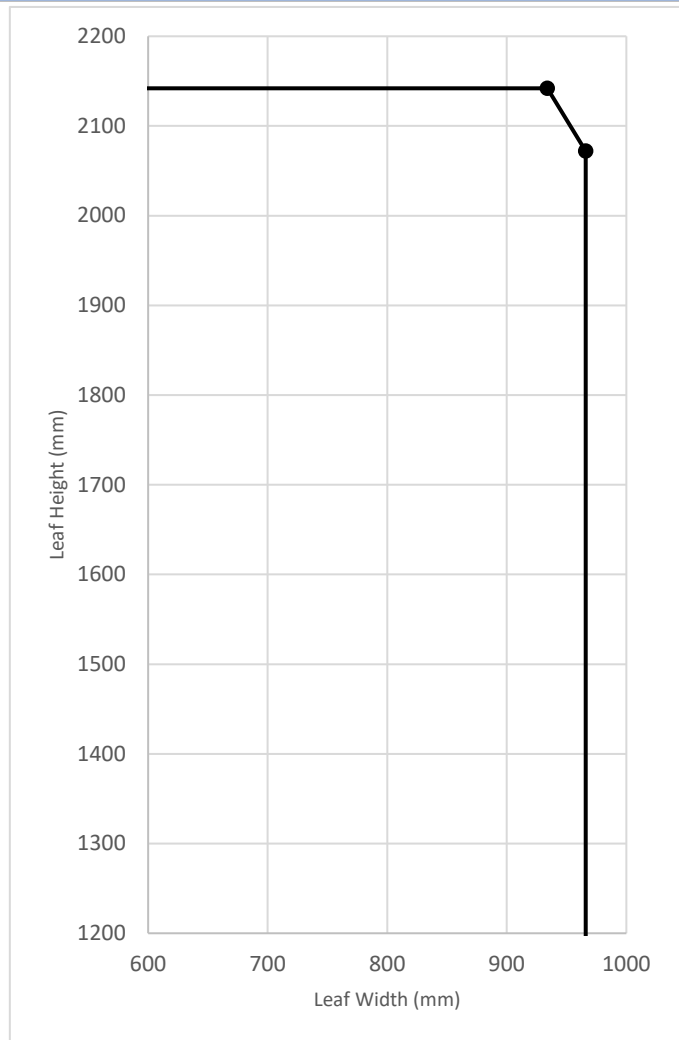

STANDARD INTUMESCENT

FIGURE: A.11.2		LEAF CONFIGURATION: LATCHED, SINGLE ACTING, DOUBLE DOOR, WITH TRANSOMED OVERPANEL	
DOOR CONSTRUCTION OPTIONS			
44mm Halspan Optima			
FRAME MATERIAL			
Softwood or Hardwood			
LIPPING TYPES			
L30/1			
MEETING STILE JUNCTION			
Square			
OVERPANEL JUNCTION			
Transomed			
LEAF ENVELOPE			
HEIGHT		WIDTH	
2227mm		1052mm	
2455mm		954mm	
FIRE TEST EVIDENCE			
RF13063			
INTUMESCENT SPECIFICATION			
HEAD	FRAME	1no 15 x 4mm thick intumescent seal, positioned centrally to the leaf thickness	
VERTICAL EDGES	FRAME	1no 15 x 4mm thick intumescent seal, positioned centrally to the leaf thickness	
MEETING STILES	SQUARE	1no 15 x 4mm thick intumescent seal, positioned centrally to the leaf thickness in one leaf	
TRANSOMED OVERPANEL	OVERPANEL EDGES	1no 15 x 4mm thick intumescent seal, positioned centrally to the overpanel thickness	

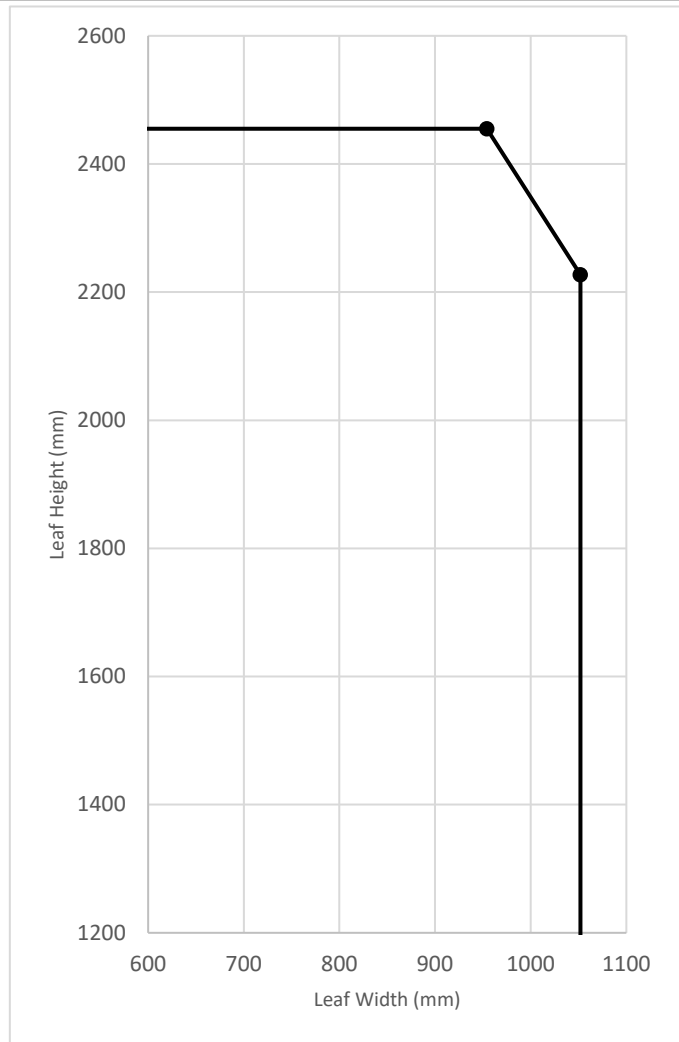

RADIUSED MEETING STILES

FIGURE: A.11.3		LEAF CONFIGURATION: LATCHED, SINGLE ACTING, DOUBLE DOOR, WITH TRANSOMED OVERPANEL	
DOOR CONSTRUCTION OPTIONS			
44mm Halspan Optima			
FRAME MATERIAL			
Softwood or Hardwood			
LIPPING TYPES			
L30/1, L30/3			
MEETING STILE JUNCTION			
Radiused			
OVERPANEL JUNCTION			
Transomed			
LEAF ENVELOPE			
HEIGHT		WIDTH	
2128mm		1059mm	
2346mm		961mm	
FIRE TEST EVIDENCE			
WARRES 135011			
INTUMESCENT SPECIFICATION			
HEAD	FRAME	1no 10 x 4mm thick intumescent seal, positioned centrally to the leaf thickness	
VERTICAL EDGES	FRAME	1no 10 x 4mm thick intumescent seal, positioned centrally to the leaf thickness	
MEETING STILES	RADIUSED	1no 10 x 4mm thick intumescent seal in each leaf, positioned centrally to the leaf thickness	
TRANSOMED OVERPANEL	OVERPANEL EDGES	1no 10 x 4mm thick intumescent seal, positioned centrally to the overpanel thickness	

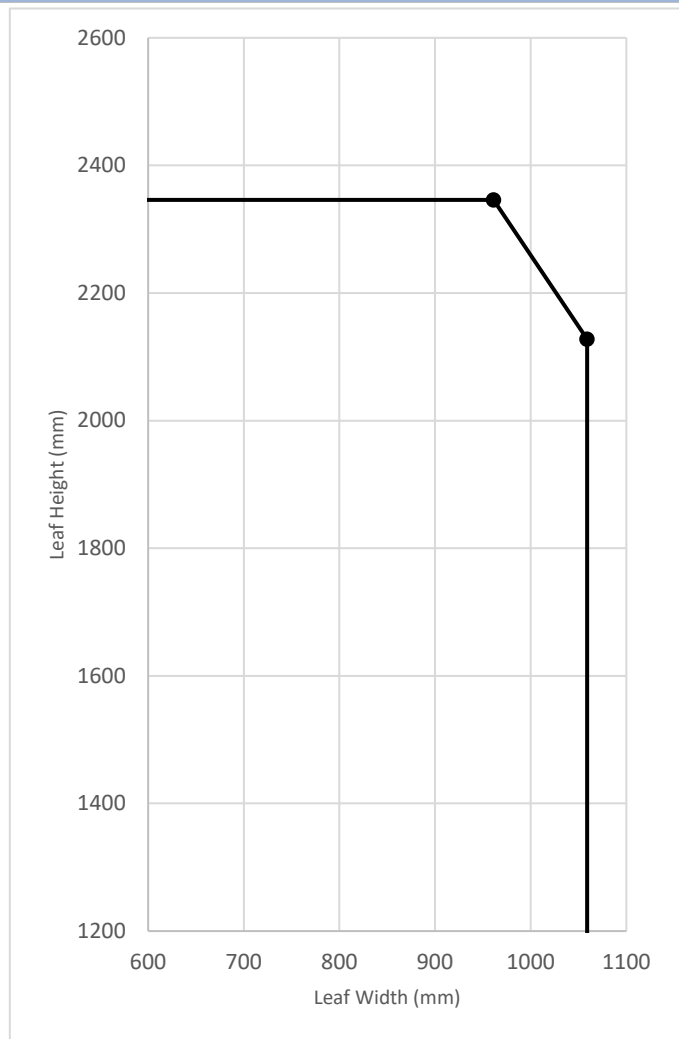

A.12 Approved Leaf Envelope A.12

REDUCED INTUMESCENT

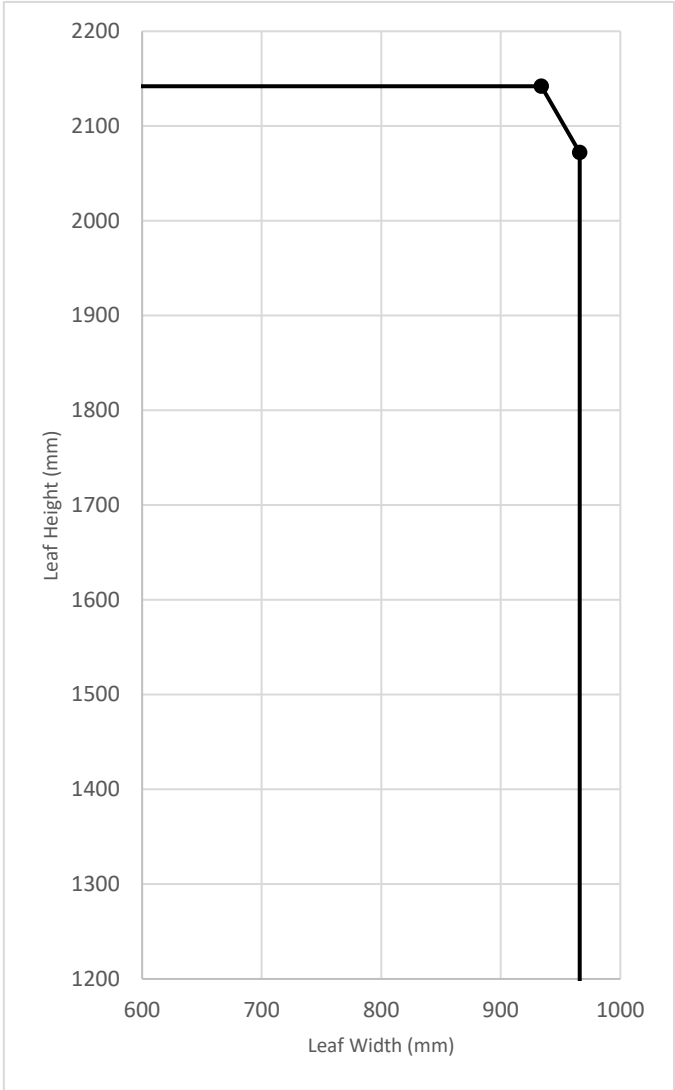
FIGURE: A.12.1		LEAF CONFIGURATION: LATCHED, SINGLE ACTING, DOUBLE DOOR, WITH SQUARE/REBATED OVERPANEL	
DOOR CONSTRUCTION OPTIONS			
44mm Halspan Optima			
FRAME MATERIAL			
Softwood or Hardwood			
LIPPING TYPES			
L30/1, L30/2			
MEETING STILE JUNCTION			
Square / Equally rebated / Unequally Rebated			
OVERPANEL JUNCTION			
Square / Equally Rebated / Unequally rebated			
LEAF ENVELOPE			
HEIGHT	WIDTH		
2072mm	966mm		
2142mm	934mm		
FIRE TEST EVIDENCE			
WARRES131998 – Door B			
			
INTUMESCENT SPECIFICATION			
HEAD	FRAME	1no 10 x 4mm thick intumescent seal, positioned centrally to the leaf thickness	
VERTICAL EDGES	FRAME	1no 10 x 4mm thick intumescent seal, positioned centrally to the leaf thickness	
MEETING STILES	SQUARE	2no 10 x 4mm seals spaced 10mm apart and positioned centrally to the leaf thickness	
	EQUALLY REBATED	1no 10 x 4mm thick intumescent seal in both leaves, located centrally in each rebate interface	
	UNEQUALLY REBATED	1no 10 x 4mm thick intumescent seal in both leaves, located centrally in each rebate interface	

INTUMESCENT SPECIFICATION		
OVERPANEL JUNCTION	EQUALLY REBATED EDGE	1no 10 x 4mm thick intumescent seal in both leaves, located centrally in each rebate interface
	UNEQUALLY REBATED EDGE	1no 10 x 4mm thick intumescent seal in both leaves, located centrally in each rebate interface
	SQUARE BOTTOM EDGE	2no 10 x 4mm seals spaced 10mm apart and positioned centrally to the leaf thickness
	OVERPANEL EDGES – TOP AND VERTICAL	1no 10 x 4mm thick intumescent seal, positioned centrally to the overpanel thickness

STANDARD INTUMESCENT

FIGURE: A.12.2		LEAF CONFIGURATION: LATCHED, SINGLE ACTING, DOUBLE DOOR, WITH SQUARE/REBATED OVERPANEL	
DOOR CONSTRUCTION OPTIONS			
44mm Halspan Optima			
FRAME MATERIAL			
Softwood or Hardwood			
LIPPING TYPES			
L30/1, L30/2			
MEETING STILE JUNCTION			
Square			
OVERPANEL JUNCTION			
Square / Equally Rebated / Unequally rebated			
LEAF ENVELOPE			
HEIGHT		WIDTH	
2227mm		1052mm	
2455mm		954mm	
FIRE TEST EVIDENCE			
RF13063			
INTUMESCENT SPECIFICATION			
HEAD	FRAME	1no 15 x 4mm thick intumescent seal, positioned centrally to the leaf thickness	
VERTICAL EDGES	FRAME	1no 15 x 4mm thick intumescent seal, positioned centrally to the leaf thickness	
MEETING STILES	SQUARE	1no 15 x 4mm thick intumescent seal, positioned centrally to the leaf thickness in one leaf	

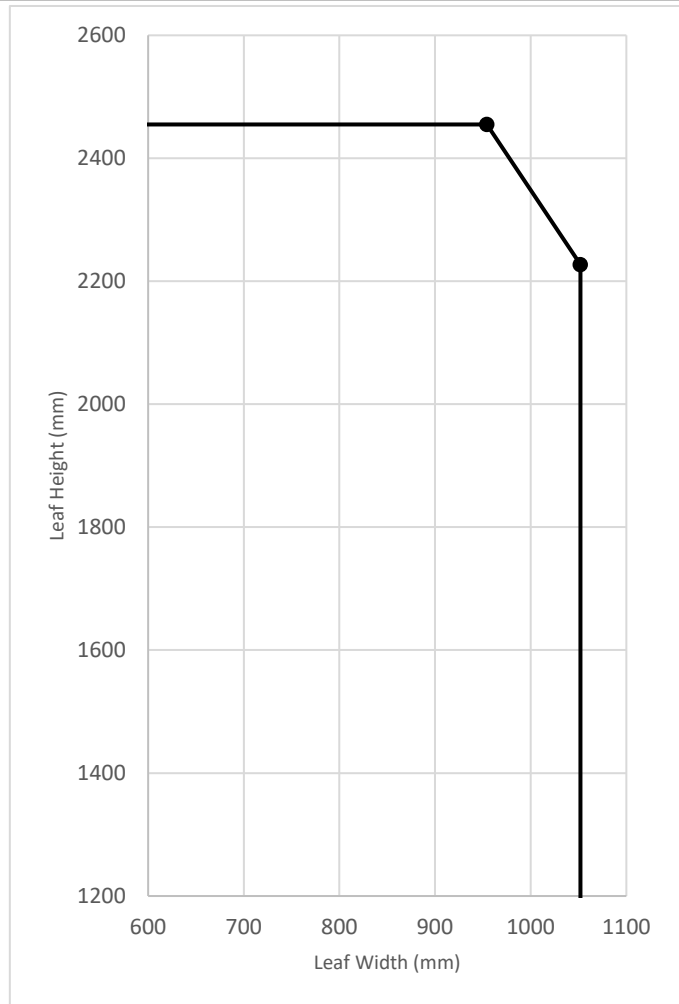

INTUMESCENT SPECIFICATION		
OVERPANEL JUNCTION	EQUALLY REBATED EDGE	2no 15 x 4mm thick intumescent seals, one positioned centrally to the rebate in the leaf and overpanel
	UNEQUALLY REBATED EDGE	2no 15 x 4mm thick intumescent seals, one positioned centrally to the rebate in the leaf and overpanel
	SQUARE BOTTOM EDGE	2no 15 x 4mm thick intumescent seals, one positioned in the leaf 7mm from the opening face of the leaf and the other in the bottom edge of the overpanel 7mm from the closing face of the assembly.
	OVERPANEL EDGES – TOP AND VERTICAL	1no 15 x 4mm thick intumescent seal, positioned centrally to the overpanel thickness

RADIUS MEETING STILES

FIGURE:	LEAF CONFIGURATION:
A.12.3	LATCHED, SINGLE ACTING, DOUBLE DOOR, WITH SQUARE OVERPANEL

DOOR CONSTRUCTION OPTIONS	
44mm Halspan Optima	
FRAME MATERIAL	
Softwood or Hardwood	
LIPPING TYPES	
L30/1, L30/2, L30/3	
MEETING STILE JUNCTION	
Radiused	
OVERPANEL JUNCTION	
Square	
LEAF ENVELOPE	
HEIGHT	WIDTH
2128mm	1059mm
2346mm	961mm
FIRE TEST EVIDENCE	
WARRES 135011	

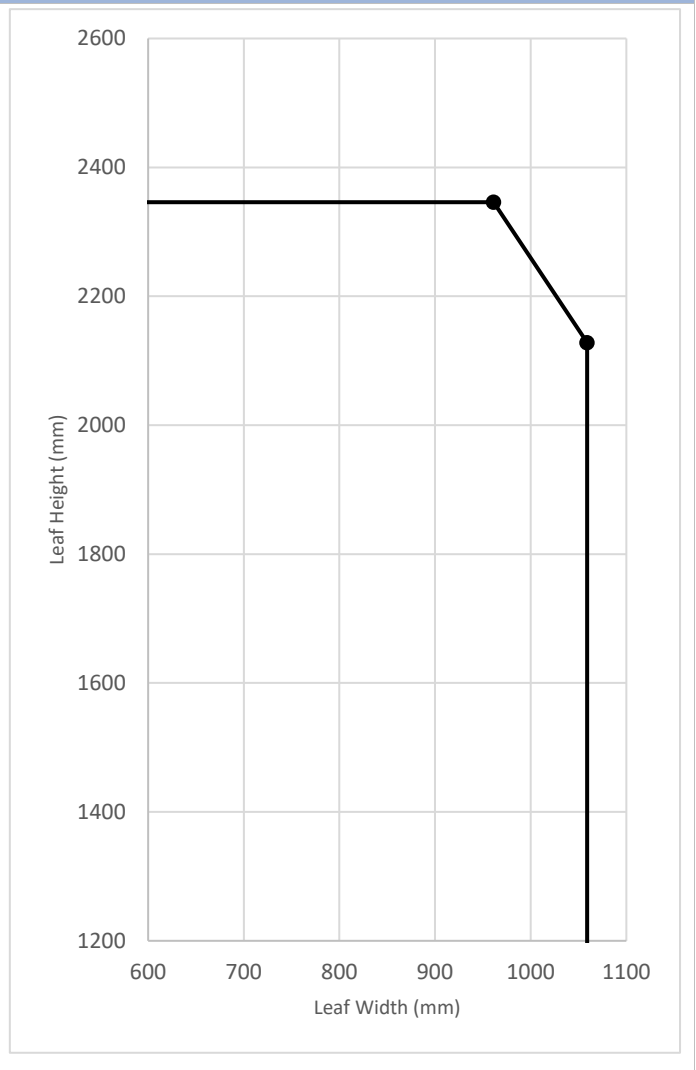

INTUMESCENT SPECIFICATION

HEAD	FRAME	1no 10 x 4mm thick intumescent seal, positioned centrally to the leaf thickness
VERTICAL EDGES	FRAME	1no 10 x 4mm thick intumescent seal, positioned centrally to the leaf thickness
MEETING STILES	RADIUSED	1no 10 x 4mm thick intumescent seal in each leaf, positioned centrally to the leaf thickness
OVERPANEL JUNCTION	SQUARE BOTTOM EDGE	1no 15 x 4mm thick intumescent seal, positioned centrally to the overpanel thickness
	OVERPANEL EDGES – TOP AND VERTICAL	1no 10 x 4mm thick intumescent seal, positioned centrally to the overpanel thickness

A.13 Approved Leaf Envelope A.13

REDUCED INTUMESCENT

FIGURE: A.13.1		LEAF CONFIGURATION: UNLATCHED, SINGLE ACTING, DOUBLE DOOR, WITH TRANSOMED OVERPANEL	
DOOR CONSTRUCTION OPTIONS			
44mm Halspan Optima			
FRAME MATERIAL			
Softwood or Hardwood			
LIPPING TYPES			
L30/1, L30/2			
MEETING STILE JUNCTION			
Square / Equally Rebated / Unequally Rebated			
OVERPANEL JUNCTION			
Transomed			
LEAF ENVELOPE			
HEIGHT	WIDTH		
2072mm	966mm		
2142mm	934mm		
FIRE TEST EVIDENCE			
WARRES 131998 – Door B			
INTUMESCENT SPECIFICATION			
HEAD	FRAME	1no 10 x 4mm thick intumescent seal, positioned centrally to the leaf thickness	
VERTICAL EDGES	FRAME	1no 10 x 4mm thick intumescent seal, positioned centrally to the leaf thickness	
MEETING STILES	SQUARE	2no 10 x 4mm seals spaced 10mm apart and positioned centrally to the leaf thickness	
	EQUALLY REBATED	1no 10 x 4mm thick intumescent seal in both leaves, located centrally in each rebate	
	UNEQUALLY REBATED	1no 10 x 4mm thick intumescent seal in both leaves, located centrally in each rebate	
TRANSOMED OVERPANEL	OVERPANEL EDGES	1no 10 x 4mm thick intumescent seal, positioned centrally to the overpanel thickness	

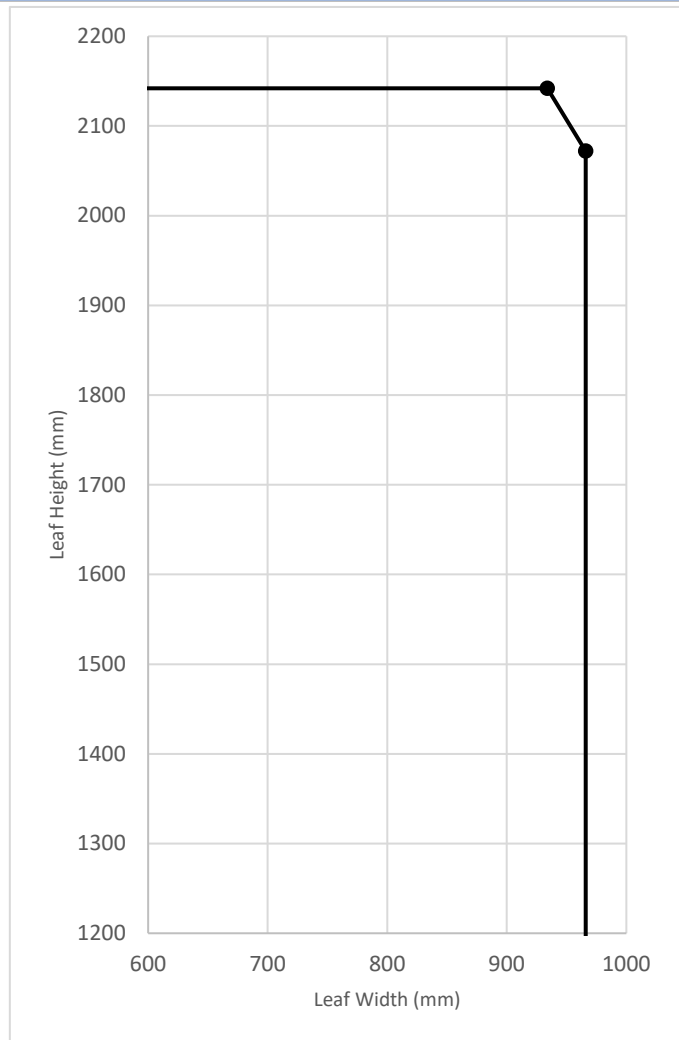

STANDARD INTUMESCENT

FIGURE: A.13.2		LEAF CONFIGURATION: UNLATCHED, SINGLE ACTING, DOUBLE DOOR, WITH TRANSOMED OVERPANEL	
DOOR CONSTRUCTION OPTIONS			
44mm Halspan Optima			
FRAME MATERIAL			
Softwood or Hardwood			
LIPPING TYPES			
L30/1			
MEETING STILE JUNCTION			
Square			
OVERPANEL JUNCTION			
Transomed			
LEAF ENVELOPE			
HEIGHT		WIDTH	
2227mm		1052mm	
2455mm		954mm	
FIRE TEST EVIDENCE			
RF13063			
INTUMESCENT SPECIFICATION			
HEAD	FRAME	1no 15 x 4mm thick intumescent seal, positioned centrally to the leaf thickness	
VERTICAL EDGES	FRAME	1no 15 x 4mm thick intumescent seal, positioned centrally to the leaf thickness	
MEETING STILES	SQUARE	1no 15 x 4mm thick intumescent seal, positioned centrally to the leaf thickness	
TRANSOMED OVERPANEL	OVERPANEL EDGES	1no 15 x 4mm thick intumescent seal, positioned centrally to the overpanel thickness	

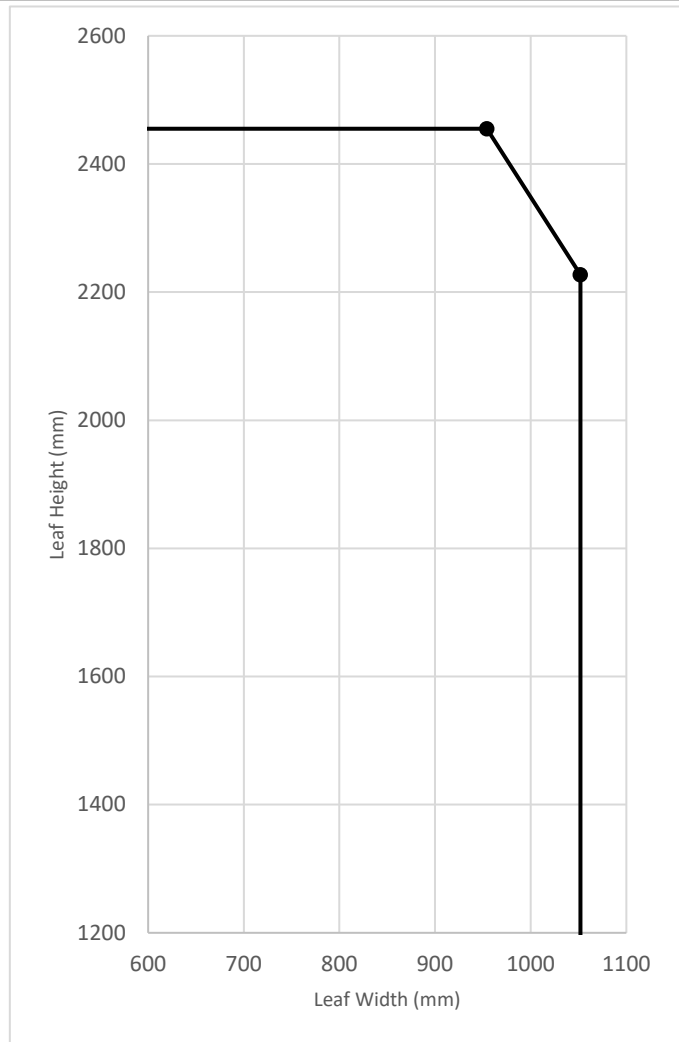

RADIUSED MEETING STILES

FIGURE: A.13.3		LEAF CONFIGURATION: UNLATCHED, SINGLE ACTING, DOUBLE DOOR, WITH TRANSOMED OVERPANEL	
DOOR CONSTRUCTION OPTIONS			
44mm Halspan Optima			
FRAME MATERIAL			
Softwood or Hardwood			
LIPPING TYPES			
L30/1, L30/3			
MEETING STILE JUNCTION			
Radiused			
OVERPANEL JUNCTION			
Transomed			
LEAF ENVELOPE			
HEIGHT		WIDTH	
2128mm		1059mm	
2346mm		961mm	
FIRE TEST EVIDENCE			
WARRES 135011			
INTUMESCENT SPECIFICATION			
HEAD	FRAME	1no 10 x 4mm thick intumescent seal, positioned centrally to the leaf thickness	
VERTICAL EDGES	FRAME	1no 10 x 4mm thick intumescent seal, positioned centrally to the leaf thickness	
MEETING STILES	RADIUSED	1no 10 x 4mm thick intumescent seal in each leaf, positioned centrally to the leaf thickness	
TRANSOMED OVERPANEL	OVERPANEL EDGES	1no 10 x 4mm thick intumescent seal, positioned centrally to the overpanel thickness	

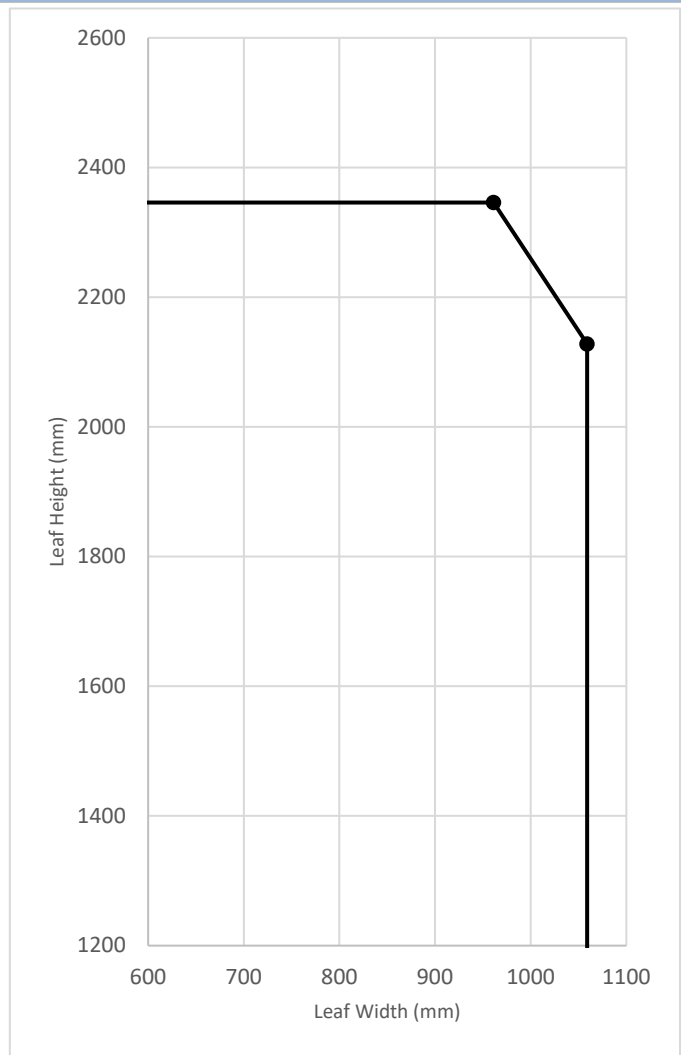

A.14 Approved Leaf Envelope A.14

REDUCED INTUMESCENT

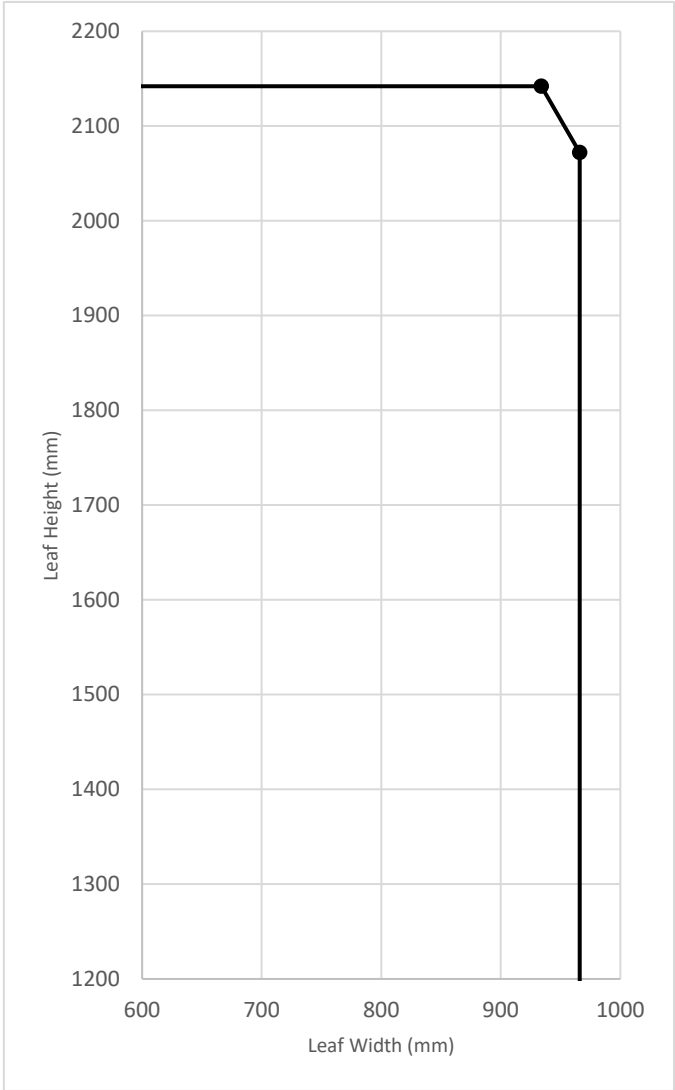
FIGURE: A.14.1		LEAF CONFIGURATION: UNLATCHED, SINGLE ACTING, DOUBLE DOOR, WITH SQUARE/REBATED OVERPANEL	
DOOR CONSTRUCTION OPTIONS			
44mm Halspan Optima			
FRAME MATERIAL			
Softwood or Hardwood			
LIPPING TYPES			
L30/1, L30/2			
MEETING STILE JUNCTION			
Square / Equally rebated / Unequally Rebated			
OVERPANEL JUNCTION			
Square / Equally Rebated / Unequally rebated			
LEAF ENVELOPE			
HEIGHT	WIDTH		
2072mm	966mm		
2142mm	934mm		
FIRE TEST EVIDENCE			
WARRES 131998 – Door B			
			
INTUMESCENT SPECIFICATION			
HEAD	FRAME	1no 10 x 4mm thick intumescent seal, positioned centrally to the leaf thickness	
VERTICAL EDGES	FRAME	1no 10 x 4mm thick intumescent seal, positioned centrally to the leaf thickness	
MEETING STILES	SQUARE	2no 10 x 4mm seals spaced 10mm apart, positioned centrally to the leaf thickness	
	EQUALLY REBATED	1n 10 x 4mm thick intumescent seal fitted centrally to each rebate interface	
	UNEQUALLY REBATED	1n 10 x 4mm thick intumescent seal fitted centrally to each rebate interface	

INTUMESCENT SPECIFICATION		
OVERPANEL JUNCTION	EQUALLY REBATED EDGE	1n 10 x 4mm thick intumescent seal fitted centrally to each rebate interface
	UNEQUALLY REBATED EDGE	1n 10 x 4mm thick intumescent seal fitted centrally to each rebate interface
	SQUARE BOTTOM EDGE	2no 10 x 4mm seals spaced 10mm apart, positioned centrally to the leaf thickness
	OVERPANEL EDGES – TOP AND VERTICAL	1no 10 x 4mm thick intumescent seal, positioned centrally to the overpanel thickness

STANDARD INTUMESCENT

FIGURE: A.14.2	LEAF CONFIGURATION: UNLATCHED, SINGLE ACTING, DOUBLE DOOR, WITH SQUARE/REBATED OVERPANEL
-------------------	---

DOOR CONSTRUCTION OPTIONS	
44mm Halspan Optima	
FRAME MATERIAL	
Softwood or Hardwood	
LIPPING TYPES	
L30/1, L30/2	
MEETING STILE JUNCTION	
Square	
OVERPANEL JUNCTION	
Square / Equally Rebated / Unequally rebated	
LEAF ENVELOPE	
HEIGHT	WIDTH
2227mm	1052mm
2455mm	954mm
FIRE TEST EVIDENCE	
RF13063	

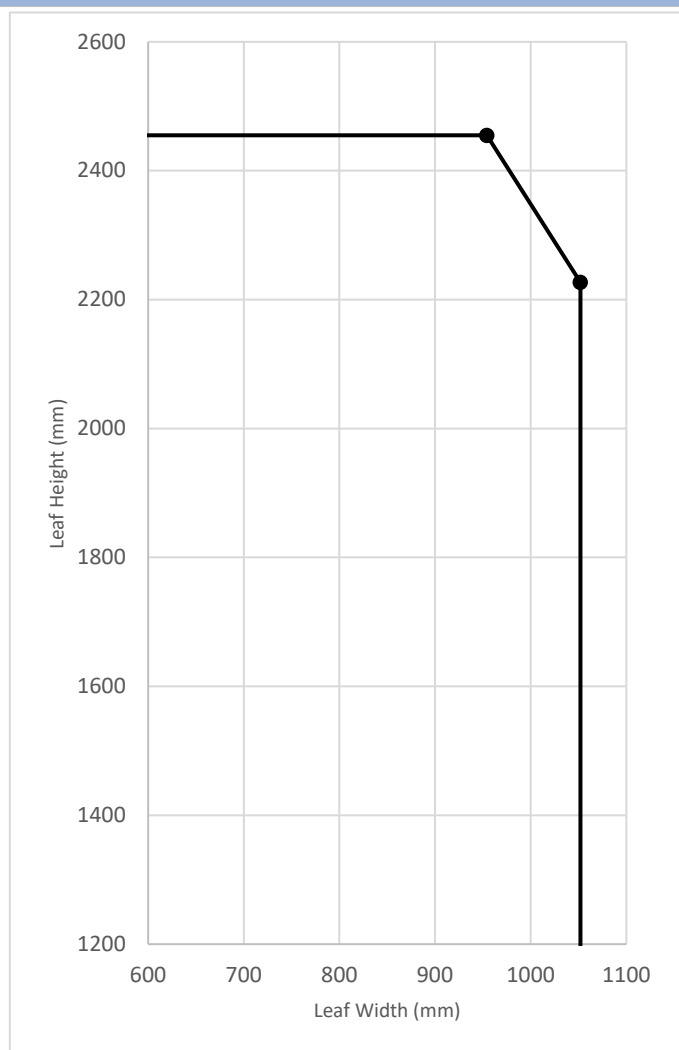

INTUMESCENT SPECIFICATION

HEAD	FRAME	1no 15 x 4mm thick intumescent seal, positioned centrally to the leaf thickness
VERTICAL EDGES	FRAME	1no 15 x 4mm thick intumescent seal, positioned centrally to the leaf thickness
MEETING STILES	SQUARE	1no 15 x 4mm thick intumescent seal in one leaf edge leaf, positioned centrally to the leaf thickness
OVERPANEL JUNCTION	EQUALLY REBATED EDGE	1no 15mm x 4mm thick intumescent seal fitted centrally to each rebate in the leaf and overpanel interface
	UNEQUALLY REBATED EDGE	1no 15mm x 4mm thick intumescent seal fitted centrally to each rebate in the leaf and overpanel interface
	SQUARE BOTTOM EDGE	2no 15mm x 4mm seals fitted in both the bottom edge of the overpanel, spaced 7mm apart
	OVERPANEL EDGES – TOP AND VERTICAL	1no 15 x 4mm thick intumescent seal, positioned centrally to the overpanel thickness

REDUCED INTUMESCENT, RADIUS MEETING STILES

FIGURE: A.14.3		LEAF CONFIGURATION: UNLATCHED, SINGLE ACTING, DOUBLE DOOR, WITH SQUARE OVERPANEL	
DOOR CONSTRUCTION OPTIONS			
44mm Halspan Optima			
FRAME MATERIAL			
Softwood or Hardwood			
LIPPING TYPES			
L30/1, L30/2, L30/3			
MEETING STILE JUNCTION			
Radiused			
OVERPANEL JUNCTION			
Square			
LEAF ENVELOPE			
HEIGHT		WIDTH	
2128mm		1059mm	
2346mm		961mm	
FIRE TEST EVIDENCE			
WARRES 135011			
INTUMESCENT SPECIFICATION			
HEAD	FRAME	1no 10 x 4mm thick intumescent seal, positioned centrally to the leaf thickness	
VERTICAL EDGES	FRAME	1no 10 x 4mm thick intumescent seal, positioned centrally to the leaf thickness	
MEETING STILES	SQUARE OR RADIUSED	1no 10 x 4mm thick intumescent seal in each leaf, positioned centrally to the leaf thickness	
OVERPANEL	SQUARE BOTTOM EDGE	1no 15 x 4mm thick intumescent seal, positioned centrally to the overpanel thickness	
	OVERPANEL EDGES – TOP AND VERTICAL	1no 10 x 4mm thick intumescent seal, positioned centrally to the overpanel thickness	

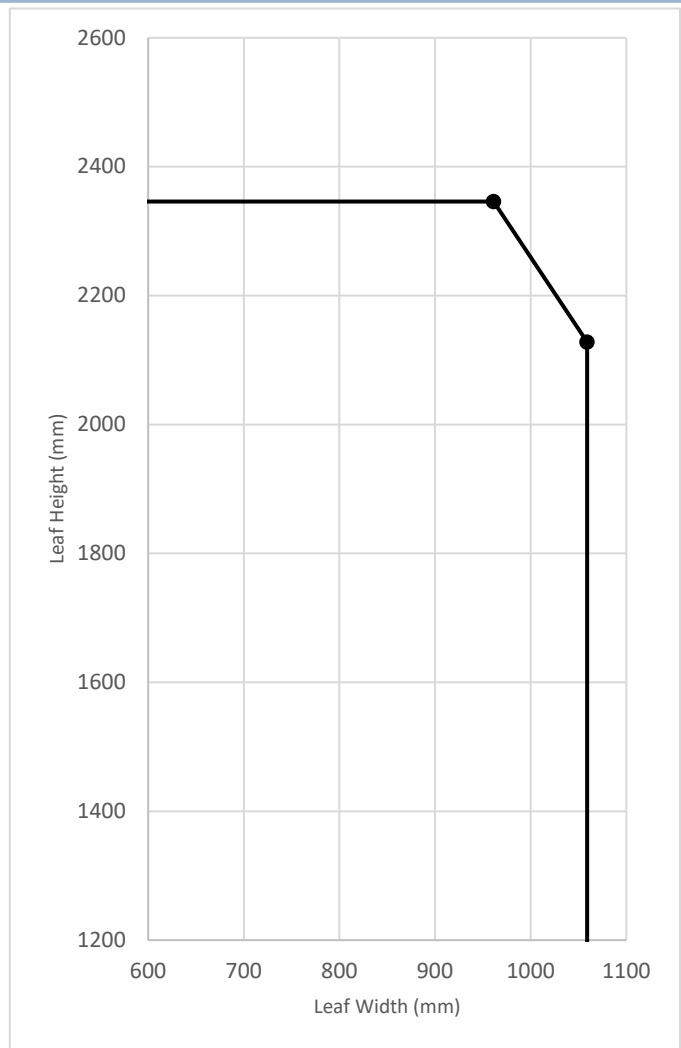

A.15 Approved Leaf Envelope A.15

FIGURE:		LEAF CONFIGURATION:	
A.15		DOUBLE ACTING, DOUBLE DOOR, WITH SQUARE OVERPANEL	
DOOR CONSTRUCTION OPTIONS			
44mm Halspan Optima			
FRAME MATERIAL			
Softwood or Hardwood			
LIPPING TYPES			
L30/1, L30/3			
MEETING STILE JUNCTION			
Square or Radiused			
OVERPANEL JUNCTION			
Square			
LEAF ENVELOPE			
HEIGHT		WIDTH	
2128mm		1059mm	
2346mm		961mm	
FIRE TEST EVIDENCE			
WARRES 135011			
INTUMESCENT SPECIFICATION			
HEAD	FRAME	1no 10 x 4mm thick intumescent seal, positioned centrally to the leaf thickness	
VERTICAL EDGES	FRAME	1no 10 x 4mm thick intumescent seal, positioned centrally to the leaf thickness	
MEETING STILES	SQUARE OR RADIUSED	1no 10 x 4mm thick intumescent seal in each leaf, positioned centrally to the leaf thickness	
OVERPANEL	SQUARE BOTTOM EDGE	1no 15 x 4mm thick intumescent seal, positioned centrally to the overpanel thickness	
	OVERPANEL EDGES – TOP AND VERTICAL	1no 10 x 4mm thick intumescent seal, positioned centrally to the overpanel thickness	

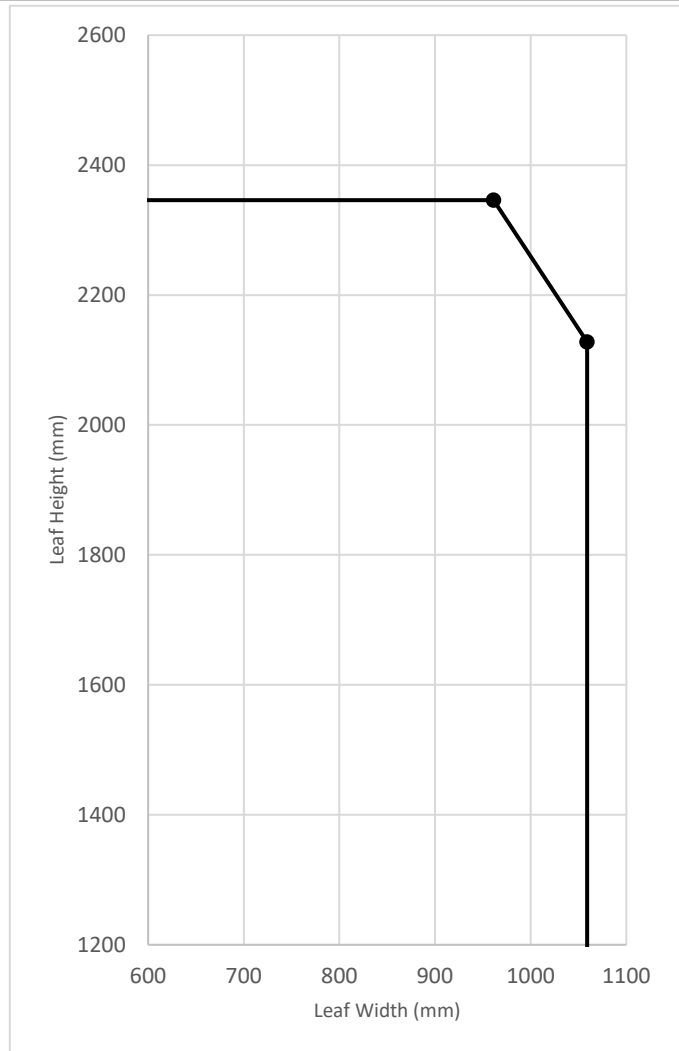

A.16 Approved Leaf Envelope A.16

FIGURE:		LEAF CONFIGURATION:	
A.16		DOUBLE ACTING, DOUBLE DOOR, WITH TRANSOMED OVERPANEL	
DOOR CONSTRUCTION OPTIONS			
44mm Halspan Optima			
FRAME MATERIAL			
Softwood or Hardwood			
LIPPING TYPES			
L30/1, L30/3			
MEETING STILE JUNCTION			
Square or Radiused			
OVERPANEL JUNCTION			
Transomed			
LEAF ENVELOPE			
HEIGHT	WIDTH		
2128mm	1059mm		
2346mm	961mm		
FIRE TEST EVIDENCE			
WARRES 135011			
INTUMESCENT SPECIFICATION			
HEAD	FRAME	1no 10 x 4mm thick intumescent seal, positioned centrally to the leaf thickness	
VERTICAL EDGES	FRAME	1no 10 x 4mm thick intumescent seal, positioned centrally to the leaf thickness	
MEETING STILES	SQUARE OR RADIUSED	1no 10 x 4mm thick intumescent seal in each leaf, positioned centrally to the leaf thickness	
TRANSOMED OVERPANEL	OVERPANEL EDGES	1no 10 x 4mm thick intumescent seal, positioned centrally to the overpanel thickness	

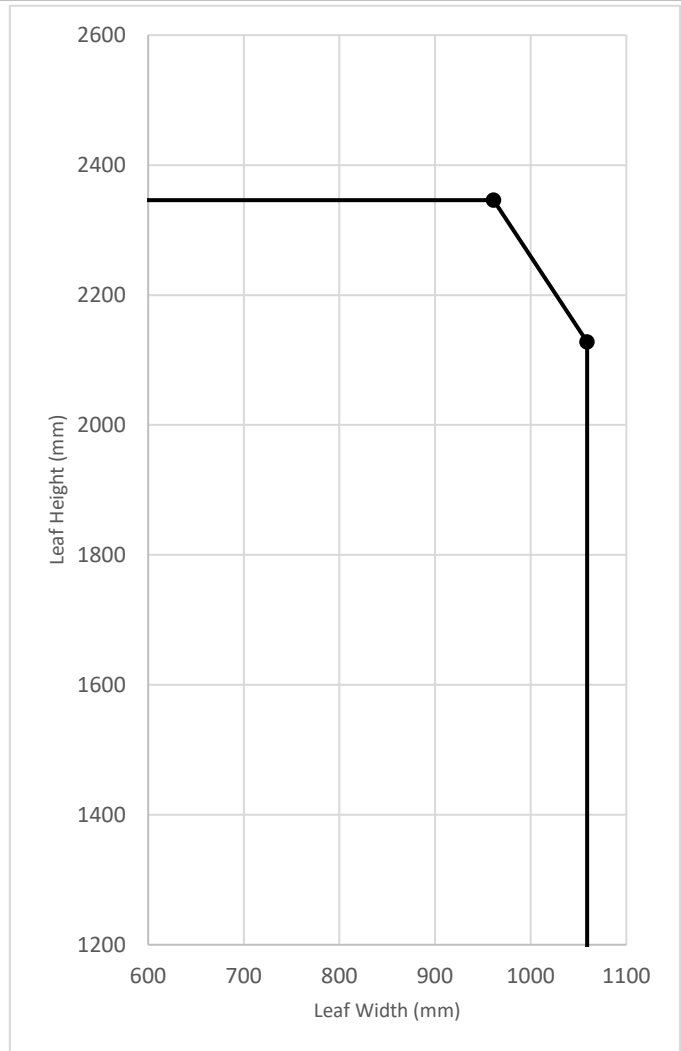

Appendix B – Approved Leaf Envelopes and Intumescent Seal Specifications for 44mm Thick Optima FD30 Doors in MDF Frames

CONFIGURATION DESCRIPTION	CONFIGURATION CODE
Latched, Single Acting, Single Leaf / Optional transomed overpanel only	LSASD
Unlatched, Single Acting, Single Leaf / Optional transomed overpanel only	ULSASD
Double Acting, Single Leaf / Optional transomed overpanel only	DASD
Latched, Single Acting, Single Leaf with Flush Overpanel	LSASD+OP
Unlatched, Single Acting, Single Leaf with Flush Overpanel	ULSASD+OP
Double Acting, Single Leaf with Flush Overpanel	DASD+OP
Latched, Single Acting, Double Leaf / Optional transomed overpanel only	LSADD
Unlatched, Single Acting, Double Leaf / Optional transomed overpanel only	ULSADD
Double Acting, Double Leaf / Optional transomed overpanel only	DADD
Latched, Single Acting, Double Leaf with Flush Overpanel	LSADD+OP
Unlatched, Single Acting, Double Leaf with Flush Overpanel	ULSADD+OP
Double Acting, Double Leaf with Flush Overpanel	DADD+OP

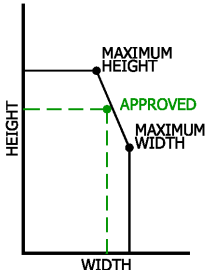
B.1 Approved Leaf Envelope B.01

FIGURE:		LEAF CONFIGURATION:	
B.01		LATCHED, SINGLE ACTING, SINGLE DOOR	
DOOR CONSTRUCTION OPTIONS			
44mm Halspan Optima			
FRAME MATERIAL			
MDF			
LIPPING TYPES			
L30/1, L30/8			
MEETING STILE JUNCTION			
N/A			
OVERPANEL JUNCTION			
N/A			
LEAF ENVELOPE			
HEIGHT	WIDTH		
2128mm	948mm		
2346mm	860mm		
FIRE TEST EVIDENCE			
RF01059			
INTUMESCENT SPECIFICATION			
HEAD	FRAME	1no 10 x 4mm thick intumescent seal, positioned centrally to the leaf thickness	
VERTICAL EDGES	FRAME	1no 10 x 4mm thick intumescent seal, positioned centrally to the leaf thickness	

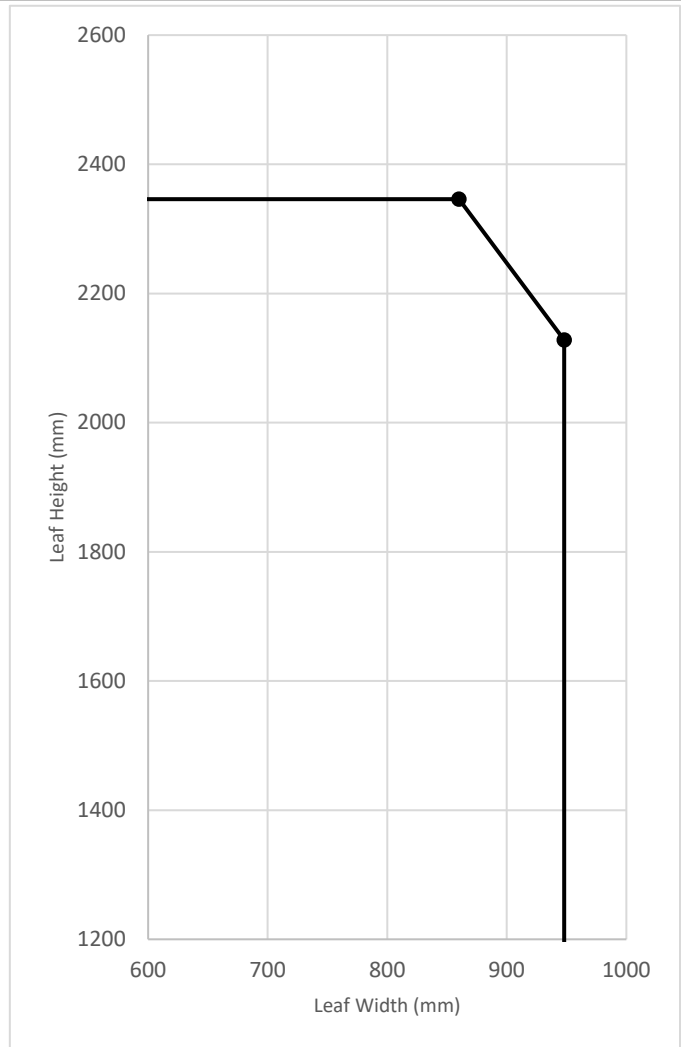

B.2 Approved Leaf Envelope C.02

FIGURE:		LEAF CONFIGURATION:	
B.02		UNLATCHED, SINGLE ACTING, SINGLE DOOR	
DOOR CONSTRUCTION OPTIONS			
44mm Halspan Optima			
FRAME MATERIAL			
MDF			
LIPPING TYPES			
L30/1, L30/8			
MEETING STILE JUNCTION			
N/A			
OVERPANEL JUNCTION			
N/A			
LEAF ENVELOPE			
HEIGHT		WIDTH	
2128mm		948mm	
2346mm		860mm	
FIRE TEST EVIDENCE			
RF01059			
INTUMESCENT SPECIFICATION			
HEAD	FRAME	1no 10 x 4mm thick intumescent seal, positioned centrally to the leaf thickness	
VERTICAL EDGES	FRAME	1no 10 x 4mm thick intumescent seal, positioned centrally to the leaf thickness	

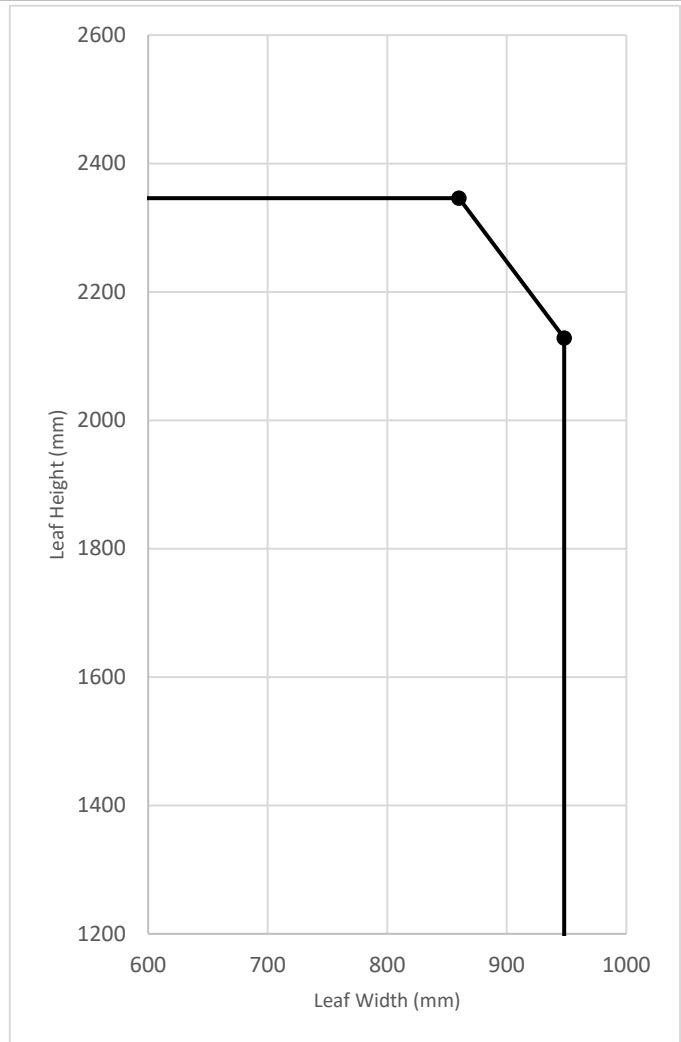

Appendix C – Approved Leaf Envelopes and Intumescent Seal Specifications for 44mm Thick Optima FD30 Doors in STEEL Frames

CONFIGURATION DESCRIPTION	CONFIGURATION CODE
Latched, Single Acting, Single Leaf / Optional transomed overpanel only	LSASD
Unlatched, Single Acting, Single Leaf / Optional transomed overpanel only	ULSASD
Double Acting, Single Leaf / Optional transomed overpanel only	DASD
Latched, Single Acting, Single Leaf with Flush Overpanel	LSASD+OP
Unlatched, Single Acting, Single Leaf with Flush Overpanel	ULSASD+OP
Double Acting, Single Leaf with Flush Overpanel	DASD+OP
Latched, Single Acting, Double Leaf / Optional transomed overpanel only	LSADD
Unlatched, Single Acting, Double Leaf / Optional transomed overpanel only	ULSADD
Double Acting, Double Leaf / Optional transomed overpanel only	DADD
Latched, Single Acting, Double Leaf with Flush Overpanel	LSADD+OP
Unlatched, Single Acting, Double Leaf with Flush Overpanel	ULSADD+OP
Double Acting, Double Leaf with Flush Overpanel	DADD+OP

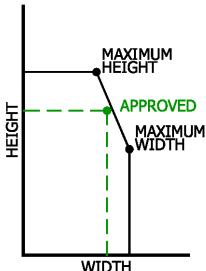
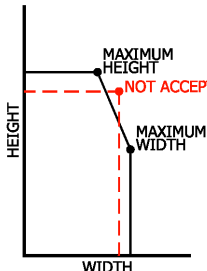
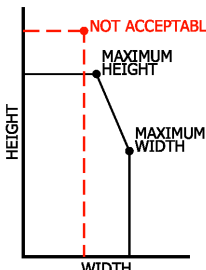
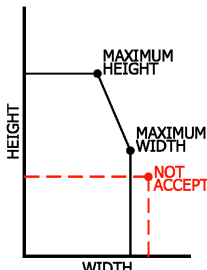
C.1 Approved Leaf Envelope C.01

FIGURE: C.01		LEAF CONFIGURATION: LATCHED, SINGLE ACTING, SINGLE DOOR	
DOOR CONSTRUCTION OPTIONS			
44mm Halspan Optima			
FRAME MATERIAL			
Steel			
LIPPING TYPES			
L30/1			
MEETING STILE JUNCTION			
N/A			
OVERPANEL JUNCTION			
N/A			
LEAF ENVELOPE			
HEIGHT		WIDTH	
2227mm		1270mm	
2455mm		1153mm	
FIRE TEST EVIDENCE			
RF01074			
INTUMESCENT SPECIFICATION			
HEAD	LEAF	1no 20 x 4mm thick intumescent seal, positioned centrally to the leaf thickness	
VERTICAL EDGES	LEAF	1no 20 x 4mm thick intumescent seal, positioned centrally to the leaf thickness	

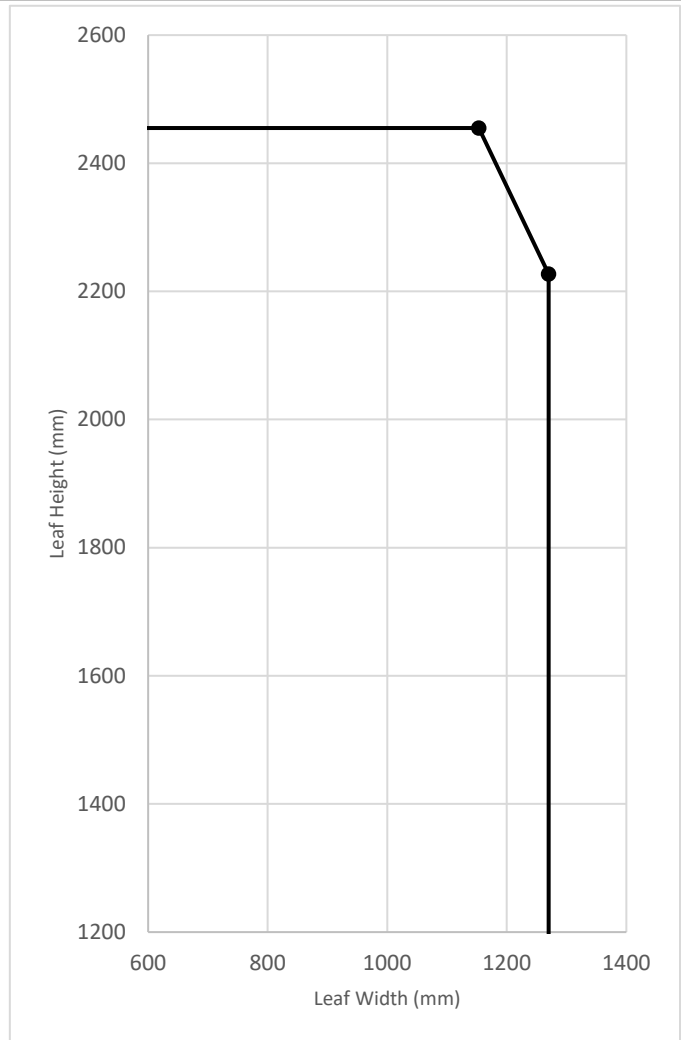

C.2 Approved Leaf Envelope C.02

FIGURE:		LEAF CONFIGURATION:	
C.02		UNLATCHED, SINGLE ACTING, SINGLE DOOR	
DOOR CONSTRUCTION OPTIONS			
44mm Halspan Optima			
FRAME MATERIAL			
Steel			
LIPPING TYPES			
L30/1			
MEETING STILE JUNCTION			
N/A			
OVERPANEL JUNCTION			
N/A			
LEAF ENVELOPE			
HEIGHT	WIDTH		
2227mm	1270mm		
2455mm	1153mm		
FIRE TEST EVIDENCE			
RF01074			
INTUMESCENT SPECIFICATION			
HEAD	LEAF	1no 20 x 4mm thick intumescent seal, positioned centrally to the leaf thickness	
VERTICAL EDGES	LEAF	1no 20 x 4mm thick intumescent seal, positioned centrally to the leaf thickness	

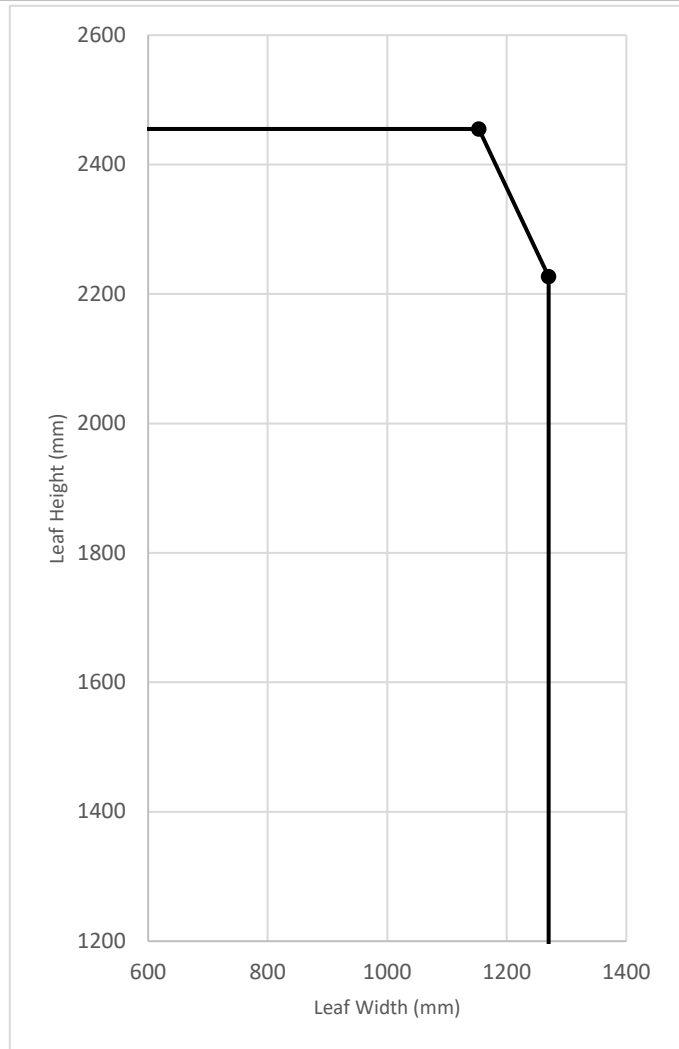

C.3 Approved Leaf Envelope C.03

FIGURE:		LEAF CONFIGURATION:	
C.03		LATCHED, SINGLE ACTING, DOUBLE DOOR	
DOOR CONSTRUCTION OPTIONS			
44mm Halspan Optima			
FRAME MATERIAL			
Steel			
LIPPING TYPES			
L30/1			
MEETING STILE JUNCTION			
Square			
OVERPANEL JUNCTION			
N/A			
LEAF ENVELOPE			
HEIGHT	WIDTH		
2227mm	920mm		
2455mm	834mm		
FIRE TEST EVIDENCE			
RF01073			
INTUMESCENT SPECIFICATION			
HEAD	LEAF	1no 20 x 4mm thick intumescent seal, positioned centrally to the leaf thickness	
VERTICAL EDGES	LEAF	1no 20 x 4mm thick intumescent seal, positioned centrally to the leaf thickness	
MEETING STILES	SQUARE	2no 10 x 4mm thick intumescent seals spaced 10mm apart, positioned centrally to the leaf thickness	

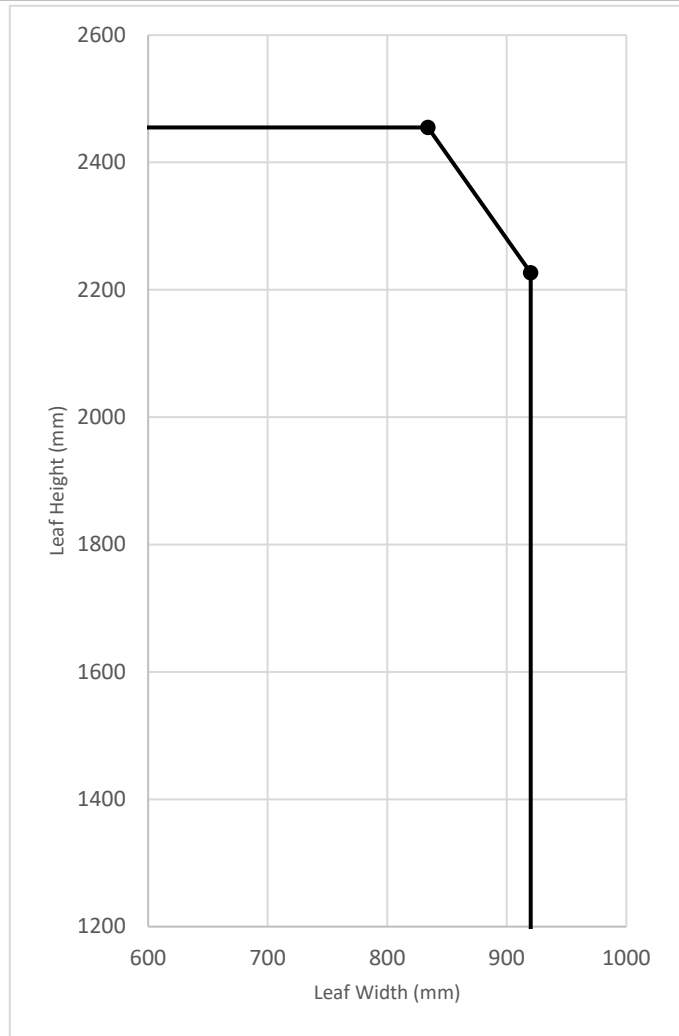

C.4 Approved Leaf Envelope C.04

FIGURE:		LEAF CONFIGURATION:	
D.04		UNLATCHED, SINGLE ACTING, DOUBLE DOOR	
DOOR CONSTRUCTION OPTIONS			
44mm Halspan Optima			
FRAME MATERIAL			
Steel			
LIPPING TYPES			
L30/1			
MEETING STILE JUNCTION			
Square			
OVERPANEL JUNCTION			
N/A			
LEAF ENVELOPE			
HEIGHT	WIDTH		
2227mm	920mm		
2455mm	834mm		
FIRE TEST EVIDENCE			
RF01073			
INTUMESCENT SPECIFICATION			
HEAD	LEAF	1no 20 x 4mm thick intumescent seal, positioned centrally to the leaf thickness	
VERTICAL EDGES	LEAF	1no 20 x 4mm thick intumescent seal, positioned centrally to the leaf thickness	
MEETING STILES	SQUARE	2no 10 x 4mm thick intumescent seals spaced 10mm apart, positioned centrally to the leaf thickness	

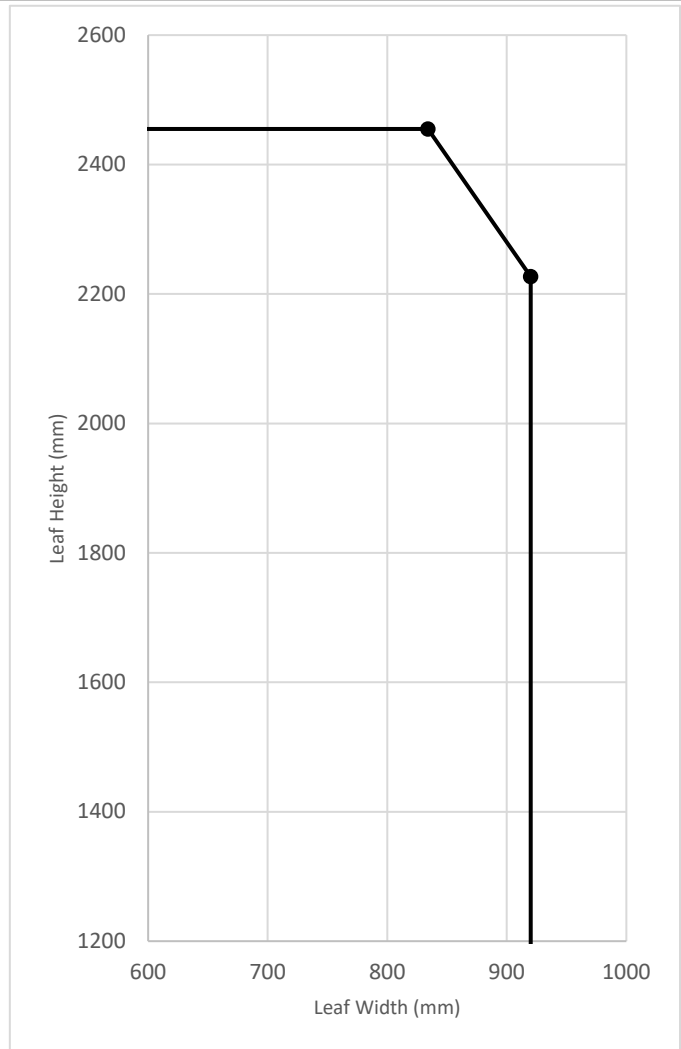

Appendix D – Approved Leaf Envelopes and Intumescent Seal Specifications for 44mm Thick Optima FD30 Doors in ALUMINIUM Frames

CONFIGURATION DESCRIPTION	CONFIGURATION CODE
Latched, Single Acting, Single Leaf / Optional transomed overpanel only	LSASD
Unlatched, Single Acting, Single Leaf / Optional transomed overpanel only	ULSASD
Double Acting, Single Leaf / Optional transomed overpanel only	DASD
Latched, Single Acting, Single Leaf with Flush Overpanel	LSASD+OP
Unlatched, Single Acting, Single Leaf with Flush Overpanel	ULSASD+OP
Double Acting, Single Leaf with Flush Overpanel	DASD+OP
Latched, Single Acting, Double Leaf / Optional transomed overpanel only	LSADD
Unlatched, Single Acting, Double Leaf / Optional transomed overpanel only	ULSADD
Double Acting, Double Leaf / Optional transomed overpanel only	DADD
Latched, Single Acting, Double Leaf with Flush Overpanel	LSADD+OP
Unlatched, Single Acting, Double Leaf with Flush Overpanel	ULSADD+OP
Double Acting, Double Leaf with Flush Overpanel	DADD+OP

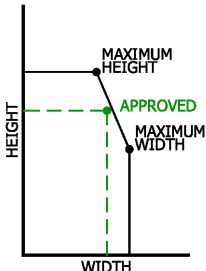
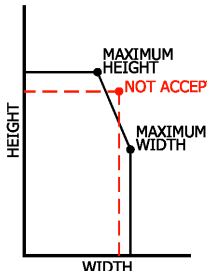
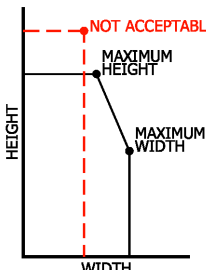
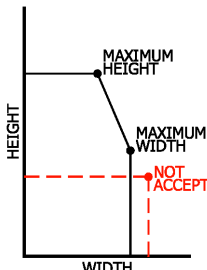

D.1 Approved Leaf Envelope D.01

FIGURE:		LEAF CONFIGURATION:	
D.01		LATCHED, SINGLE ACTING, SINGLE DOOR	
DOOR CONSTRUCTION OPTIONS			
44mm Halspan Optima			
FRAME MATERIAL			
Aluminium			
LIPPING TYPES			
L30/1			
MEETING STILE JUNCTION			
N/A			
OVERPANEL JUNCTION			
N/A			
LEAF ENVELOPE			
HEIGHT	WIDTH		
2817mm	963mm		
3105mm	874mm		
FIRE TEST EVIDENCE			
BTC 5547F			
INTUMESCENT SPECIFICATION			
HEAD	LEAF	1no 30 x 4mm thick intumescent seal, positioned centrally to the leaf thickness	
VERTICAL EDGES	LEAF	1no 20 x 4mm thick intumescent seal, positioned centrally to the leaf thickness	

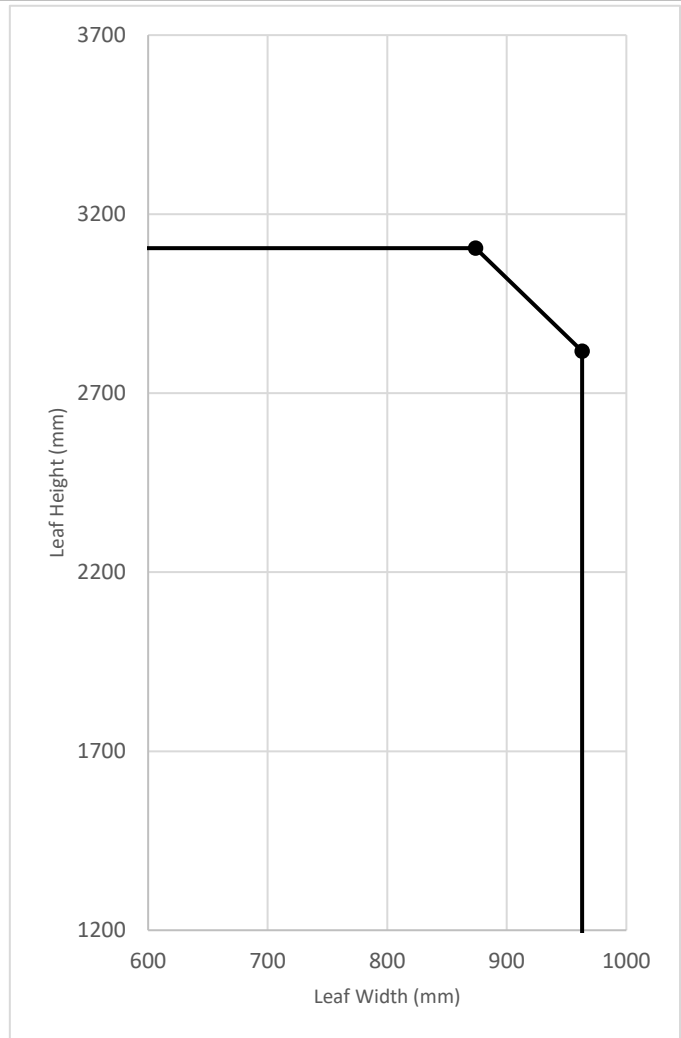

D.2 Approved Leaf Envelope D.02

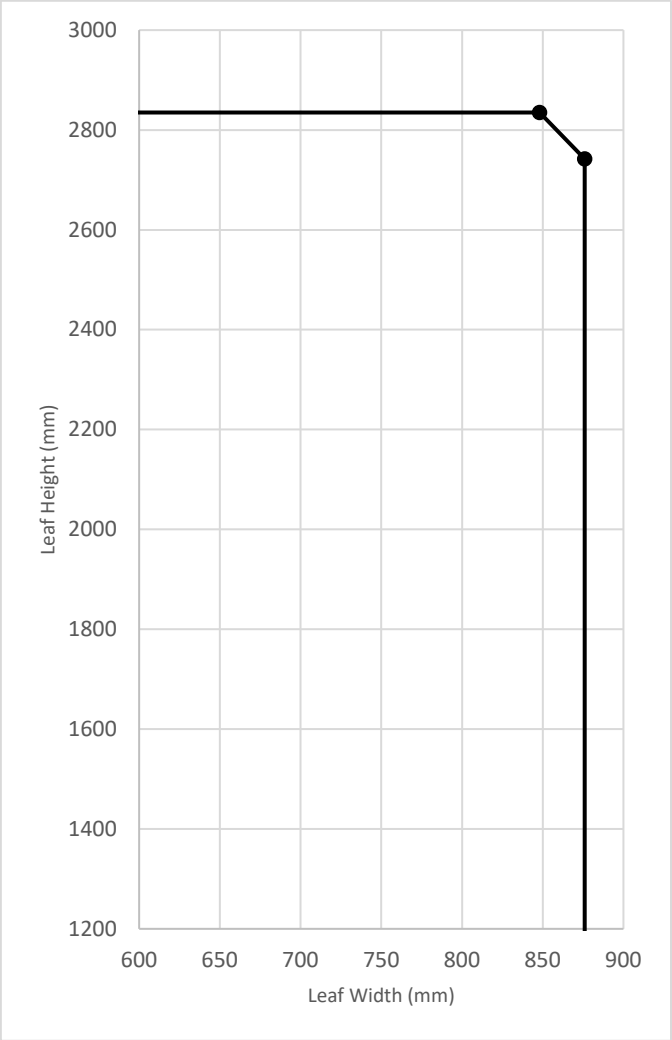
FIGURE:		LEAF CONFIGURATION:	
D.02		UNLATCHED, SINGLE ACTING, SINGLE DOOR	
DOOR CONSTRUCTION OPTIONS			
44mm Halspan Optima			
FRAME MATERIAL			
Aluminium			
LIPPING TYPES			
L30/1			
MEETING STILE JUNCTION			
N/A			
OVERPANEL JUNCTION			
N/A			
LEAF ENVELOPE			
HEIGHT	WIDTH		
2742mm	876mm		
2835mm	848mm		
FIRE TEST EVIDENCE			
WARRES 118289			
			
INTUMESCENT SPECIFICATION			
HEAD	LEAF	1no 30 x 4mm thick intumescent seal, positioned centrally to the leaf thickness	
VERTICAL EDGES	LEAF	1no 20 x 4mm thick intumescent seal, positioned centrally to the leaf thickness	

D.3 Approved Leaf Envelope D.03

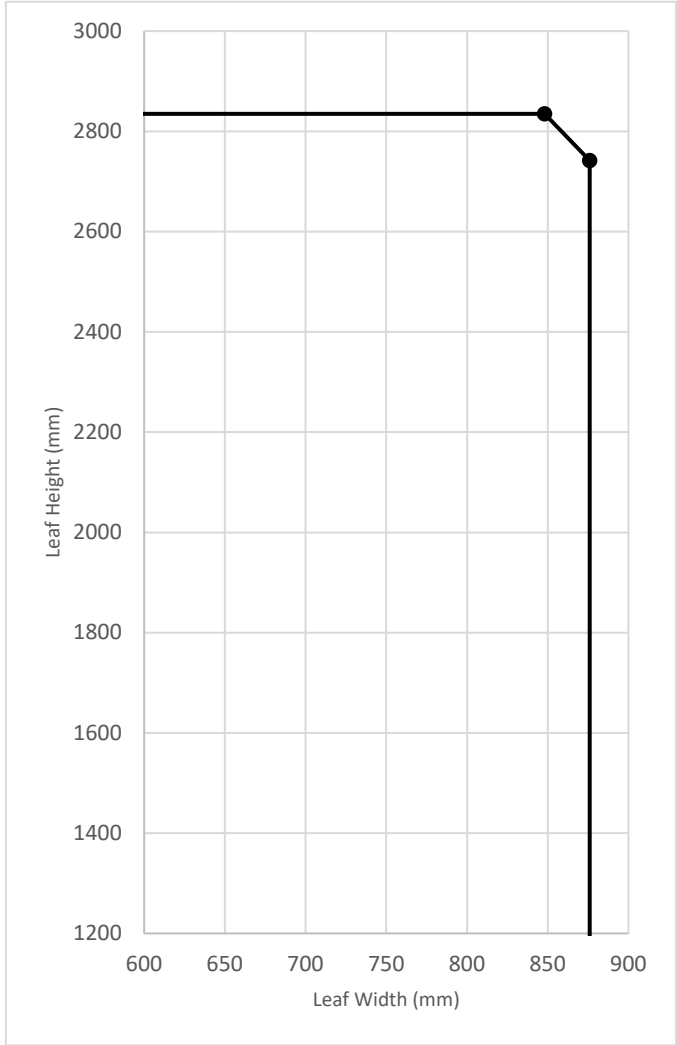
FIGURE:		LEAF CONFIGURATION:	
D.03		LATCHED, SINGLE ACTING, DOUBLE DOOR	
DOOR CONSTRUCTION OPTIONS			
44mm Halspan Optima			
FRAME MATERIAL			
Aluminium			
LIPPING TYPES			
L30/1			
MEETING STILE JUNCTION			
Square			
OVERPANEL JUNCTION			
N/A			
LEAF ENVELOPE			
HEIGHT	WIDTH		
2742mm	876mm		
2835mm	848mm		
FIRE TEST EVIDENCE			
WARRES 118289			
			
INTUMESCENT SPECIFICATION			
HEAD	LEAF	1no 30 x 4mm thick intumescent seal, positioned centrally to the leaf thickness	
VERTICAL EDGES	LEAF	1no 20 x 4mm thick intumescent seal, positioned centrally to the leaf thickness	
MEETING STILES	SQUARE	2no 10 x 4mm thick intumescent seals fitted centrally to one leaf and spaced 10mm apart.	

D.4 Approved Leaf Envelope D.04

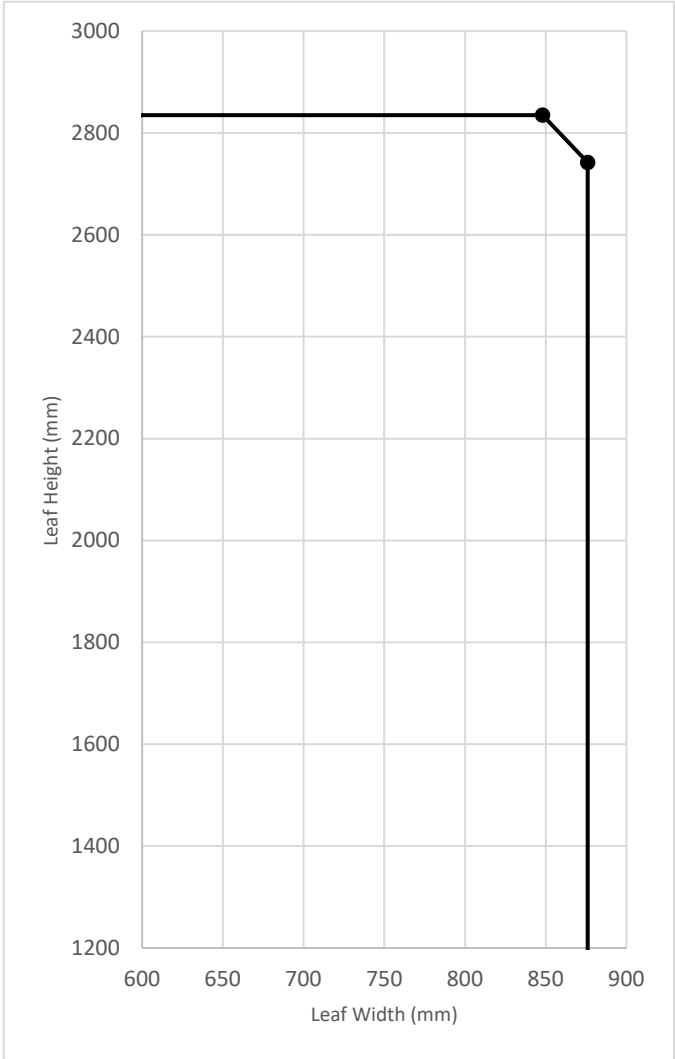
FIGURE:		LEAF CONFIGURATION:	
D.04		UNLATCHED, SINGLE ACTING, DOUBLE DOOR	
DOOR CONSTRUCTION OPTIONS			
44mm Halspan Optima			
FRAME MATERIAL			
Aluminium			
LIPPING TYPES			
L30/1			
MEETING STILE JUNCTION			
Square			
OVERPANEL JUNCTION			
N/A			
LEAF ENVELOPE			
HEIGHT	WIDTH		
2742mm	876mm		
2835mm	848mm		
FIRE TEST EVIDENCE			
WARRES 118289			
			
INTUMESCENT SPECIFICATION			
HEAD	LEAF	1no 30 x 4mm thick intumescent seal, positioned centrally to the leaf thickness	
VERTICAL EDGES	LEAF	1no 20 x 4mm thick intumescent seal, positioned centrally to the leaf thickness	
MEETING STILES	SQUARE	2no 10 x 4mm thick intumescent seals fitted centrally to one leaf and spaced 10mm apart.	

Appendix E – Approved Leaf Envelopes and Intumescent Seal Specifications for 44mm Thick BOND-UP FD30 Optima Doors in HARDWOOD Frames

CONFIGURATION DESCRIPTION	CONFIGURATION CODE
Latched, Single Acting, Single Leaf / Optional transomed overpanel only	LSASD
Unlatched, Single Acting, Single Leaf / Optional transomed overpanel only	ULSASD
Double Acting, Single Leaf / Optional transomed overpanel only	DASD
Latched, Single Acting, Single Leaf with Flush Overpanel	LSASD+OP
Unlatched, Single Acting, Single Leaf with Flush Overpanel	ULSASD+OP
Double Acting, Single Leaf with Flush Overpanel	DASD+OP
Latched, Single Acting, Double Leaf / Optional transomed overpanel only	LSADD
Unlatched, Single Acting, Double Leaf / Optional transomed overpanel only	ULSADD
Double Acting, Double Leaf / Optional transomed overpanel only	DADD
Latched, Single Acting, Double Leaf with Flush Overpanel	LSADD+OP
Unlatched, Single Acting, Double Leaf with Flush Overpanel	ULSADD+OP
Double Acting, Double Leaf with Flush Overpanel	DADD+OP

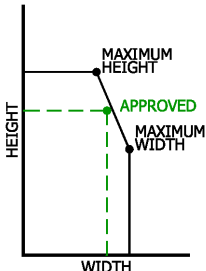
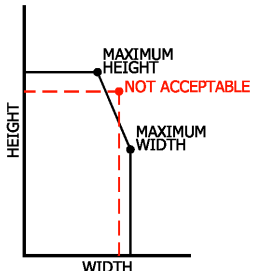
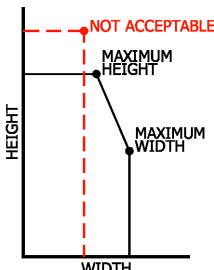
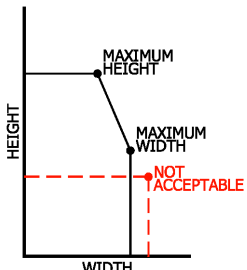
E.1 Approved Leaf Envelope E.01

FIGURE:		LEAF CONFIGURATION:	
E.01		LATCHED, SINGLE ACTING, SINGLE DOOR	
DOOR CONSTRUCTION OPTIONS			
44mm Halspan Optima Bond-Up			
FRAME MATERIAL			
Hardwood			
LIPPING TYPES			
L30/1, L30/8			
MEETING STILE JUNCTION			
N/A			
OVERPANEL JUNCTION			
N/A			
LEAF ENVELOPE			
HEIGHT		WIDTH	
2060mm		930mm	
FIRE TEST EVIDENCE			
RF03076			
			
INTUMESCENT SPECIFICATION			
HEAD	FRAME	1no 10 x 4mm thick intumescent seal, positioned centrally to the leaf thickness	
VERTICAL EDGES	FRAME	1no 10 x 4mm thick intumescent seal, positioned centrally to the leaf thickness at the hanging jamb	
		and 1no 25 x 4mm thick intumescent seal, positioned centrally to the leaf thickness at the closing jamb	

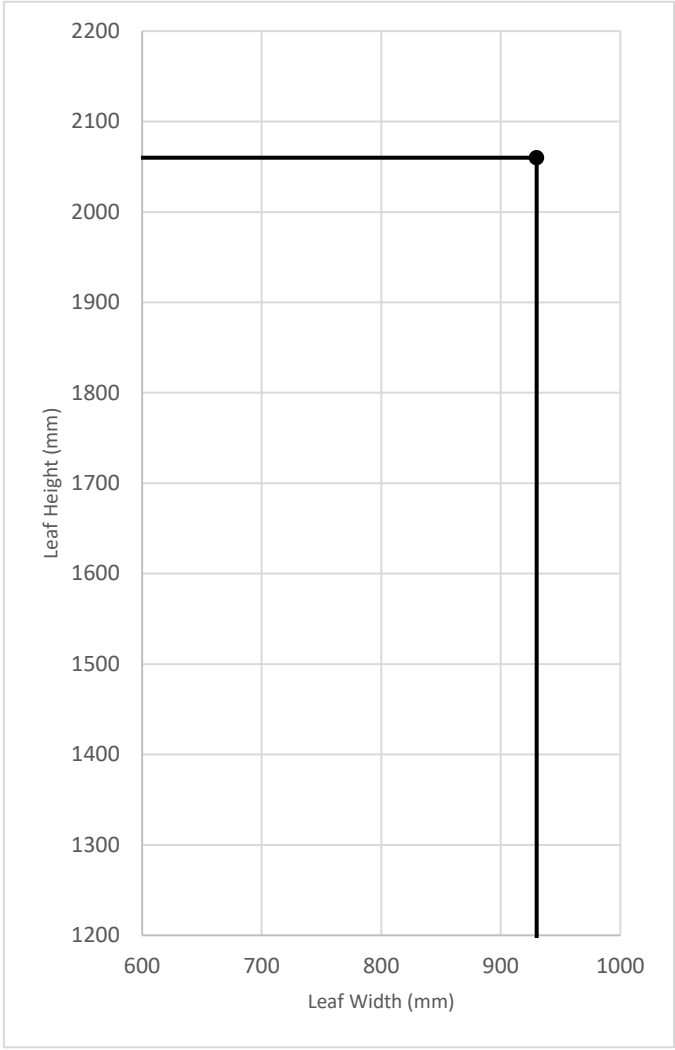
E.2 Approved Leaf Envelope E.02

FIGURE:		LEAF CONFIGURATION:	
E.02		UNLATCHED, SINGLE ACTING, SINGLE DOOR	
DOOR CONSTRUCTION OPTIONS			
44mm Halspan Optima Bond-Up			
FRAME MATERIAL			
Hardwood			
LIPPING TYPES			
L30/1, L30/8			
MEETING STILE JUNCTION			
N/A			
OVERPANEL JUNCTION			
N/A			
LEAF ENVELOPE			
HEIGHT		WIDTH	
2060mm		930mm	
FIRE TEST EVIDENCE			
RF03076			
			
INTUMESCENT SPECIFICATION			
HEAD	FRAME	1no 10 x 4mm thick intumescent seal, positioned centrally to the leaf thickness	
VERTICAL EDGES	FRAME	1no 10 x 4mm thick intumescent seal, positioned centrally to the leaf thickness at the hanging jamb and 1no 25 x 4mm thick intumescent seal, positioned centrally to the leaf thickness at the closing jamb	

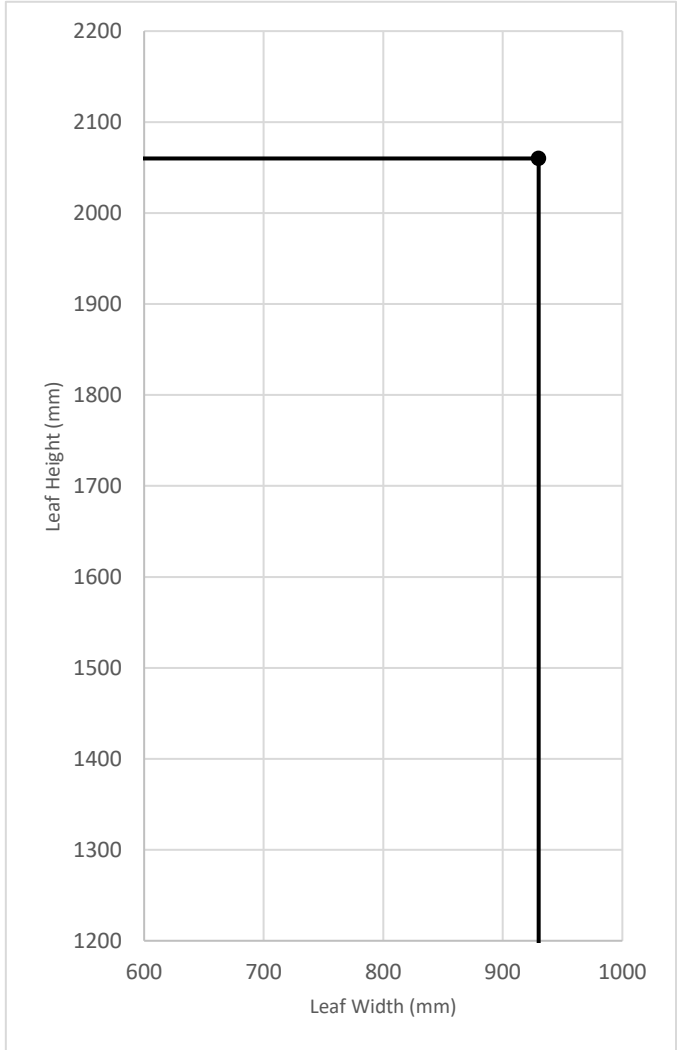
E.3 Approved Leaf Envelope E.03

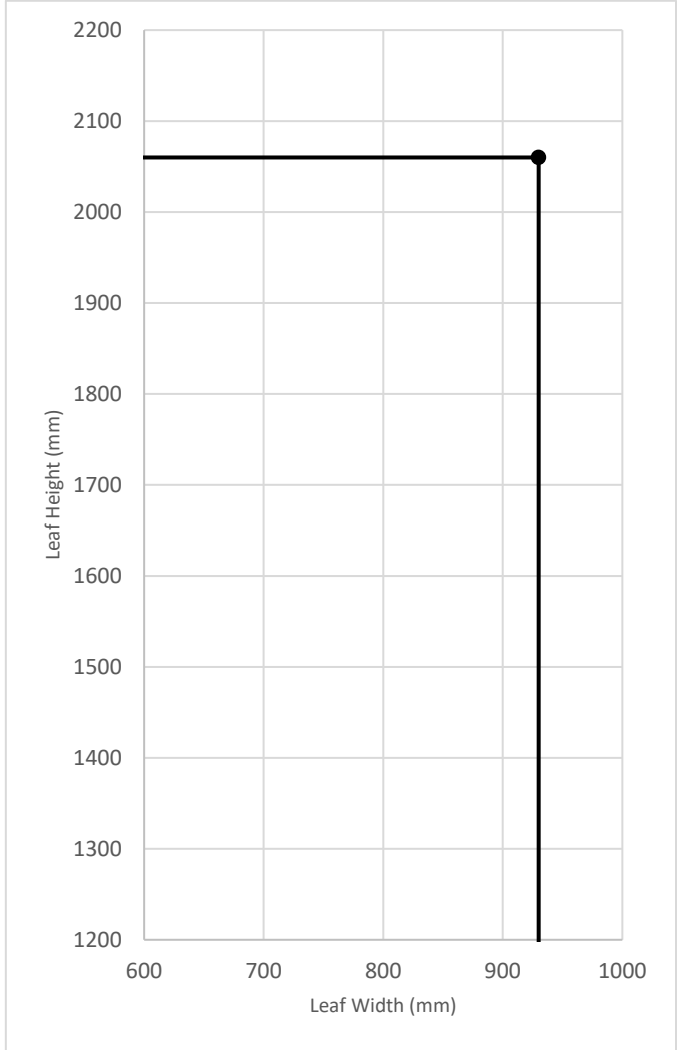
FIGURE:		LEAF CONFIGURATION:	
E.03		LATCHED, SINGLE ACTING, SINGLE DOOR, WITH TRANSOMED OVERPANEL	
DOOR CONSTRUCTION OPTIONS			
44mm Halspan Optima Bond-Up			
FRAME MATERIAL			
Hardwood			
LIPPING TYPES			
L30/1. L30/8			
MEETING STILE JUNCTION			
N/A			
OVERPANEL JUNCTION			
Transomed			
LEAF ENVELOPE			
HEIGHT		WIDTH	
2060mm		930mm	
FIRE TEST EVIDENCE			
RF03076			
			
INTUMESCENT SPECIFICATION			
HEAD	FRAME	1no 10 x 4mm thick intumescent seal, positioned centrally to the leaf thickness	
VERTICAL EDGES	FRAME	1no 10 x 4mm thick intumescent seal, positioned centrally to the leaf thickness at the hanging jamb and 1no 25 x 4mm thick intumescent seal, positioned centrally to the leaf thickness at the closing jamb	
TRANSOMED OVERPANEL	OVERPANEL EDGES	1no 10 x 4mm thick intumescent seal, positioned centrally to the overpanel thickness	

E.4 Approved Leaf Envelope E.04

FIGURE:		LEAF CONFIGURATION:	
E.04		UNLATCHED, SINGLE ACTING, SINGLE DOOR WITH TRANSOMED OVERPANEL	
DOOR CONSTRUCTION OPTIONS			
44mm Halspan Optima Bond-Up			
FRAME MATERIAL			
Hardwood			
LIPPING TYPES			
L30/1, L30/8			
MEETING STILE JUNCTION			
N/A			
OVERPANEL JUNCTION			
Transomed			
LEAF ENVELOPE			
HEIGHT		WIDTH	
2060mm		930mm	
FIRE TEST EVIDENCE			
RF03076			
			
INTUMESCENT SPECIFICATION			
HEAD	FRAME	1no 10 x 4mm thick intumescent seal, positioned centrally to the leaf thickness	
VERTICAL EDGES	FRAME	1no 10 x 4mm thick intumescent seal, positioned centrally to the leaf thickness at the hanging jamb and 1no 25 x 4mm thick intumescent seal, positioned centrally to the leaf thickness at the closing jamb	
TRANSOMED OVERPANEL	OVERPANEL EDGES	1no 10 x 4mm thick intumescent seal, positioned centrally to the overpanel thickness	

Appendix F – Approved Leaf Envelopes and Intumescent Seal Specifications for 44mm Thick PANELLED Optima FD30 Doors in HARDWOOD Frames

CONFIGURATION DESCRIPTION	CONFIGURATION CODE
Latched, Single Acting, Single Leaf / Optional transomed overpanel only	LSASD
Unlatched, Single Acting, Single Leaf / Optional transomed overpanel only	ULSASD
Double Acting, Single Leaf / Optional transomed overpanel only	DASD
Latched, Single Acting, Single Leaf with Flush Overpanel	LSASD+OP
Unlatched, Single Acting, Single Leaf with Flush Overpanel	ULSASD+OP
Double Acting, Single Leaf with Flush Overpanel	DASD+OP
Latched, Single Acting, Double Leaf / Optional transomed overpanel only	LSADD
Unlatched, Single Acting, Double Leaf / Optional transomed overpanel only	ULSADD
Double Acting, Double Leaf / Optional transomed overpanel only	DADD
Latched, Single Acting, Double Leaf with Flush Overpanel	LSADD+OP
Unlatched, Single Acting, Double Leaf with Flush Overpanel	ULSADD+OP
Double Acting, Double Leaf with Flush Overpanel	DADD+OP

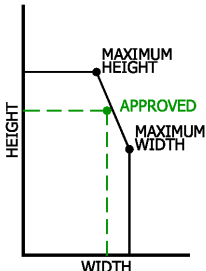
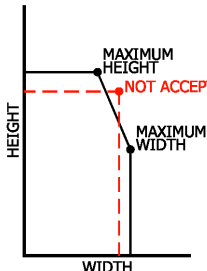
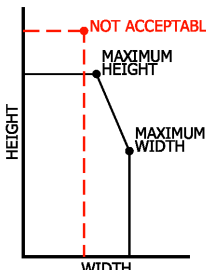
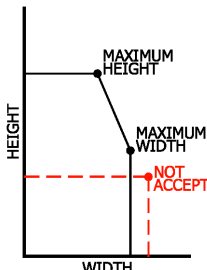
F.1 Approved Leaf Envelope F.01

FIGURE:		LEAF CONFIGURATION:	
F.01		LATCHED, SINGLE ACTING, SINGLE DOOR	
DOOR CONSTRUCTION OPTIONS			
44mm Halspan Optima Panelled			
FRAME MATERIAL			
Hardwood			
LIPPING TYPES			
L30/1			
MEETING STILE JUNCTION			
N/A			
OVERPANEL JUNCTION			
N/A			
LEAF ENVELOPE			
HEIGHT		WIDTH	
2126mm		1048mm	
2343mm		951mm	
FIRE TEST EVIDENCE			
RF05148			
			
INTUMESCENT SPECIFICATION			
HEAD	FRAME	1no 20 x 4mm thick intumescent seal, positioned centrally to the leaf thickness	
VERTICAL EDGES	FRAME	1no 20 x 4mm thick intumescent seal, positioned centrally to the leaf thickness	

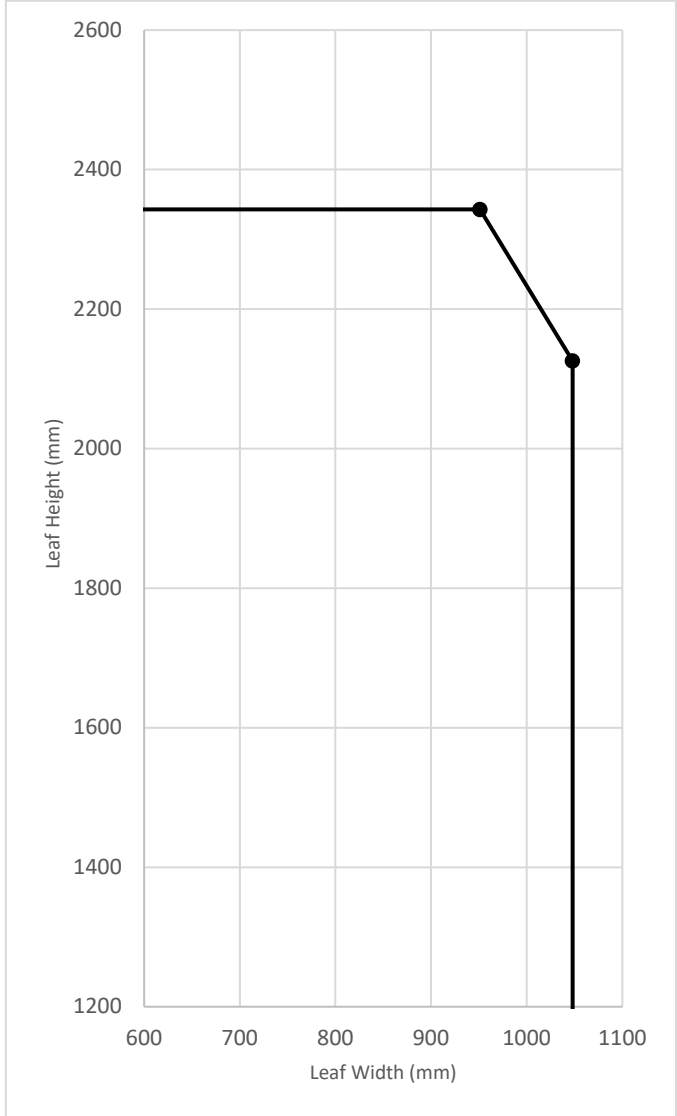
F.2 Approved Leaf Envelope F.02

FIGURE:		LEAF CONFIGURATION:	
F.02		UNLATCHED, SINGLE ACTING, SINGLE DOOR	
DOOR CONSTRUCTION OPTIONS			
44mm Halspan Optima Panelled			
FRAME MATERIAL			
Hardwood			
LIPPING TYPES			
L30/1			
MEETING STILE JUNCTION			
N/A			
OVERPANEL JUNCTION			
N/A			
LEAF ENVELOPE			
HEIGHT	WIDTH		
2126mm	1048mm		
2343mm	951mm		
FIRE TEST EVIDENCE			
RF05148			
			
INTUMESCENT SPECIFICATION			
HEAD	FRAME	1no 20 x 4mm thick intumescent seal, positioned centrally to the leaf thickness	
VERTICAL EDGES	FRAME	1no 20 x 4mm thick intumescent seal, positioned centrally to the leaf thickness	

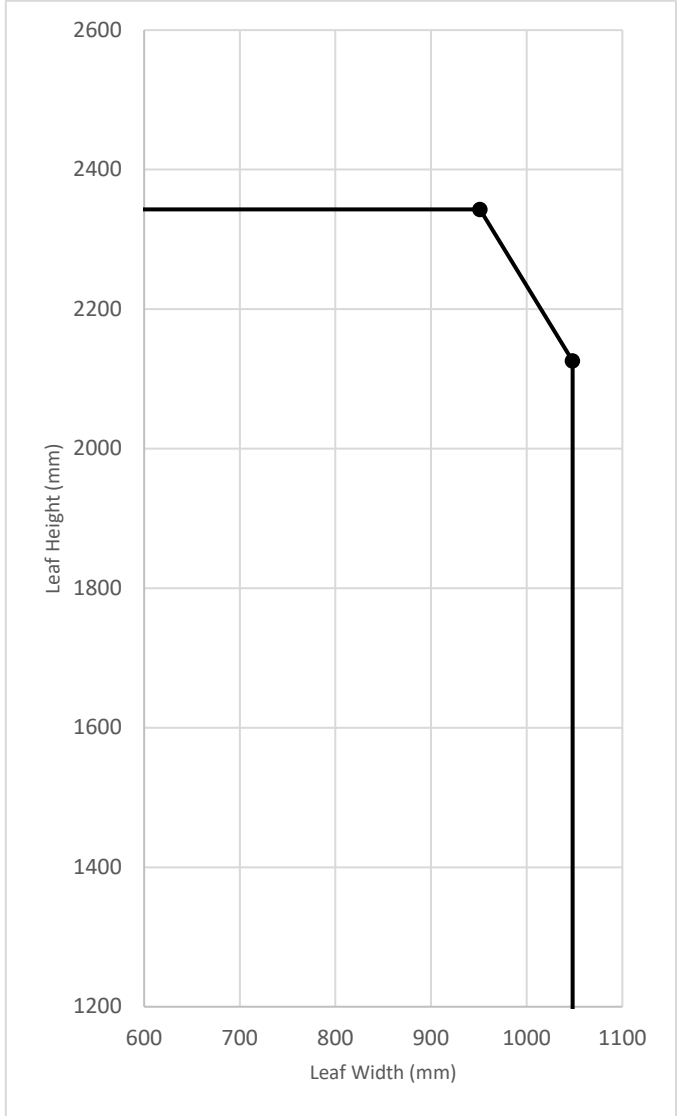
F.3 Approved Leaf Envelope F.03

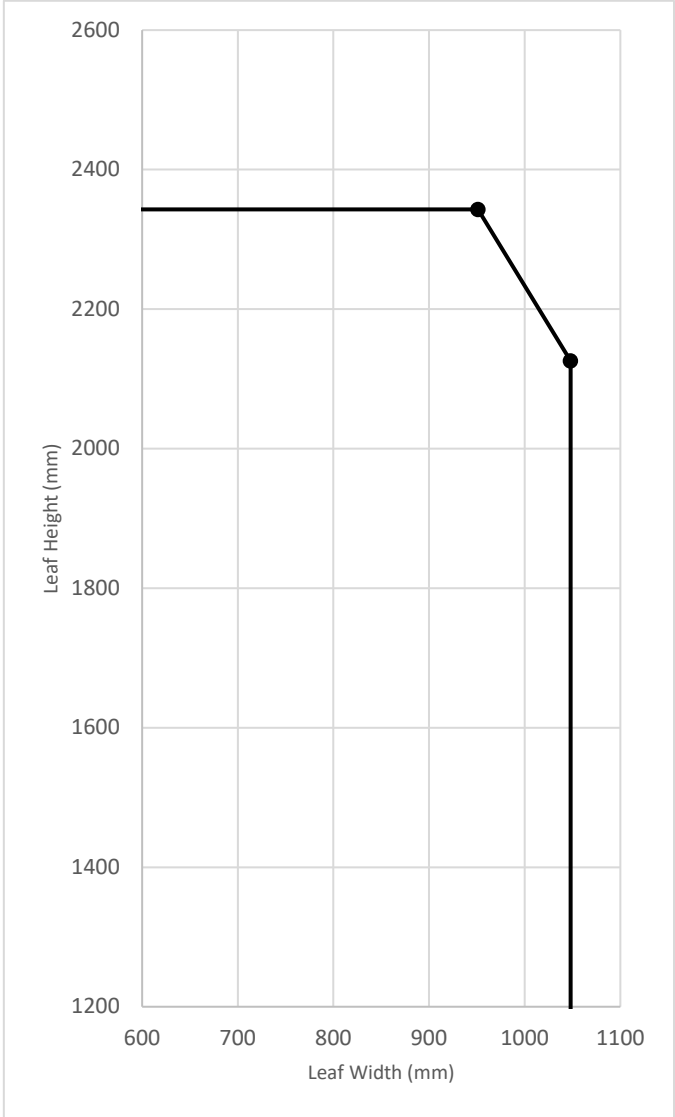
FIGURE:		LEAF CONFIGURATION:	
F.03		LATCHED, SINGLE ACTING, SINGLE DOOR, WITH TRANSOMED OVERPANEL	
DOOR CONSTRUCTION OPTIONS			
44mm Halspan Optima Panelled			
FRAME MATERIAL			
Hardwood			
LIPPING TYPES			
L30/1			
MEETING STILE JUNCTION			
N/A			
OVERPANEL JUNCTION			
Transomed			
LEAF ENVELOPE			
HEIGHT		WIDTH	
2126mm		1048mm	
2343mm		951mm	
FIRE TEST EVIDENCE			
RF05148			
			
INTUMESCENT SPECIFICATION			
HEAD	FRAME	1no 20 x 4mm thick intumescent seal, positioned centrally to the leaf thickness	
VERTICAL EDGES	FRAME	1no 20 x 4mm thick intumescent seal, positioned centrally to the leaf thickness	
TRANSOMED OVERPANEL	OVERPANEL EDGES	1no 20 x 4mm thick intumescent seal, positioned centrally to the overpanel thickness	

F.4 Approved Leaf Envelope F.04

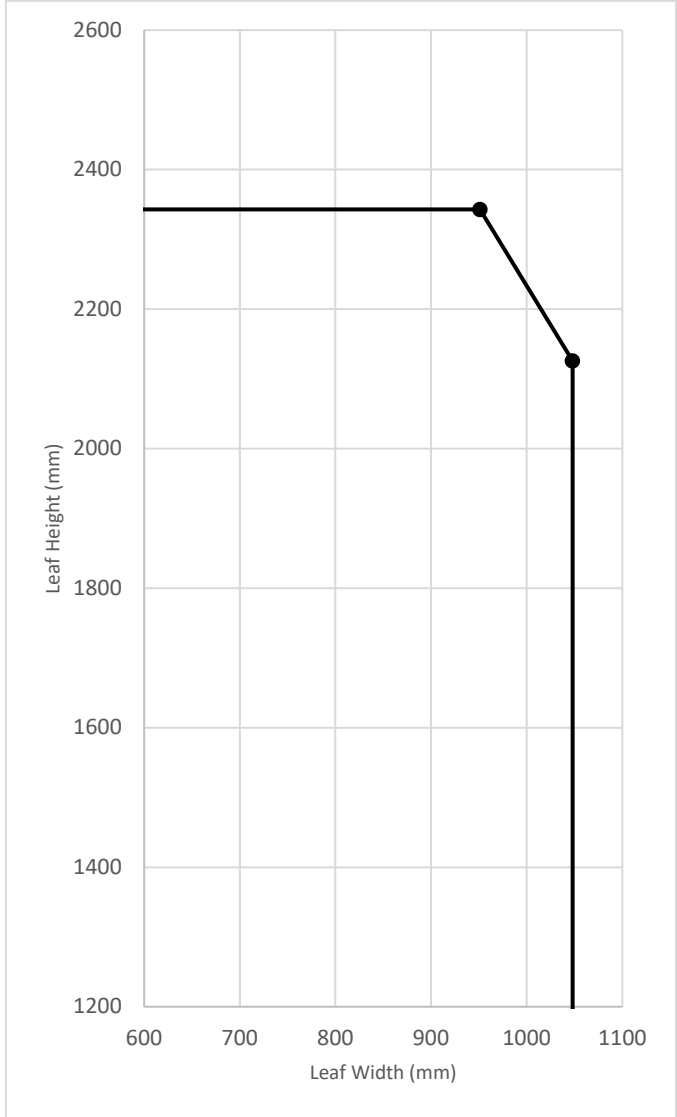
FIGURE:		LEAF CONFIGURATION:	
F.04		UNLATCHED, SINGLE ACTING, SINGLE DOOR, WITH TRANSOMED OVERPANEL	
DOOR CONSTRUCTION OPTIONS			
44mm Halspan Optima Panelled			
FRAME MATERIAL			
Hardwood			
LIPPING TYPES			
L30/1			
MEETING STILE JUNCTION			
N/A			
OVERPANEL JUNCTION			
Transomed			
LEAF ENVELOPE			
HEIGHT	WIDTH		
2126mm	1048mm		
2343mm	951mm		
FIRE TEST EVIDENCE			
RF05148			
			
INTUMESCENT SPECIFICATION			
HEAD	FRAME	1no 20 x 4mm thick intumescent seal, positioned centrally to the leaf thickness	
VERTICAL EDGES	FRAME	1no 20 x 4mm thick intumescent seal, positioned centrally to the leaf thickness	
TRANSOMED OVERPANEL	OVERPANEL EDGES	1no 20 x 4mm thick intumescent seal, positioned centrally to the overpanel thickness	

Appendix G – Approved Hardware Items

GENERAL REQUIREMENTS	
GENERAL INSTALLATION	<ul style="list-style-type: none"> All hardware items must be installed in accordance with the manufacturer's instructions, except where specific installation requirements or limitations have been detailed herein by KFS Mortices and holes must be cut/drilled tightly, such that there are the minimum possible to allow full function of the hardware when they are installed
APPROVED SCOPE	<p>Each section within this Appendix includes a table detailing the leaf configurations, maximum leaf size, door construction options, frame options and perimeter intumescent seal specifications which are approved with each item of hardware.</p> <p>Where these requirements differ across multiple hardware items and/or other items or details approved within this report, then the lowest common denominators must be selected for the proposed configuration (i.e. the smallest leaf size, the greatest intumescent specification etc)</p>
DOOR CLOSING DEVICES	<p>Except in those situations where Approved Document B Note or the project fire strategy permits the omission of self-closing devices, every hinged fire door (both leaves in double doors), including flat entrance doors and doors between a dwelling and an integral garage, must be fitted with a self-closing device.</p> <p>However, it is a requirement of this Field of Application Report, that when not in use, any Fire door <i>not</i> fitted with a self-closing device, must be closed fully into the frame reveal and retained shut by an engaged latch or lock.</p> <p>Door closing devices must also meeting all of the following requirements:</p> <ul style="list-style-type: none"> Meet the requirements of BS EN 1154:1997 Be adjusted so that they are capable of fully closing the door leaf, against any friction imposed by the latch, perimeter seals and/or an other items of hardware, from any position of opening. Where the door closing device is motor driven (if applicable), it must be capable of fulfilling the above requirements in the event of electrical power loss. <p><i>Note Approved Document B permits Fire doors to cupboards and Fire doors within flats or dwellings to be installed without self-closing devices</i></p>
HARDWARE MARGINS	<p>Unless specified otherwise herein, there must be:</p> <ul style="list-style-type: none"> A minimum 100mm margin between each hardware item A minimum 75mm margin between each item of hardware and any glazed apertures, feature grooves, recessed panels/areas and/or concealed cableways, if applicable The above dimensions must be measured edge-to-edge not centre-to-centre
HARDWARE QUANTITY	<p>Unless specifically noted otherwise herein, it is only permitted to fit 1no. of each approved hardware item per door leaf</p>
INTUMESCENT PROTECTION	<ul style="list-style-type: none"> The type/size/quantity of intumescent protection detailed, herein, may differ from that contained within the standard intumescent protection kit/s supplied by the hardware manufacturer/s. If this is the case, the intumescent protection specified by KFS, herein, takes precedence and must be used If no intumescent protection requirement is stipulated by KFS herein, then standard intumescent protection kits supplied by the hardware manufacturer may still be fitted

G.1 Single Axis Hinges

ELEMENT		SPECIFICATION/QUANTITY/DIMENSIONS					
HINGE TYPES		Fixed pin, washered butt, ball bearing butt, lift-off type or journal supported					
HINGE DIMENSIONS		Height	89-115mm	Width	30-36mm	Thickness	2.5-3.5mm
MATERIAL		Phosphor Bronze, Steel or Stainless Steel					
FIXINGS		Minimum 4no. 30mm long x 4mm diameter steel screws					
MINIMUM NUMBER		Leaves up to 2399mm high leaves			3no. hinges		
		Leaves over 2400mm high			4no. hinges		
		Two hinges may be used where the maximum spacing between the hinges does not exceed 800mm					
POSITIONS		Top		120 - 180mm down from the leaf head to the top of the hinge			
		Middle (Option 1)		Equi-spaced between the top and bottom hinges			
		Middle (Option 2)		2nd hinge positioned 200 – 250mm below the top hinge, with remaining intermediate hinges equi-spaced			
		Bottom		150 - 225mm up from the bottom of the leaf to the bottom of the hinge blade			
INTUMESCENT PROTECTION		<ul style="list-style-type: none"> Hinge blades must be bedded on 1mm thick MAP, Therm-A-Strip or graphite intumescent sheet When using steel door frames, the above intumescent material is required under the hinge blade in the door leaf only 					
ADDITIONAL REQUIREMENTS/NOTES		<ul style="list-style-type: none"> Rising butts, cranked butts and spring hinges (single or double action) are not approved under the scope of this Assessment Single axis hinges must have been successfully type tested for conformity to all the requirements of BS EN 1935: 2002 including the additional requirements for fire/smoke door use Single axis hinges must have a Door Mass Grade, as defined in BS EN 1935: 2002, which demonstrates the hinge is capable of supporting a door leaf weight, equal to, or greater than, that proposed. 					
DOOR CONFIGURATIONS				MAXIMUM LEAF SIZE		DOOR CONSTRUCTION	
LSASD	✓	LSADD	✓	Refer to relevant Figure in Appendix A to F, as applicable for the proposed door configuration		44mm Optima	✓
ULSASD	✓	ULSADD	✓			44mm Optima Bond-Up	✓
DASD	✗	DADD	✗			44mm Optima Panelled	✓
LSASD+OP	✓	LSADD+OP	✓				
ULSASD+OP	✓	ULSADD+OP	✓				
DASD+OP	✗	DADD+OP	✗				

PERIMETER INTUMESCENT SEAL SPECIFICATION	FRAME OPTIONS	
Refer to relevant Figure in Appendix A to F, as applicable for the proposed door configuration	Timber Frame	✓
	MDF Frame	✓
	Infilled Steel Frame	✓
	Aluminium Frame	✓

G.1.1 Single Axis Hinges – Projection Butt hinges

GENERAL REQUIREMENTS						
HINGE BLADE DIMENSIONS	Height	102mm	Width	42mm	Thickness	2.5 - 3.5mm
<ul style="list-style-type: none"> Hinge blade mortices must remain at 30-36mm deep This approval only applies to timber frame options Screw fixing holes in the hinge blades must be positioned in the same locations as those used in the single axis butt hinges described in Section G.1 (relative to the edge of each hinge blade) This approval only applies to projection butt hinges. Parliament hinges are not permitted under the scope of this Field of Application Report Aside from the above, projection butt hinges must meet all the requirements detailed in Section G.1 						

G.1.2 Single Axis Hinges – Security Butt Hinges

GENERAL REQUIREMENTS
<ul style="list-style-type: none"> Permitted to incorporate a single pin/bolt on either, one, or both blades, with a corresponding hole/s on the opposing blade Aside from the above, security butt hinges must meet all the requirements detailed in Section G.1

G.1.3 Single Axis Hinges – Conductor Butt Hinges

Conductor butt hinges are ***not*** permitted under the scope of this Field of Application Report

G.2 Concealed Hinges

ELEMENT	SPECIFICATION/QUANTITY/DIMENSIONS	
MINIMUM NUMBER	As detailed in the following sections for specific hinge types	
POSITIONS	Top	120 - 180mm down from the leaf head to the top of the hinge
	Middle (Option 1)	Equi-spaced between the top and bottom hinges
	Middle (Option 2)	2nd hinge positioned 200 – 250mm below the top hinge, with remaining intermediate hinges equi-spaced
	Bottom	120 - 225mm up from the bottom of the leaf to the bottom of the hinge blade
INTUMESCENT PROTECTION	Refer to Section G.2.1	
ADDITIONAL REQUIREMENTS/NOTES	The door frame hanging jamb must be a minimum 44mm thick	

DOOR CONFIGURATIONS	MAXIMUM LEAF SIZE	DOOR CONSTRUCTION	
See Hinge Specification Table below		44mm Optima	✓
		44mm Optima Bond-Up	✓
		44mm Optima Panelled	✓
PERIMETER INTUMESCENT SEAL SPECIFICATION		FRAME OPTIONS	
Refer to relevant Figure in Appendix A or F, as applicable for the proposed door configuration		Timber Frame	✓
		MDF Frame	✗
		Infilled Steel Frame	✗
		Aluminium Frame	✗

G.2.1 Tectus TE340 3D FR

ELEMENT	SPECIFICATION/QUANTITY/DIMENSIONS
HINGE BODY (FRAME)	160mm high x 28mm wide x 31mm deep
HINGE BODY (DOOR)	160mm high x 28mm wide x 33.5mm deep
FIXINGS	Steel screws - 40mm long x 5.2mm diameter
INTUMESCENT PROTECTION	Hinge bodies (leaf and frames) must include Roku Strips M130, self adhered along internal faces of each hinge blade, as tested in WF316349
ADDITIONAL REQUIREMENTS/NOTES	3no hinges required Maximum leaf dimensions permitted 1980mm high x 933mm wide 13mm high hardwood stop required Minimum frame thickness, 44mm thick
TEST REPORT	WF316349

G.2.2 Tectus TE640 3D A8 FR

ELEMENT	SPECIFICATION/QUANTITY/DIMENSIONS
HINGE BODY (FRAME)	240mm high x 32mm wide x 42mm deep
HINGE BODY (DOOR)	160mm high x 32mm wide x 44mm deep
FIXINGS	Steel screws - 40mm long x 5.2mm diameter
INTUMESCENT PROTECTION	Hinge bodies (leaf and frames) must include Roku Strips M130, self adhered along internal faces of each hinge blade, as tested in WF316349
ADDITIONAL REQUIREMENTS/NOTES	3no hinges required Maximum leaf dimensions permitted 1980mm high x 933mm wide 13mm high hardwood stop required Minimum frame thickness, 44mm thick
TEST REPORT	WF316349

G.3 Finger Safe Protection Hinges

This hardware item is ***not*** permitted under the scope of this Field of Application Report

G.4 Floor Spring and Accessories

GENERAL REQUIREMENTS/NOTES

- If the floor spring is to be used as the door closing device, it must be adjusted so that it is capable of fully closing the door leaf against any friction imposed by the latch (and smoke seals, if fitted), from any position of opening
- No removal of timber or intumescent strip (where fitted) is permitted at the hanging leaf edge, except for a 6-8mm diameter access hole for the top strap adjustment screw
- Frame heads must be a minimum of 44mm thick
- Transomed or flush overpanels are not permitted with floor springs

DOOR CONFIGURATIONS				MAXIMUM LEAF SIZE	DOOR CONSTRUCTION	
LSASD	×	LSADD	×	Refer to relevant Figure in Appendix A or F, as applicable for the proposed door configuration	44mm Optima	✓
ULSASD	×	ULSADD	×		44mm Optima Bond-Up	×
DASD	✓	DADD	✓		44mm Optima Panelled	×
LSASD+OP	×	LSADD+OP	×			
ULSASD+OP	×	ULSADD+OP	×			
DASD+OP	×	DADD+OP	×			

PERIMETER INTUMESCENT SEAL SPECIFICATION	FRAME OPTIONS	
Refer to relevant Figure in Appendix A or F, as applicable for the proposed door configuration	Timber Frame	✓
	MDF Frame	✗
	Infilled Steel Frame	✗
	Aluminium Frame	✗

G.4.1 Floor Spring/Accessories – Dorma BTS 75

ELEMENT	SPECIFICATION/QUANTITY/DIMENSIONS	
FLOOR SPRING MODEL/S	Dorma BTS 75V and BTS75R	
DIMENSIONS	285mm long x 82mm wide x 50mm deep	
POSITION	Recessed into the floor on the centre line of the leaf thickness	
MATERIAL	Aluminium (body) and Steel (cover plate, spindle and spring)	
TOP CENTRE MODEL/S	Dorma 8066	
DIMENSIONS	165mm long x 25mm wide x 42mm deep	
POSITION	Fitted on the centre line of the leaf thickness in the frame head	
MATERIAL	Steel	
TOP STRAP MODEL/S	Dorma 8066	
DIMENSIONS	122mm long x 29mm wide x 15mm deep	
POSITION	Fitted on the centre line of the leaf thickness in the top leaf edge	
MATERIAL	Steel	
BOTTOM STRAP MODEL/S	Dorma 7421	
DIMENSIONS	235mm long x 24mm wide x 20mm deep	
POSITION	Fitted on the centre line of the leaf thickness in the bottom leaf edge	
MATERIAL	Steel	
INTUMESCENT PROTECTION	Top Centre	Mortice to be lined with 2mm thick graphite intumescent sheet
	Top Strap	<ul style="list-style-type: none"> Mortice to be lined with, and face plate to be bedded on, 2mm thick graphite intumescent sheet 2mm thick graphite intumescent sheet covering the top plate
	Bottom Strap	Mortice lined with 2mm thick graphite intumescent sheet
ADDITIONAL REQUIREMENTS/NOTES	19mm thick hardwood lippings required at the leaf head/bottom	

G.4.2 Floor Spring/Accessories – Dorma BTS 80

ELEMENT	SPECIFICATION/QUANTITY/DIMENSIONS	
FLOOR SPRING MODEL/S	Dorma BTS 80	
DIMENSIONS	341mm long x 78mm wide x 60mm deep	
POSITION	Recessed into the floor on the centre line of the leaf thickness	
MATERIAL	Aluminium (body) and Steel (cover plate, spindle and spring)	
TOP CENTRE MODEL/S		
TOP CENTRE MODEL/S	Dorma 8066	
DIMENSIONS	165mm long x 25mm wide x 42mm deep	
POSITION	Fitted on the centre line of the leaf thickness in the frame head	
MATERIAL	Steel	
TOP STRAP MODEL/S		
TOP STRAP MODEL/S	Dorma 8066	
DIMENSIONS	122mm long x 29mm wide x 15mm deep	
POSITION	Fitted on the centre line of the leaf thickness in the top leaf edge	
MATERIAL	Steel	
BOTTOM STRAP MODEL/S		
BOTTOM STRAP MODEL/S	Dorma 7421	
DIMENSIONS	235mm long x 24mm wide x 20mm deep	
POSITION	Fitted on the centre line of the leaf thickness in the bottom leaf edge	
MATERIAL	Steel	
INTUMESCENT PROTECTION	Top Centre	Mortice to be lined with 2mm thick graphite intumescent sheet
	Top Strap	<ul style="list-style-type: none"> Mortice to be lined with, and face plate to be bedded on, 2mm thick graphite intumescent sheet 2mm thick graphite intumescent sheet covering the top plate
	Bottom Strap	Mortice lined with 2mm thick graphite intumescent sheet
ADDITIONAL REQUIREMENTS/NOTES	10mm thick hardwood (minimum 640kg/m ³) with a 38mm wide x 15mm deep tongue fitted at the top and bottom leaf edges	

G.5 Mechanical Single-Point Mortice Locks/Latches

ELEMENT	SPECIFICATION/QUANTITY/DIMENSIONS						
MAXIMUM FOREND DIMENSIONS	235mm high x 22mm wide x 3mm thick						
MAXIMUM STRIKE PLATE DIMENSIONS	180mm high x 40mm wide (excluding tongue)						
MAXIMUM BODY DIMENSIONS	165mm high x 82mm wide x 16mm thick						
MATERIAL	Steel based with no essential part of the lock/latch to comprise polymeric or other low melting point (<800°C) materials and must not contain any flammable materials						
POSITION	<ul style="list-style-type: none"> Centred at 1000mm (± 200mm) above the bottom of the door leaf in the closing leaf edge Fitted on the centreline of the leaf thickness 						
INTUMESCENT PROTECTION	Single and Double Leaf Door Assemblies						
	Forend Plate	Bedded on 1mm thick MAP intumescent sheet or Halspan Graphite					
	Strike Plate/Keep	Bedded on 1mm thick MAP intumescent sheet or Halspan Graphite					
	Lock Body	Wrapped in 1mm thick MAP intumescent sheet or Halspan Graphite					
ADDITIONAL REQUIREMENTS/NOTES	<ul style="list-style-type: none"> Morticed locks/latches must have been successfully type tested for conformity to all the requirements of BS EN 12209: 2016 including the additional requirements for fire/smoke door use Latch nibs are not permitted to be replaced with roller balls PVC 'dust boxes' may be used in conjunction with strike plates A minimum 75mm margin between each item of hardware and any glazed apertures, feature grooves, recessed panels, if applicable 						
DOOR CONFIGURATIONS				MAXIMUM LEAF SIZE	DOOR CONSTRUCTION		
LSASD	✓	LSADD	✓	Refer to relevant Figure in Appendix A to F, as applicable for the proposed door configuration	44mm Optima	✓	
ULSASD	✗	ULSADD	✗		44mm Optima Bond-Up	✓	
DASD	✗	DADD	✗		44mm Optima Panelled	✓	
LSASD+OP	✓	LSADD+OP	✓				
ULSASD+OP	✗	ULSADD+OP	✗				
DASD+OP	✗	DADD+OP	✗				
PERIMETER INTUMESCENT SEAL SPECIFICATION					FRAME OPTIONS		
Refer to relevant Figure in Appendix A to F, as applicable for the proposed door configuration					Timber Frame	✓	
					MDF Frame	✓	
					Infilled Steel Frame	✓	
					Aluminium Frame	✓	

G.5.1 Secondary Mortice Locks/Latches

The use of a second mortice lock, to the specifications, other than the lock dimensions and location, detailed in Section 5, is permitted herein; subject to the following limitations:

- Approved for use in timber frames only
- Approved for use in single acting, single door assemblies only
- The centre of any lock body must be a minimum of 320mm from the top of the leaf, or a minimum of 600mm from the bottom of the leaf.
- There shall be a minimum of 300mm between hardware items

ELEMENT	SPECIFICATION/QUANTITY/DIMENSIONS	
MAXIMUM FOREND DIMENSIONS	235mm high x 22mm wide x 3mm thick	
MAXIMUM STRIKE PLATE DIMENSIONS	155 high x 22mm wide (excluding tongue)	
MAXIMUM BODY DIMENSIONS	155mm high x 80mm wide x 16mm thick	
MATERIAL	Steel based with no essential part of the lock/latch to comprise polymeric or other low melting point (<800°C) materials and must not contain any flammable materials	
POSITION	<ul style="list-style-type: none"> • Centred at 1200mm (± 200mm) above the bottom of the door leaf in the closing leaf edge • Fitted on the centreline of the leaf thickness 	
INTUMESCENT PROTECTION	Single Leaf Door Assemblies	
	Forend Plate	Bedded on 1mm thick MAP intumescent sheet or Halspan Graphite
	Strike Plate/Keep	Bedded on 1mm thick MAP intumescent sheet or Halspan Graphite
Lock Body	Wrapped in 1mm thick MAP intumescent sheet or Halspan Graphite	
ADDITIONAL REQUIREMENTS/NOTES	<ul style="list-style-type: none"> • Morticed locks/latches must have been successfully type tested for conformity to all the requirements of BS EN 12209: 2016 including the additional requirements for fire/smoke door use • Latch nibs are not permitted to be replaced with roller balls unless all elements of the proposed door assembly are approved herein for use in unlatched configurations • PVC 'dust boxes' may be used in conjunction with strike plates 	

G.6 Morticed Roller Latches

Morticed roller latches are ***not*** permitted under the scope of this Field of Application Report when considered as point of restraint for a latched door. Door assemblies that have a specification completely approved for an unlatched configuration may utilise a roller latch as per the specification in Section C.5.

G.7 Multipoint Lock

DOOR CONFIGURATIONS				MAXIMUM LEAF SIZE	DOOR CONSTRUCTION	
LSASD	✓	LSADD	✗	Refer to relevant Figure in Appendix A or F, as applicable for the proposed door configuration	44mm Optima	✓
ULSASD	✗	ULSADD	✗		44mm Optima Bond-Up	✓
DASD	✗	DADD	✗		44mm Optima Panelled	✗
LSASD+OP	✓	LSADD+OP	✗			
ULSASD+OP	✗	ULSADD+OP	✗			
DASD+OP	✗	DADD+OP	✗			
PERIMETER INTUMESCENT SEAL SPECIFICATION					FRAME OPTIONS	
Refer to relevant Figure in Appendix A or F, as applicable for the proposed door configuration					Timber Frame	✓
					MDF Frame	✗
					Infilled Steel Frame	✗
					Aluminium Frame	✗

G.7.1 ERA 6945-80-85MA 3 Point Manual Lock

ELEMENT	SPECIFICATION/QUANTITY/DIMENSIONS	
MAXIMUM FOREND DIMENSIONS	1895mm high x 20mm wide x 2.5mm thick Backplate – 1838mm high x 11mm wide x 2mm thick	
MAXIMUM HOOK BOX DIMENSIONS UPPER/LOWER	155 high x 22mm wide (excluding tongue)	
CENTRE LATCH	Body – 220mm 57mm wide x 15mm thick Strike plate – 251mm x 45mm x 1.5mm thick (excluding tongue)	
MAXIMUM BODY DIMENSIONS	155mm high x 80mm wide x 16mm thick	
MATERIAL	Steel based with no essential part of the lock/latch to comprise polymeric or other low melting point (<800°C) materials and must not contain any flammable materials	
POSITION	<ul style="list-style-type: none"> Spindle positioned at 900mm (± 200mm) above the bottom of the door leaf in the closing leaf edge Fitted on the centreline of the leaf thickness 	
INTUMESCENT PROTECTION	Single Leaf Door Assemblies	
	Forend Plate	Bedded on 1mm thick MAP intumescent sheet or Halspan Graphite
	Strike Plate/Keep	Bedded on 1mm thick MAP intumescent sheet or Halspan Graphite
	Lock Body	Wrapped in 1mm thick MAP intumescent sheet or Halspan Graphite
ADDITIONAL REQUIREMENTS/NOTES	<ul style="list-style-type: none"> Must include a 25 x 4mm intumescent seal positioned in the closing edge jamb Morticed locks/latches must have been successfully type tested for conformity to all the requirements of BS EN 12209: 2016 including the additional requirements for fire/smoke door use Latch nibs are not permitted to be replaced with roller balls PVC 'dust boxes' may be used in conjunction with strike plates Not permitted with concealed clippings 	

G.8 Electronic Locks/Latches and Handlesets – Battery Operated

Battery operated electronic locks/latches and handlesets are ***not*** permitted under the scope of this Field of Application Report

G.9 Electronic Locks/Latches – Hardwired

Hardwired electronic locks/latches are ***not*** permitted under the scope of this Field of Application Report

G.10 Surface Mounted Mag Locks

Maglocks are ***not*** permitted under the scope of this Field of Application Report

G.11 Electric Strikes

Electric strikes are not permitted under the scope of this Field of Application Report

G.12 Concealed Cableways

G.12.1 Concealed Cableway in Door Leaf

Concealed cableways in the door leaf are not permitted under the scope of this Field of Application Report

G.13 Concealed Cable Loop

Concealed cable loops are not permitted under the scope of this Field of Application Report

G.14 Magnetic Door Contacts

Magnetic door contacts are not permitted under the scope of this Field of Application Report

G.15 Door Closing Devices

G.15.1 Surface Mounted Door Closers

GENERAL REQUIREMENTS/NOTES

- Surface mounted door closers must have been successfully fire tested for 30 minutes in accordance with BS476: Part22: 1987 or BS EN 1634-1:2014, when fitted to timber door leaves hung within timber frames or steel frames, as applicable. Surface mounted closers which have been assessed by KFS for use with FD30 timber door leaves hung without timber frames or steel frames, as applicable, may also be used.
- Surface mounted closer must not be installed directly above a glazed aperture containing non-insulating glass, unless they have been successfully fire tested when: (a) fitted on the unexposed face of an uninsulated steel door (b) fitted above an aperture which contained non-insulating glass in a fully glazed door. If no fire test evidence is available to demonstrate this, the surface mounted closer must be offset by a minimum of 100mm from the side of the glazed aperture

DOOR CONFIGURATIONS				MAXIMUM LEAF SIZE	DOOR CONSTRUCTION	
LSASD	✓	LSADD	✓	Refer to relevant Figure in Appendix A to F, as applicable for the proposed door configuration	44mm Optima	✓
ULSASD	✓	ULSADD	✓		44mm Optima Bond-Up	✓
DASD	✗	DADD	✗		44mm Optima Panelled	✓
LSASD+OP	✓	LSADD+OP	✓			
ULSASD+OP	✓	ULSADD+OP	✓			
DASD+OP	✗	DADD+OP	✗			
PERIMETER INTUMESCENT SEAL SPECIFICATION					FRAME OPTIONS	
Refer to relevant Figure in Appendix A to F, as applicable for the proposed door configuration					Timber Frame	✓
					MDF Frame	✓
					Infilled Steel Frame	✓
					Aluminium Frame	✓

G.15.2 Concealed Overhead Door Closers

GENERAL REQUIREMENTS/NOTES	
ELEMENT	SPECIFICATION/QUANTITY/DIMENSIONS
POSITION	<ul style="list-style-type: none"> The closer body is located in the leaf head and the closer slide arm channel is located in the frame head Must be located on the centreline of the leaf thickness
ADDITIONAL REQUIREMENTS/NOTES	<ul style="list-style-type: none"> Where concealed overhead door closers are installed in the 'top rail' between a glazed aperture and a door edge, the 'top rail' must be at least 200mm high Concealed overhead door closers are not permitted to be fitted in conjunction with other morticed hardware items in the leaf head e.g. morticed mag-locks Concealed closers are not permitted with flush or transomed overpanels Closers must be adjusted so that it is capable of fully closing the door leaf against any friction imposed by the latch (and smoke seals, if fitted), from any position of opening

G.15.2.1 Cairney C2300 Concealed Closer

ELEMENT	SPECIFICATION/QUANTITY/DIMENSIONS
SLIDE ARM MODELS	460mm long x 31mm wide x 20mm deep
CLOSER BODY	232mm long x 31mm wide x 20mm deep
INTUMESCENT PROTECTION	Slide Arm Channel Mortice Cairney Hardware Miltron 30 minute intumescent package
	Closer Body Mortice Cairney Hardware Miltron 30 minute intumescent package
	Top of Closer Body Cairney Hardware Miltron 30 minute intumescent package
ADDITIONAL REQUIREMENTS/NOTES	Fitted centrally in the leaf thickness positioned in the leaf head/frame interface

DOOR CONFIGURATIONS				MAXIMUM LEAF SIZE	DOOR CONSTRUCTION	
LSASD	✓	LSADD	✓	Refer to relevant Figure in Appendix A, as applicable for the proposed door configuration	44mm Optima	✓
ULSASD	✓	ULSADD	✓		44mm Optima Bond-Up	✗
DASD	✗	DADD	✗		44mm Optima Panelled	✗
LSASD+OP	✗	LSADD+OP	✗			
ULSASD+OP	✗	ULSADD+OP	✗			
DASD+OP	✗	DADD+OP	✗			

PERIMETER INTUMESCENT SEAL SPECIFICATION	FRAME OPTIONS	
Refer to relevant Figure in Appendix A, as applicable for the proposed door configuration	Timber Frame	✓
	MDF Frame	✗
	Infilled Steel Frame	✗
	Aluminium Frame	✗

G.15.3 Transom Door Closers

Transom door closers are not permitted under the scope of this Field of Application Report

G.15.4 Jamb Mounted Door Closers

Jamb mounted door closers are not permitted under the scope of this Field of Application Report

G.16 Door Operators

G.16.1 Geze Powerturn Door Operator

This hardware item is not permitted under the scope of this Field of Application Report

G.17 Flush Bolts

ELEMENT	SPECIFICATION/QUANTITY/DIMENSIONS	
MAXIMUM SIZE	Top Flush Bolt	250mm long x 20mm wide x 19mm deep
	Bottom Flush Bolt	250mm long x 20mm wide x 19mm deep
MATERIAL	Steel based with no essential part of the flush bolt to comprise polymeric or other low melting point (<800°C) materials and must not contain any flammable materials	
POSITION	<ul style="list-style-type: none"> Positioned at the top and bottom of the vertical meeting edge in the passive leaf only Must be located on the centre line of the leaf thickness 	
INTUMESCENT PROTECTION	All faces lined of flush bolt mortice must be lined with 1mm thick MAP intumescent sheet	
ADDITIONAL REQUIREMENTS/NOTES	<p>Flush bolts are not permitted in rebated meeting stiles or rebated leaf head interfaces</p> <p>Minimum 2no. 10 x 4mm intumescent seals positioned in the passive leaf edge, spaced 10mm apart</p> <p>For doorsets with an overpanel, a transomed must be utilised</p>	

DOOR CONFIGURATIONS				MAXIMUM LEAF SIZE	DOOR CONSTRUCTION	
LSASD	×	LSADD	✓	Refer to relevant Figure in Appendix A to F, as applicable for the proposed door configuration	44mm Optima	✓
ULSASD	×	ULSADD	×		44mm Optima Bond-Up	✓
DASD	×	DADD	×		44mm Optima Panelled	✓
LSASD+OP	×	LSADD+OP	✓			
ULSASD+OP	×	ULSADD+OP	×			
DASD+OP	×	DADD+OP	×			
PERIMETER INTUMESCENT SEAL SPECIFICATION					FRAME OPTIONS	
Refer to relevant Figure in Appendix A to F, as applicable for the proposed door configuration					Timber Frame	✓
					MDF Frame	×
					Infilled Steel Frame	✓
					Aluminium Frame	×

G.18 Surface Mounted Barrel Bolts

ELEMENT	SPECIFICATION/QUANTITY/DIMENSIONS
MAXIMUM DIMENSIONS	400mm long x 50mm wide
MATERIAL	Steel or aluminium
POSITION	Fixed to the top and bottom of the door leaf face
INTUMESCENT PROTECTION	None required
ADDITIONAL REQUIREMENTS/NOTES	<ul style="list-style-type: none"> • Must be located a minimum of 50mm away from the vertical leaf edge • Barrel bolts must be fixed using 25mm long steel screws which are threaded over the whole length of the screw • The use of surface mounted bolts without a mortice lock sits in the configuration of an unlatched door • For latched double door assemblies which include rebated meeting stiles or rebated leaf leaf/overpanel interface, surface mounted bolts must be utilised. Recessed flush bolts are not acceptable.

DOOR CONFIGURATIONS				MAXIMUM LEAF SIZE	DOOR CONSTRUCTION	
LSASD	✓	LSADD	✓	Refer to relevant Figure in Appendix A to F, as applicable for the proposed door configuration	44mm Optima	✓
ULSASD	✓	ULSADD	✓		44mm Optima Bond-Up	✓
DASD	✓	DADD	✓		44mm Optima Panelled	✓
LSASD+OP	✓	LSADD+OP	✓			
ULSASD+OP	✓	ULSADD+OP	✓			
DASD+OP	✗	DADD+OP	✗			
PERIMETER INTUMESCENT SEAL SPECIFICATION					FRAME OPTIONS	
Refer to relevant Figure in Appendix A to F, as applicable for the proposed door configuration					Timber Frame	✓
					MDF Frame	✗
					Infilled Steel Frame	✓
					Aluminium Frame	✗

G.19 Letter Plates

ELEMENT	SPECIFICATION
MODEL	Royde and Tucker LP08-44
MATERIAL	Aluminium and steel
ADDITIONAL PROTECTION	Integral to letter plate, which consists of a collar fitted to inside of plastic sleeve 38mm wide x 3mm thick
LOCATION	Centred at 800mm (\pm 200mm) Minimum 150mm from leaf edges and other apertures through the leaf
FIRE RESISTANCE TEST DATA	CFR1903071

DOOR CONFIGURATIONS				MAXIMUM LEAF SIZE	DOOR CONSTRUCTION	
LSASD	✓	LSADD	✓	Refer to relevant Figure in Appendix A to F, as applicable for the proposed door configuration	44mm Optima	✓
ULSASD	✓	ULSADD	✓		44mm Optima Bond-Up	✓
DASD	✗	DADD	✗		44mm Optima Panelled	✗
LSASD+OP	✓	LSADD+OP	✓			
ULSASD+OP	✓	ULSADD+OP	✓			
DASD+OP	✗	DADD+OP	✗			
PERIMETER INTUMESCENT SEAL SPECIFICATION				FRAME OPTIONS		
Refer to relevant Figure in Appendix A to F, as applicable for the proposed door configuration				Timber Frame		✓
				MDF Frame		✓
				Infilled Steel Frame		✓
				Aluminium Frame		✓

G.20 Push/Kick Plates

G.20.1 Push/Kick Plates – Screw Fixed

ELEMENT	SPECIFICATION/QUANTITY/DIMENSIONS	
MAXIMUM DIMENSIONS	Thickness	2mm
	Area	<ul style="list-style-type: none"> Maximum 1m² per leaf face but must comply with size restrictions detailed below Vertical and horizontal plates may be combined, provided maximum area stated above is not exceeded
	Vertical Plates	Maximum 200mm wide x full height of door leaf
	Horizontal Plates	Maximum 500mm high x full width of door leaf
FIXING	Mechanically fixed with maximum 25mm long screws on minimum 200mm centres	
MATERIAL	Steel or aluminium	
INTUMESCENT PROTECTION	None required	
ADDITIONAL REQUIREMENTS/NOTES	<ul style="list-style-type: none"> Plates must be cut short of door stops and glazing beads but may be located under handle rose/escutcheons Push/kick plates must be surface fixed only. These items must not be recessed 	

DOOR CONFIGURATIONS				MAXIMUM LEAF SIZE	DOOR CONSTRUCTION	
LSASD	✓	LSADD	✓	Refer to relevant Figure in Appendix A to F, as applicable for the proposed door configuration	44mm Optima	✓
ULSASD	✓	ULSADD	✓		44mm Optima Bond-Up	✓
DASD	✓	DADD	✓		44mm Optima Panelled	✓
LSASD+OP	✓	LSADD+OP	✓			
ULSASD+OP	✓	ULSADD+OP	✓			
DASD+OP	✓	DADD+OP	✓			
PERIMETER INTUMESCENT SEAL SPECIFICATION					FRAME OPTIONS	
Refer to relevant Figure in Appendix A to F, as applicable for the proposed door configuration					Timber Frame	✓
					MDF Frame	✓
					Infilled Steel Frame	✓
					Aluminium Frame	✓

G.20.2 Push/Kick Plates – Glued

ELEMENT	SPECIFICATION/QUANTITY/DIMENSIONS	
MAXIMUM DIMENSIONS	Thickness	2mm
	Area	No limitation
	Vertical Plates	No limitation
	Horizontal Plates	No limitation
FIXING	Adhered to the leaf using a thermally softening adhesive e.g. contact adhesive	
MATERIAL	Steel or aluminium	
INTUMESCENT PROTECTION	None required	
ADDITIONAL REQUIREMENTS/NOTES	<ul style="list-style-type: none"> Plates must be cut short of door stops and glazing beads but may be located under handle rose/escutcheons Push/kick plates must be surface fixed only. These items must not be recessed 	

DOOR CONFIGURATIONS				MAXIMUM LEAF SIZE	DOOR CONSTRUCTION	
LSASD	✓	LSADD	✓	Refer to relevant Figure in Appendix A to F, as applicable for the proposed door configuration	44mm Optima	✓
ULSASD	✓	ULSADD	✓		44mm Optima Bond-Up	✓
DASD	✓	DADD	✓		44mm Optima Panelled	✓
LSASD+OP	✓	LSADD+OP	✓			
ULSASD+OP	✓	ULSADD+OP	✓			
DASD+OP	✓	DADD+OP	✓			
PERIMETER INTUMESCENT SEAL SPECIFICATION					FRAME OPTIONS	
Refer to relevant Figure in Appendix A to F, as applicable for the proposed door configuration					Timber Frame	✓
					MDF Frame	✓
					Infilled Steel Frame	✓
					Aluminium Frame	✓

G.20.3 Push Plates with Return Edges

This hardware item is ***not*** permitted under the scope of this Field of Application Report

G.20.4 Kick Plates with Return Edges

This hardware item is ***not*** permitted under the scope of this Field of Application Report

G.21 Surface Mounted Pull Handles

ELEMENT	SPECIFICATION/QUANTITY/DIMENSIONS
MAXIMUM DIMENSIONS	Fixing points must be no greater than 800mm apart
MATERIAL	Brass, Steel or aluminium
INTUMESCENT PROTECTION	Bolt through fixings must be wrapped in 1mm thick graphite based intumescent sheet
ADDITIONAL REQUIREMENTS/NOTES	<ul style="list-style-type: none"> Pull handles that are fixed through the leaf shall use clearance holes as close fitting as possible to the bolt A margin of 50mm must be retained between the bolt positions and leaf edges, glazed apertures, feature grooves, recessed panels and all other hardware items Brass handles must have a melting point higher than 800°C

DOOR CONFIGURATIONS				MAXIMUM LEAF SIZE	DOOR CONSTRUCTION	
LSASD	✓	LSADD	✓	Refer to relevant Figure in Appendix A to F, as applicable for the proposed door configuration	44mm Optima	✓
ULSASD	✓	ULSADD	✓		44mm Optima Bond-Up	✓
DASD	✓	DADD	✓		44mm Optima Panelled	✓
LSASD+OP	✓	LSADD+OP	✓			
ULSASD+OP	✓	ULSADD+OP	✓			
DASD+OP	✗	DADD+OP	✗			
PERIMETER INTUMESCENT SEAL SPECIFICATION					FRAME OPTIONS	
Refer to relevant Figure in Appendix A to F, as applicable for the proposed door configuration					Timber Frame	✓
					MDF Frame	✓
					Infilled Steel Frame	✓
					Aluminium Frame	✓

G.22 Flush/Recessed Pull Handles

Flush/recessed pull handles are ***not*** permitted under the scope of this Field of Application Report

G.23 Door Viewer

G.23.1 Lorient LRJ3745

ELEMENT	SPECIFICATION/QUANTITY/DIMENSIONS
MAXIMUM DIMENSIONS	Barrel size 38mm diameter x 45mm Bevel size 50mm diameter x 16mm Oval face 44mm high x 61mm wide x 7mm deep Aperture size 41mm
MATERIAL	Plastic
INTUMESCENT PROTECTION	Lorient Polyproducts Graphite based intumescent with adhesive strip to one side fitted to barrel of viewer. 119mm long x 42mm wide x 2mm thick
ADDITIONAL REQUIREMENTS/NOTES	Positioned no higher than 1600mm FFL

DOOR CONFIGURATIONS				MAXIMUM LEAF SIZE	DOOR CONSTRUCTION	
LSASD	✓	LSADD	✓	Refer to relevant Figure in Appendix A to F, as applicable for the proposed door configuration	44mm Optima	✓
ULSASD	✓	ULSADD	✓		44mm Optima Bond-Up	✓
DASD	✓	DADD	✓		44mm Optima Panelled	✗
LSASD+OP	✓	LSADD+OP	✓			
ULSASD+OP	✓	ULSADD+OP	✓			
DASD+OP	✓	DADD+OP	✓			
PERIMETER INTUMESCENT SEAL SPECIFICATION					FRAME OPTIONS	
Refer to relevant Figure in Appendix A to F, as applicable for the proposed door configuration					Timber Frame	✓
					MDF Frame	✓
					Infilled Steel Frame	✓
					Aluminium Frame	✓

G.24 Door Selectors

ELEMENT	SPECIFICATION/QUANTITY/DIMENSIONS
MAXIMUM DIMENSIONS	No restrictions
MATERIAL	Steel or aluminium
POSITION	Surface mounted to the door leaf or frame
INTUMESCENT PROTECTION	None required
ADDITIONAL REQUIREMENTS/NOTES	<ul style="list-style-type: none"> The installation of the door selector must not involve the removal of any material from the door leaf or door frame The installation of door selectors which require the addition of a cableway through the door or frame are not approved

DOOR CONFIGURATIONS				MAXIMUM LEAF SIZE	DOOR CONSTRUCTION	
LSASD	×	LSADD	✓	Refer to relevant Figure in Appendix A to F, as applicable for the proposed door configuration	44mm Optima	✓
ULSASD	×	ULSADD	×		44mm Optima Bond-Up	✓
DASD	×	DADD	×		44mm Optima Panelled	✓
LSASD+OP	×	LSADD+OP	✓			
ULSASD+OP	×	ULSADD+OP	✓			
DASD+OP	×	DADD+OP	×			
PERIMETER INTUMESCENT SEAL SPECIFICATION					FRAME OPTIONS	
Refer to relevant Figure in Appendix A to F, as applicable for the proposed door configuration					Timber Frame	✓
					MDF Frame	✓
					Infilled Steel Frame	×
					Aluminium Frame	×

G.25 Acoustic and Smoke Seals

G.25.1 Drop Seals

GENERAL REQUIREMENTS/NOTES	
ELEMENT	SPECIFICATION/QUANTITY/DIMENSIONS
DROP SEAL MODELS	Option 1 SLS-DRP-Series (Halspan)
	Option 2 Lorient LAS8001 SI (Lorient Polyproducts Ltd)
	Option 3 RP8Si (Raven Products)
	Option 4 STS 422 (Sealed Tight Solutions)
	Option 5 STS 422GT (Sealed Tight Solutions)
	Option 6 NOR810S (Norseal)
	Option 7 NOR810 (Norseal)
MAXIMUM DIMENSIONS	35mm high x 14mm thick x full width of door leaf
POSITION	Fitted in the bottom leaf edge, located on the centreline of the leaf thickness
INTUMESCENT PROTECTION	None required
ADDITIONAL REQUIREMENTS/NOTES	<ul style="list-style-type: none"> It is not permitted to offset the drop seal in the leaf thickness to accommodate a lower flush bolt Not permitted with rebated meeting stiles

DOOR CONFIGURATIONS				MAXIMUM LEAF SIZE	DOOR CONSTRUCTION	
LSASD	✓	LSADD	✗	Refer to relevant Figure in Appendix A to F, as applicable for the proposed door configuration	44mm Optima	✓
ULSASD	✓	ULSADD	✓		44mm Optima Bond-Up	✓
DASD	✗	DADD	✗		44mm Optima Panelled	✓
LSASD+OP	✓	LSADD+OP	✗			
ULSASD+OP	✓	ULSADD+OP	✓			
DASD+OP	✗	DADD+OP	✗			
PERIMETER INTUMESCENT SEAL SPECIFICATION					FRAME OPTIONS	
Refer to relevant Figure in Appendix A to F, as applicable for the proposed door configuration					Timber Frame	✓
					MDF Frame	✗
					Infilled Steel Frame	✗
					Aluminium Frame	✗

G.25.2 Threshold Plates

Threshold plates are ***not*** permitted under the scope of this Field of Application Report

G.26 Steel Angle Door Stops

Steel angle door stops are not permitted under the scope of this Field of Application Report

G.27 Steel Security Astragals

This hardware item is not permitted under the scope of this Field of Application Report

G.28 Mechanical Door Stops – Retractable

Retractable mechanical door stops are not permitted under the scope of this Field of Application Report

G.29 Mechanical Door Stops – Hinged

Hinged mechanical door stops are not permitted under the scope of this Field of Application Report

G.30 Coat Hooks

ELEMENT	SPECIFICATION/QUANTITY/DIMENSIONS	
MATERIAL	Metal/alloy – must not contain, or be wrapped in, flammable materials	
FIXING	Option 1	Mechanically fixed with maximum 20mm long screws
	Option 2	Glued
POSITION	Surface mounted to one, or both faces, of the door leaf	
INTUMESCENT PROTECTION	None required	
ADDITIONAL REQUIREMENTS/NOTES	None	

DOOR CONFIGURATIONS				MAXIMUM LEAF SIZE	DOOR CONSTRUCTION	
LSASD	✓	LSADD	✓	Refer to relevant Figure in Appendix A to F, as applicable for the proposed door configuration	44mm Optima	✓
ULSASD	✓	ULSADD	✓		44mm Optima Bond-Up	✓
DASD	✗	DADD	✗		44mm Optima Panelled	✗
LSASD+OP	✓	LSADD+OP	✓			
ULSASD+OP	✓	ULSADD+OP	✓			
DASD+OP	✗	DADD+OP	✗			
PERIMETER INTUMESCENT SEAL SPECIFICATION					FRAME OPTIONS	
Refer to relevant Figure in Appendix A to F, as applicable for the proposed door configuration					Timber Frame	✓
					MDF Frame	✓
					Infilled Steel Frame	✓
					Aluminium Frame	✓

G.31 Door Numbers/Letters

ELEMENT	SPECIFICATION/QUANTITY/DIMENSIONS
MATERIAL	Metal/alloy – must not contain, or be wrapped in, flammable materials
FIXING	Option 1 Mechanically fixed with maximum 20mm long screws
	Option 2 Glued
POSITION	Surface mounted to one, or both faces, of the door leaf
INTUMESCENT PROTECTION	None required
ADDITIONAL REQUIREMENTS/NOTES	None

DOOR CONFIGURATIONS				MAXIMUM LEAF SIZE	DOOR CONSTRUCTION	
LSASD	✓	LSADD	✓	Refer to relevant Figure in Appendix A to F, as applicable for the proposed door configuration	44mm Optima	✓
ULSASD	✓	ULSADD	✓		44mm Optima Bond-Up	✓
DASD	✗	DADD	✗		44mm Optima Panelled	✗
LSASD+OP	✓	LSADD+OP	✓			
ULSASD+OP	✓	ULSADD+OP	✓			
DASD+OP	✗	DADD+OP	✗			
PERIMETER INTUMESCENT SEAL SPECIFICATION					FRAME OPTIONS	
Refer to relevant Figure in Appendix A to F, as applicable for the proposed door configuration					Timber Frame	✓
					MDF Frame	✓
					Infilled Steel Frame	✓
					Aluminium Frame	✓

G.32 Lever Handles

ELEMENT	SPECIFICATION/QUANTITY/DIMENSIONS	
MATERIAL	Spindle	Metal/alloy
	Handle Body	Metal/alloy – may be clad/wrapped in leather/timber
POSITION	Faced fixed to one, or both faces, of the door leaf to suit the lock/latch position	
INTUMESCENT PROTECTION	None required	
ADDITIONAL REQUIREMENTS/NOTES	<ul style="list-style-type: none"> This generic approval only applies to traditional ‘mechanical’ lever handles and does not apply to electro-mechanical handle sets Handles must not contain, or be wrapped in, flammable materials (other than leather/timber as stipulated above) 	

DOOR CONFIGURATIONS				MAXIMUM LEAF SIZE	DOOR CONSTRUCTION	
LSASD	✓	LSADD	✓	Refer to relevant Figure in Appendix A to H, as applicable for the proposed door configuration	44mm Optima	✓
ULSASD	✓	ULSADD	✓		44mm Optima Bond-Up	✓
DASD	✓	DADD	✓			
LSASD+OP	✓	LSADD+OP	✓			
ULSASD+OP	✓	ULSADD+OP	✓			
DASD+OP	✗	DADD+OP	✗			
PERIMETER INTUMESCENT SEAL SPECIFICATION					FRAME OPTIONS	
Refer to relevant Figure in Appendix A to H, as applicable for the proposed door configuration					Timber Frame	✓
					MDF Frame	✓
					Infilled Steel Frame	✓
					Aluminium Frame	✓

G.33 Fire Door Signage

G.33.1 Fire Door Discs

ELEMENT	SPECIFICATION/QUANTITY/DIMENSIONS
DIMENSIONS	100mm diameter x 2mm thick
FIXING	Option 1 Mechanically fixed with maximum 20mm long screws
	Option 2 Adhered to the leaf face using a thermally softening adhesive e.g. contact adhesive or PVA
POSITION	<ul style="list-style-type: none"> Fitted to one, or both, leaf faces Surface mounted
MATERIAL	Steel, aluminium, PVC, High Pressure Laminate or Acrylic
INTUMESCENT PROTECTION	None required
ADDITIONAL REQUIREMENTS/NOTES	None

DOOR CONFIGURATIONS				MAXIMUM LEAF SIZE	DOOR CONSTRUCTION	
LSASD	✓	LSADD	✓	Refer to relevant Figure in Appendix A to F, as applicable for the proposed door configuration	44mm Optima	✓
ULSASD	✓	ULSADD	✓		44mm Optima Bond-Up	✓
DASD	✓	DADD	✓		44mm Optima Panelled	✓
LSASD+OP	✓	LSADD+OP	✓			
ULSASD+OP	✓	ULSADD+OP	✓			
DASD+OP	✓	DADD+OP	✓			
PERIMETER INTUMESCENT SEAL SPECIFICATION					FRAME OPTIONS	
Refer to relevant Figure in Appendix A to F, as applicable for the proposed door configuration					Timber Frame	✓
					MDF Frame	✓
					Infilled Steel Frame	✓
					Aluminium Frame	✓

Appendix H – Summary of Fire Test Evidence

H.1 Primary Fire Test Data

TEST REPORT	TEST SPONSOR	TEST LAB	TEST DATE	CONFIGURATION	LEAF SIZE	TEST STANDARD	RESULT	ITEMS/DETAILS SUPPORTED BY TEST EVIDENCE
RF95042	Timber & Door Products	TRADA Technology Ltd	25.07.1995	ULSASD	2100mm x 874mm x 44mm	BS 476: Part 22: 1987	49 minutes	
RF95042	Timber & Door Products	TRADA Technology Ltd	25.07.1995	ULSADD	2100mm x 874/874mm x 44mm	BS 476: Part 22: 1987	35 minutes	
RF97091	Timber & Door Products	Chiltern International Fire	10.10.1997	ULSADD.OP	2130mm x 915/915mm x 45mm	BS 476: Part 22: 1987	39 minutes	<ul style="list-style-type: none"> 6mm Pilkington with Therm-A-Strip glazing system
BTC 5547F	Timber & Door Products	The Building Test Centre	20.04.1998	LSASD	2700mm x 838mm x 44mm	BS 476: Part 22: 1987	36 minutes	<ul style="list-style-type: none"> Door envelopes in aluminium frames
RF99036	Timber & Door Products	Chiltern International Fire	09.04.1999	ULSADD	2126mm x 915/915mm x 45mm	BS 476: Part 22: 1987	26 minutes	<ul style="list-style-type: none"> 6mm Pilkington with IGC8 Glazing channel
WARRES 111201	Halspan	Warringtonfire	06.01.2000	ULSADD	2042mm x 826/826mm x 44mm	BS 476: Part 22: 1987	42 minutes	
WARRES112248	Halspan	Warringtonfire	22.02.2000	ULSADD	2040mm x 726/412mm x 44mm	BS 476: Part 22: 1987	30 minutes	<ul style="list-style-type: none"> Reduced intumescent leaf envelopes 6mm Pilkington with Therm-A-Strip glazing system
RF00067	Halspan	Chiltern International Fire	03.08.2000	LSADD	2102mm x 877/809mm x 44mm	BS EN 1634-1: 2000	37 minutes	<ul style="list-style-type: none"> 6mm Pilkington with Therm-A-Strip glazing system

TEST REPORT	TEST SPONSOR	TEST LAB	TEST DATE	CONFIGURATION	LEAF SIZE	TEST STANDARD	RESULT	ITEMS/DETAILS SUPPORTED BY TEST EVIDENCE
RF00067	Halspan	Chiltern International Fire	03.08.2000	LSASD	2101mm x 826mm x 44mm	BS EN 1634-1: 2000	43 minutes	<ul style="list-style-type: none"> 6mm Pilkington with Therm-A-Strip glazing system
RF00068	Halspan	Chiltern International Fire	15.09.2000	ULSASD	2702mm x 915mm x 44mm	BS EN 1634-1: 2000	42 minutes	<ul style="list-style-type: none"> Concealed intumescent leaf envelopes
WARRES118409	Halspan	Warringtonfire	17.04.2001	ULSASD	2700mm x 836mm x 43mm	BS 476: Part 22: 1987	41 minutes	
WARRES 118289	Halspan	Warringtonfire	05.05.2001	ULSADD	2700mm x 835/835mm x 44mm	BS 476: Part 22: 1987	32 minutes	<ul style="list-style-type: none"> Leaf envelopes in aluminium frames
RF00165	Halspan	Chiltern International Fire	22.11.2000	ULSADD	2042mm x 826/826mm x 54mm	BS 476: Part 22: 1987	66 minutes	
RF01056	Halspan	Chiltern International Fire	09.07.2001	ULSASD	2040mm x 827mm x 44mm	BS 476: Part 22: 1987	39 minutes	<ul style="list-style-type: none"> Reduced intumescent specification leaf envelopes
RF01059	Halspan	Chiltern International Fire	16.07.2001	ULSASD	2040mm x 825mm x 44mm	BS 476: Part 22: 1987	39 minutes	<ul style="list-style-type: none"> Leaf envelopes
RF01073	Halspan	Chiltern International Fire	01.08.2001	ULSADD	2135mm x 800/300mm x 44mm	BS 476: Part 22: 1987	38 minutes	<ul style="list-style-type: none"> Leaf envelopes in steel frames
RF01074	Halspan	Chiltern International Fire	09.08.2001	ULSASD	2135mm x 1105mm x 44mm	BS 476: Part 22: 1987	58 minutes	<ul style="list-style-type: none"> Leaf envelopes in steel frames

TEST REPORT	TEST SPONSOR	TEST LAB	TEST DATE	CONFIGURATION	LEAF SIZE	TEST STANDARD	RESULT	ITEMS/DETAILS SUPPORTED BY TEST EVIDENCE
RF02098	Halspan	Chiltern International Fire	05.09.2002	ULSASD	2040mm x 936mm x 44mm	BS 476: Part 22: 1987	36 minutes	
WARRES 131998	Halspan	Warringtonfire	09.06.2003	ULSADD	2040mm x 920/200mm x 44mm	BS 476: Part 22: 1987	32 minutes	<ul style="list-style-type: none"> • 6mm Pilkington with Lorient Figure 1 glazing system • Leaf envelopes
RF03076	Halspan	Chiltern International Fire	14.08.2003	ULSASD	2060mm x 930mm x 44mm	BS 476: Part 22: 1987	30 minutes	<ul style="list-style-type: none"> • Bond-up door types
WARRES 135011	Halspan	Warringtonfire	28.10.2003	ULDADD	2040mm x 921/332mm x 44mm	BS 476: Part 22: 1987	36 minutes	<ul style="list-style-type: none"> • Radiused lipping • Double acting door assemblies
RF04021	Halspan	Chiltern International Fire	08.03.2004	ULSADD	2135mm x 825/501mm x 44mm	BS 476: Part 22: 1987	52 minutes	
RF04021	Halspan	Chiltern International Fire	08.03.2004	ULSASD	2135mm x 914mm x 44mm	BS 476: Part 22: 1987	49 minutes	
RF05080	Halspan	Chiltern International Fire	11.07.2005	ULSADD	2135mm x 915/915mm x 44mm	BS 476: Part 22: 1987	35 minutes	
RF05148	Halspan	Chiltern International Fire	09.03.2006	ULSASD	2038mm x 912mm x 44mm	BS 476: Part 22: 1987	38 minutes	<ul style="list-style-type: none"> • Panelled doors
RF05148	Halspan	Chiltern International Fire	09.03.2006	ULSASD	2040mm x 913mm x 44mm	BS 476: Part 22: 1987	36 minutes	<ul style="list-style-type: none"> • Panelled doors

TEST REPORT	TEST SPONSOR	TEST LAB	TEST DATE	CONFIGURATION	LEAF SIZE	TEST STANDARD	RESULT	ITEMS/DETAILS SUPPORTED BY TEST EVIDENCE
RF06068	Halspan	Chiltern International Fire	26.05.2006	ULSASD	2090mm x 926mm x 44mm	BS 476: Part 22: 1987	32 minutes	<ul style="list-style-type: none"> Leaf envelopes
RF08039	Halspan	Chiltern International Fire	28.03.2008	ULSADD	2055mm x 912/415mm x 46mm	BS 476: Part 22: 1987	50 minutes	<ul style="list-style-type: none"> Leaf envelopes
RF10111	Halspan	Chiltern International Fire	26.08.2010	ULSADD	2800mm x 928mm x 44mm	BS EN 1634-1: 2000	46 minutes	

H.2 Secondary Fire Test Data

TEST REPORT	TEST SPONSOR	TEST LAB	TEST DATE	CONFIGURATION	LEAF SIZE	TEST STANDARD	RESULT
BTC 5547F	Timber & Door Products	The Building Test Centre	20.04.1998	LSADD.OP	2000mm x 838/295mm x 44mm	BS 476: Part 22: 1987	13 minutes
RF99036	Timber & Door Products	Chiltern International Fire	09.04.1999	ULSADD	2126mm x 915/915mm x 45mm	BS 476: Part 22: 1987	26 minutes
RF02048	Sureglaze	Chiltern International Fire	10.05.2002	ULSADD	2040mm x 827/300mm x 44mm	BS 476: Part 22: 1987	35 minutes
RF02048	Sureglaze	Chiltern International Fire	10.05.2002	ULSADD	2040mm x 830/295mm x 44mm	BS 476: Part 22: 1987	41 minutes
WARRES 131998	Halspan	Warringtonfire	09.06.2003	ULSADD	2040mm x 926/200mm x 44mm	BS 476: Part 22: 1987	27 minutes
RF05026	Halspan	Chiltern International Fire	22.03.2005	LSADD	2110mm x 910/910mm x 44mm	BS EN 1634-1: 2000	29 minutes
RF05028	Halspan	Chiltern International Fire	10.03.2005	ULSADD	2030mm x 915/915mm x 44mm	BS 476: Part 22: 1987	25 minutes
RF06068	Halspan	Chiltern International Fire	26.05.2006	ULSASD	2040mm x 926mm x 44mm	BS 476: Part 22: 1987	19 minutes